

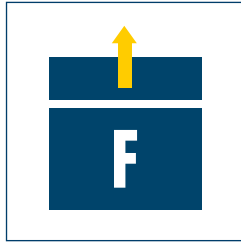

Useful stroke
up to 2,800 mm

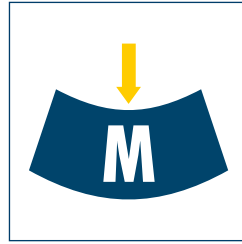

Driving force
up to 750 N



Deflection
0.1 mm .. 1 mm

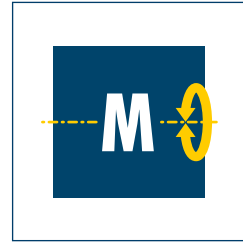

Moment load
up to 550 Nm

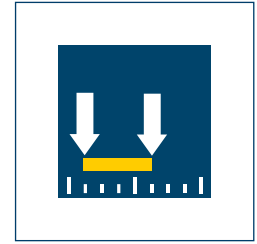

Repeat accuracy
0.01 mm

Module design

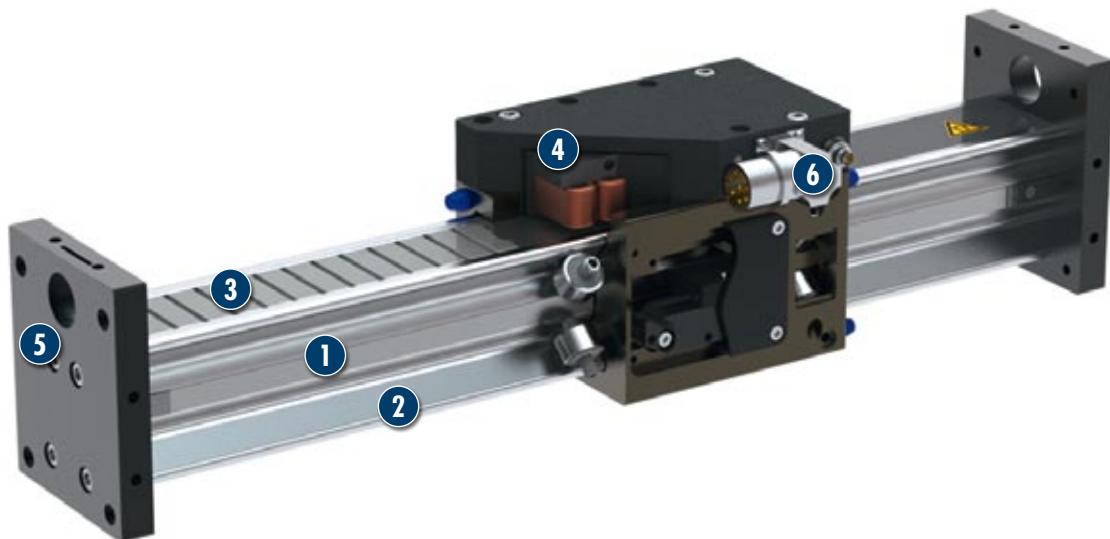

- 1** **Elongated X-shaped aluminum press-drawn section**
with high planar moments of inertia for maximum moment and shearing force load
- 2** **High precision, hardened and ground steel guide rails**
for optimum guidance properties and speeds
- 3** **Integrated secondary parts**
with high power magnets
- 4** **Compact primary part slide**
with mounting surfaces, rollers adjusted without play and integrated measuring system
- 5** **End plates**
for mounting sensors and shock absorbers
- 6** **Motor plug**

Linear axis with direct drive

and roller guide

Area of application

The self-supporting standard axis profile is designed for a huge range of applications.

It can be used as a gantry axis system with free moving slide or as a boom system in which the slide is fixed in place.

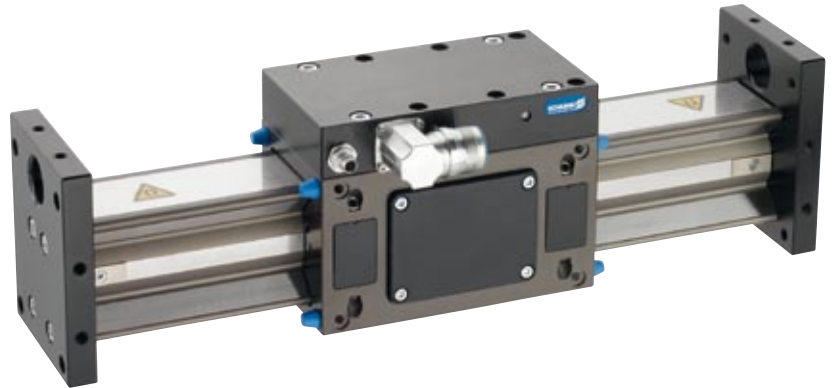

General information about the series

Drive

3-phase, electronically commutated AC synchronous linear motor.
Primary part 3-phase copper coil body, secondary part iron mount with permanent magnets and dirt cover.

Stroke measuring system

Non-contact magnetic measuring system with integrated analog signal output, 1 Vss (insensitive to contamination)

Profile guide

X-shaped aluminum press-drawn section with ground steel guide strips

Standard guided slide

Roller-guided slide adjustable with no play using cam, primary part and measuring system reading head directly integrated.

Attachments can be mounted and secured using thread and centering sleeves on three side surfaces.

Operating temperature

From 10 °C to 40 °C

Options

- Pneumatic brake to relieve load on linear motor, e.g. under influence of axial forces in target position or to secure waste for vertical axes in case of power failure or emergency stop.
- Second independent motor slide on a shared profile guide and with a linear measuring system.
Collision protection in case of programming errors is provided by corresponding limit switches.
- Second passive guided slide for long attachments (free moving)
- Wipers for removing deposits on the guideways.
- Absolute stroke measuring system and optical stroke measuring systems for applications with very high accuracy

Accessories

- Control units from Bosch Rexroth and Siemens (other manufacturers on request)
- Limit switching using either mechanical precision switches or inductive sensors; referencing using inductive sensors
- Hydraulic shock absorbers on the profile end heads to prevent inelastic collisions
- Cable track, pre-assembled and mounted on drive
- Adapter plates, bellow cover and stainless steel guide on request

Warranty

24 months

① Refer to ambient conditions on our introductory pages

For production reasons, the colors may vary from those shown in the catalog.



Load data

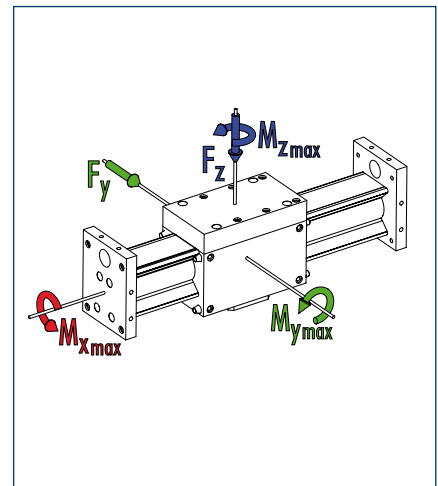

	MLD N	MLD NL	MLD NG
M_x max. [Nm]	140	140	140
M_y max. [Nm]	200	400	400
M_z max. [Nm]	200	400	550

Technical data

Designation		MLD 100N	MLD 200NL	MLD 300NG
Max. driving force (*)	[N]	250	500	750
Rated force (**)	[N]	88	154	224
Max. speed	[m/s]	4	4	4
Max. acceleration	[m/s ²]	40	40	40
Max. useful load (horizontal)	[kg]	15	25	35
Max. stroke	[mm]	2800	2700	2600
Repeat accuracy (***)	[mm]	0.01	0.01	0.01
Measuring system resolution (controller-dependent)	[µm]	0.5	0.5	0.5
Max. current	(A_{eff})	8.1	16.2	24.3
Max. continuous current at standstill	(A_{eff})	2.1	3.8	5.6
Max. ambient temperature	[°C]	40	40	40
Max. surface temperature	[°C]	70	70	70
Weight of guided slide inc. motor	[kg]	3.0	4.8	6.8
Weight of end plates	[kg]	0.75	0.75	0.75
Profile / 100mm stroke	[kg]	0.62	0.62	0.62

(*) Depending on controller type used

(**) Depending on installation situation (heat dissipation)

(***) The specified repeat accuracies are only applicable at constant ambient temperatures.

① The specified repeat accuracy applies at constant ambient temperatures.

Some of the specified forces can vary considerably when using different control units and with increasing travel speeds

Main views

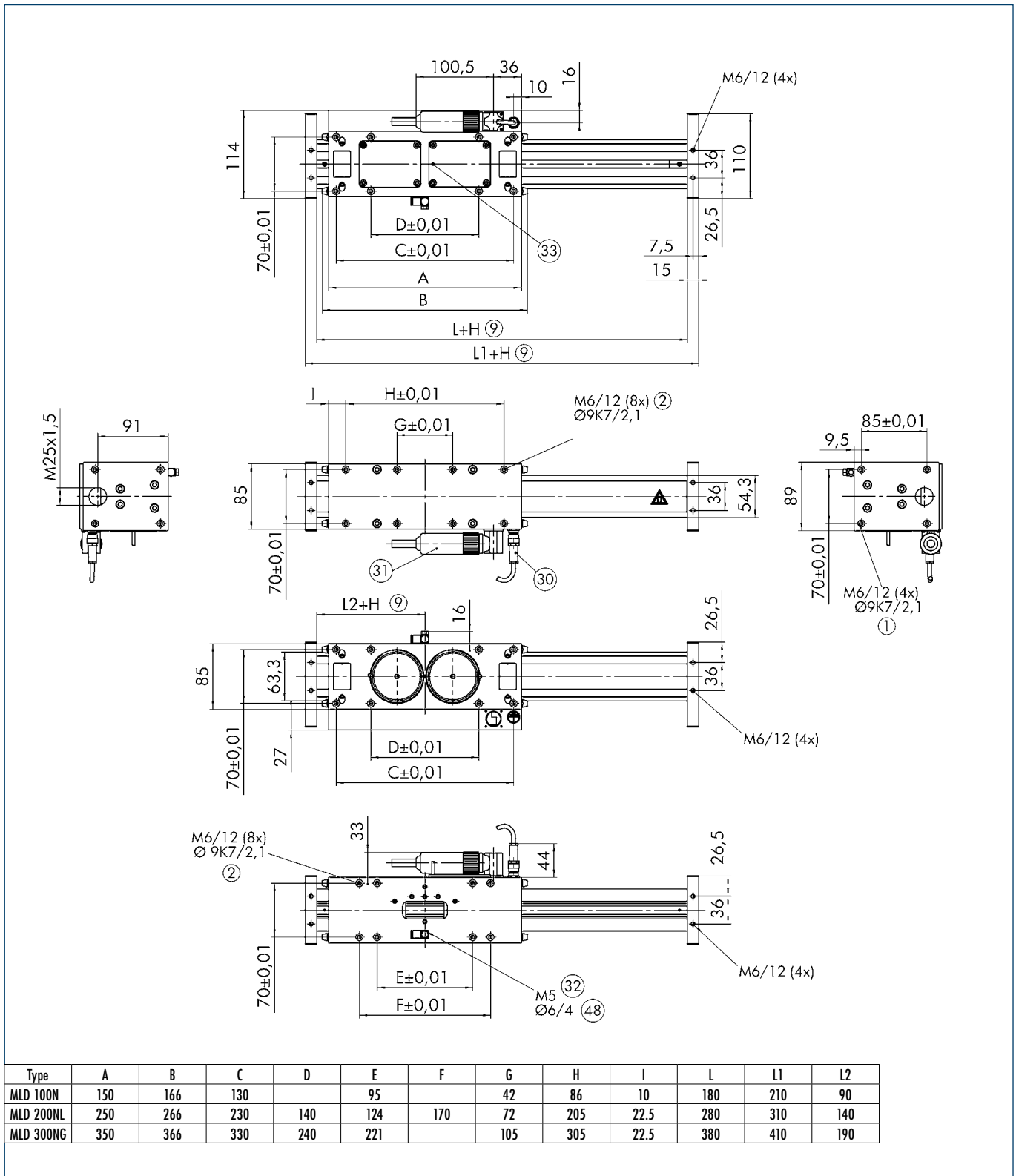

- ① Linear unit connection
- ② Assembly connection
- ③ Motor plug
- ④ Useful stroke
- ⑤ Hall sensor connecting plug
- ⑥ Compressed air connection
- ⑦ Cable for stroke measuring system
- ⑧ Hose diameter

Second slide (third slide only on request)

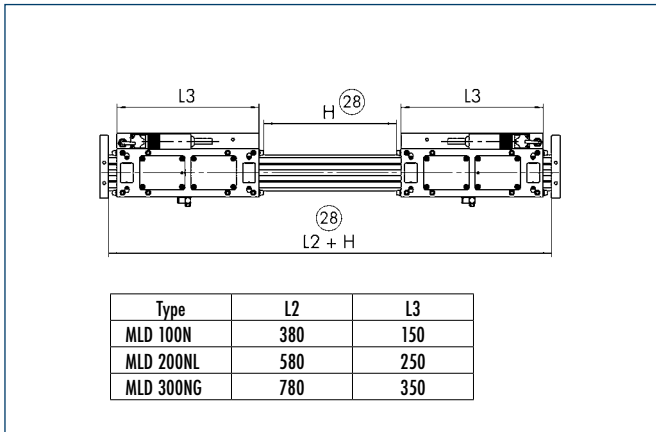

Ⓒ Total stroke = 2 x stroke per slide

Second passive slide

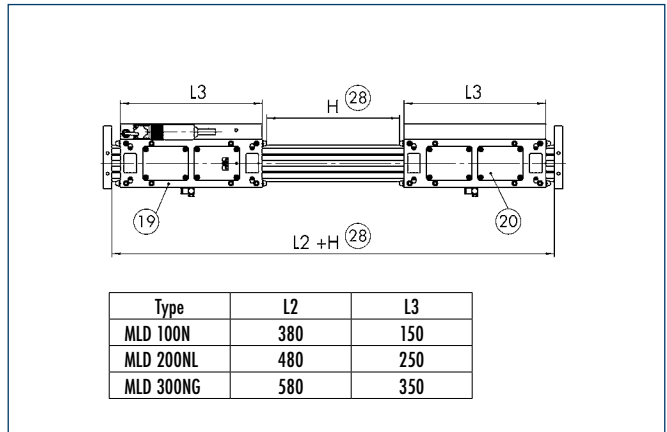

- Ⓐ Powered slide
- Ⓑ Passive slide
- Ⓒ Total stroke = 2 x stroke per slide

Wipers

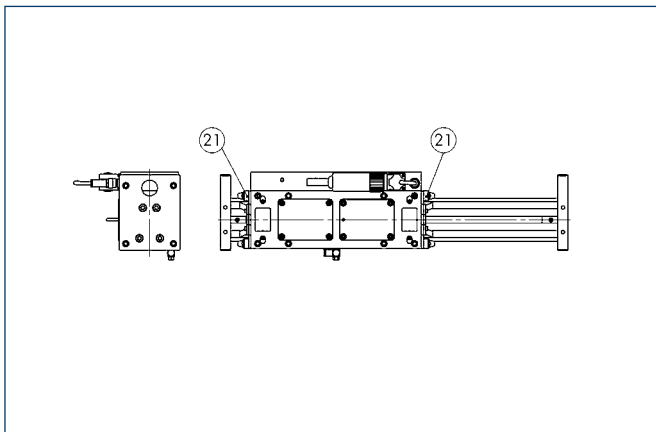

Ⓐ Wipers

ⓘ Using wipers shortens the useful stroke by 22 mm.

Limit and reference switch with one slide

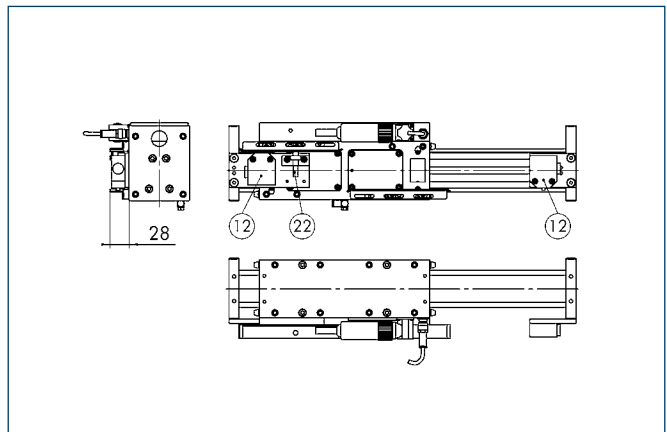

- Ⓐ Mechanical limit switches
- Ⓑ Inductive reference switch

Figure : Left reference switch

Limit and reference switch with two slides

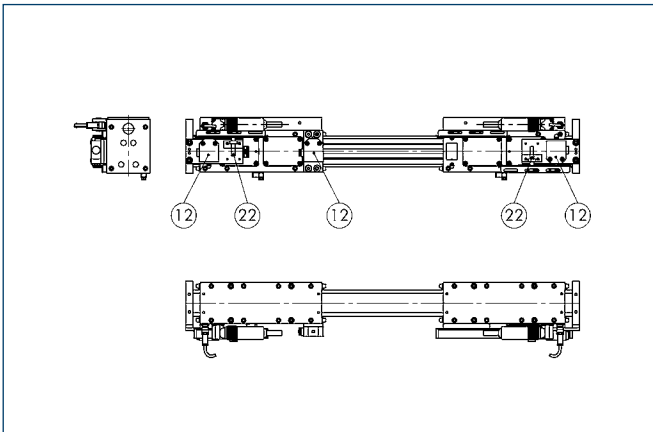

- ⑫ Mechanical limit switches
- ⑳ Inductive reference switch

Shock absorber

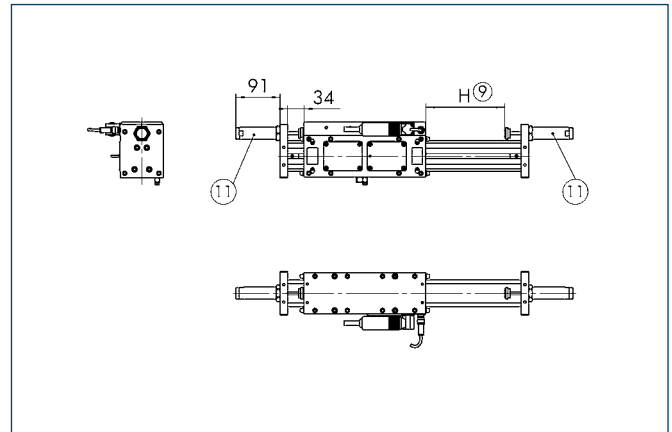

- ⑨ Useful stroke
- ⑪ Shock absorber

① Shock absorbers shorten the useful stroke by 42 mm, as the shock absorbers may not be actuated during axis operation.

Cable track for one motor slide

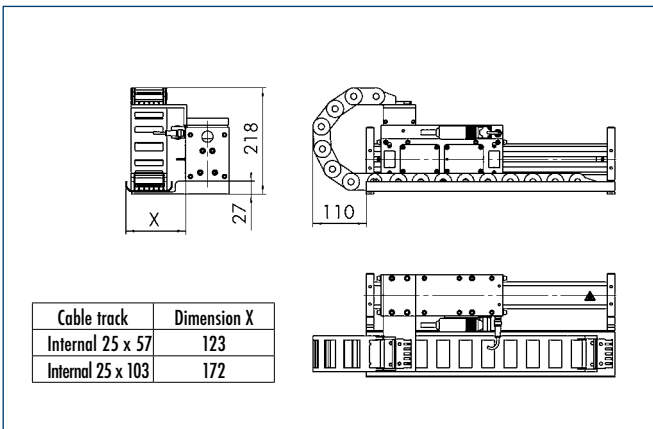
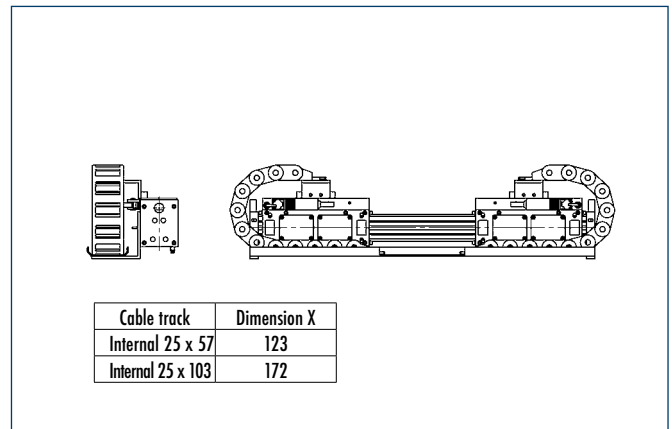

Figure : Cable track to left

XYZ for cable track width 50 mm
 XYZ for cable track width 100 mm

Cable tracks for two motor slides



XYZ for cable track width 50 mm
 XYZ for cable track width 100 mm

MLD N (NL/NG) component option codes and ordering

Each axis is supplemented with the required options. Each option is made up of 4 digits. The first two digits indicate the axis type. These are identical for all options for an axis. * The last two digits indicate the selectable options or accessories.

Option digits for axis types:
MLD 100N = 37xx
MLD 200NL = 38xx

MLD 300 NG = 39xx

Version	Description	Option
Active slide	1 slide	xx01
Motor for active slide with plug outlet	Left (completely assembled for INDRADRIIVE)	xx03
	Right (completely assembled for INDRADRIIVE)	xx04
	Left (completely assembled for SINAMICS)	xx58
	Right (completely assembled for SINAMICS)	xx59
Passive slide	1 slide	xx02 (n)**
Holding brake	Mounted in 1 active slide	xx05
Brake valve inc. 10m cable	for 1 slide	xx06
Wipers	mounted on slide	xx07
Reference switch	Inductive reference switches, left	xx08
	Inductive reference switches, right	xx09
	Inductive reference switches for 2 active slides	xx10
Limit switches	Inductive limit switches (right/left)	xx11
	Inductive limit switches for 2 active slides	xx12
	Mechanical limit switches (left/right)	xx13
	Mechanical limit switches for 2 active slides	xx14
Cable track	Narrow, attachment on left	xx15
	Narrow, attachment on right	xx16
	Narrow, for 2 slides left/right	xx17
	Wide, attachment on left	xx18
	Wide, attachment on right	xx19
	Wide, for 2 slides left/right	xx20
Shock absorber	2 units in set	xx21
	3 units in set (2 slides)	xx22
Centering sleeves	D = 9K7 in enclosed pack	xx24 (n)**
Standard cable sets	INDR. / Basic cable set, 5m straight	xx32
	INDR. / Basic cable set, 10 m straight	xx33
	INDR. / Basic cable set, 15 m straight	xx34
	INDR. / Basic cable set, 20 m straight	xx35
	INDR. / Adv. cable set, 5m straight	xx36
	INDR. / Adv. cable set, 10 m straight	xx37
	INDR. / Adv. cable set, 15 m straight	xx38
	INDR. / Adv. cable set, 20 m straight	xx39
	Sinamics cable set, 5 m	xx40
	Sinamics cable set, 10 m	xx41
Sinamics cable set, 15 m	xx42	
Sinamics cable set, 20 m	xx43	
Measuring system mounting kit	Four-digit code: (e.g. 0132) generated from following code:	
	Digit 1:	0
	Digit 2: Stroke measuring system type:	1 = Magnetic incremental linear unit 2 = Internal 3 = Absolute MSA 4 = Optical LIA
	Digit 3: Stroke measuring system cable length: (Corresponding to cable set length as standard)	1= 5m 2= 10m 3= 15m 4= 20m
	Digit 4: Drive controller cable version: (Corresponding to cable set version as standard)	1 = Internal 2 = BoschRexroth Indradrive BASIC 3 = BoschRexroth Indradrive ADVANCED 4 = SIEMENS Sinamics

Sample order

MLD 100N	-	1	-	150	-	nnn	-	3704 - 3711 - 3716 - 3724(6) - 3733 - 0132
Type of axis		Number of active slides		Useful stroke		Total length*** (added by Schunk)		List of required options

* The exception is the stroke measuring system option, which always appears last.

** Options with () contain the quantity of the options specified in brackets. For all options where the number automatically corresponds to the number of active slides, no quantity is specified.

*** Total length = Profile length + 2x end plate The only lengths available as the profile length for this axis type - due to the magnet - are xx05, xx20mm or xx80mm. The profile length is made up of the useful stroke, the total of the slide lengths and the safety reserve typical for the axis (14 mm) and is extended to the next technically feasible length by Schunk project engineers (wipers and shock absorbers are also taken into account). The Schunk useful stroke specification may slightly exceed the required useful stroke due to the permissible profile length. The total length is supplemented.

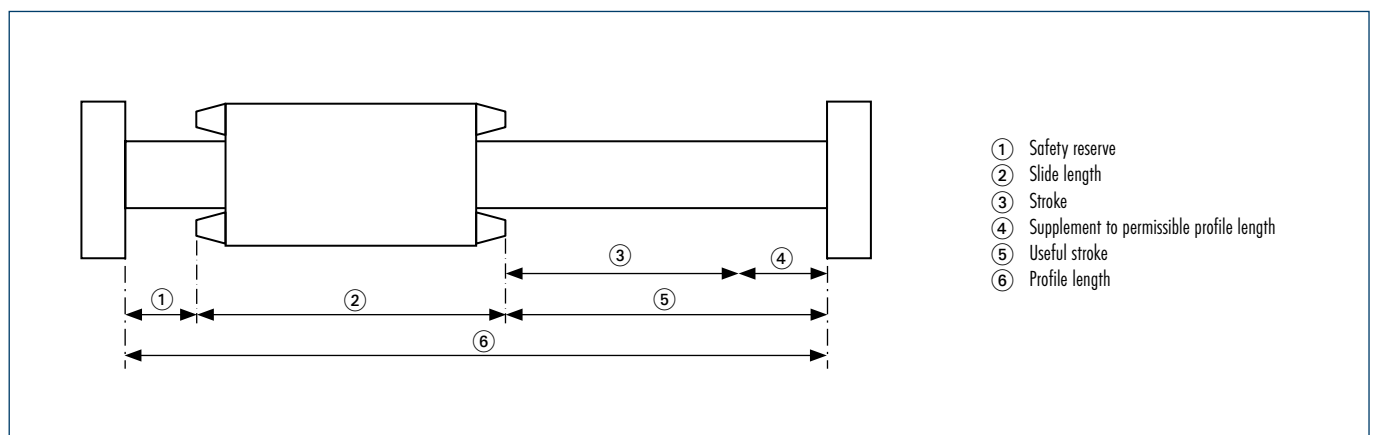

Scope of delivery includes

3-phase, electronically commutated AC synchronous linear motor with primary and secondary part, measuring system, profile guide with guide rollers, slide, profile end plates and with or without Hall sensor depending on the drive concept. Please specify other options when ordering.