

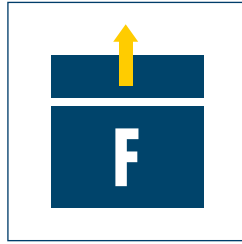

**Useful stroke**  
up to 400 mm

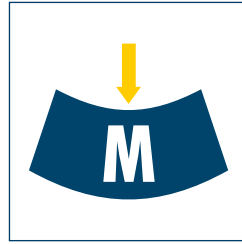

**Driving force**  
up to 500 N



**Deflection**  
up to 0.4 mm

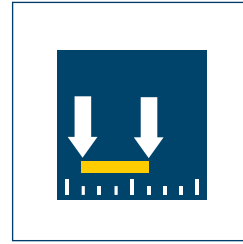

**Repeat accuracy**  
0.01 mm



**Max. speed**  
Up to 4 m/s

### Module design

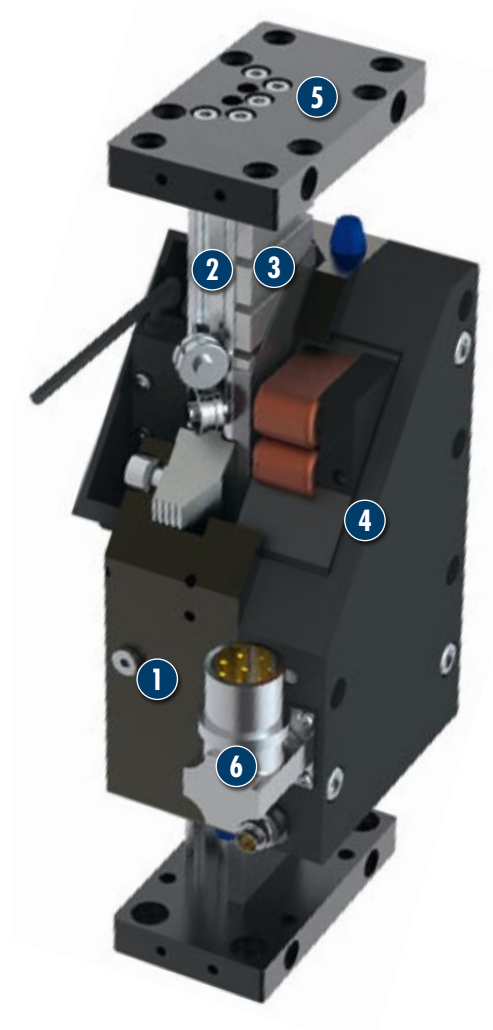

- 1** **Holding brake**  
Optional
- 2** **High precision, hardened and ground steel guide rails**  
for optimum guidance properties and speeds
- 3** **Integrated secondary parts**  
with high power magnets
- 4** **Compact primary part slide**  
with mounting surfaces, roller shoes adjusted without play and integrated measuring system
- 5** **End plates**  
for mounting sensors and shock absorbers
- 6** **Motor plug**  
Choice of position right/left

## Linear axis with direct drive

Standard short-stroke axis with integrated roller guide, primarily for vertical use

### Area of application

The compact and light short-stroke module for extremely dynamic positioning



### General information about the series

#### Drive

3-phase, electronically commutated AC synchronous linear motor. Primary part 3-phase copper coil body, secondary part iron mount with permanent magnets and protective cover.

#### Stroke measuring system

Non-contact magnetic measuring system with integrated analog signal output, 1 Vss (insensitive to contamination)

#### Profile guide

Hardened and ground steel guidance

#### Guided slide

Free from play, adjustable roller bearing, primary part and measuring system read head directly integrated, attachments mounted and secured using thread and centering sleeves on both side surfaces, wipers as standard

#### Operating temperature

From 10°C to 40°C

#### Accessories

- Control units from Bosch Rexroth or Siemens (other manufacturers on request)
- Limit switching using either mechanical precision switches or inductive sensors; referencing using inductive sensors
- Cable track, pre-assembled and mounted on drive
- Adapter plates on request
- Reinforcing plates (version MLD KT)
- Pneumatic brake to secure waste in case of power failure or emergency stop; optionally with brake valve consisting of switching valve and cable
- Alternative stroke measuring systems

#### Acceleration

Up to 40 m/s<sup>2</sup>

#### Useful loads

1 - 6 kg in vertical mode

#### Warranty

24 months

① Refer to ambient conditions on our introductory pages

For production reasons, the colors may vary from those shown in the catalog.



### Moment load

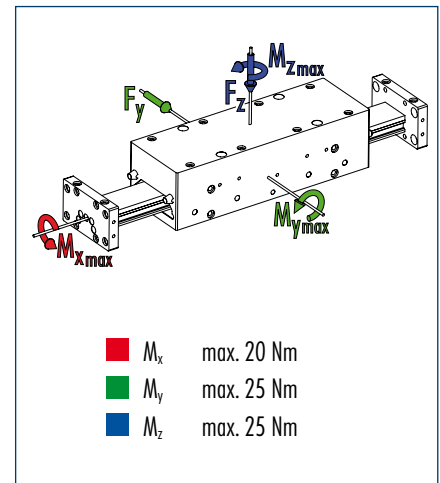

### Technical data

Designation		MLD 200K	MLD 200KT
Max. driving force (*)	[N]	500	500
Rated force (**)	[N]	136	136
Max. speed	[m/s]	4	4
Max. acceleration	[m/s <sup>2</sup> ]	40	40
Max. useful load (horizontal)	[kg]	6	6
Max. stroke	[mm]	300	300
Repeat accuracy (***)	[mm]	0.01	0.01
Measuring system resolution (controller-dependent)	[µm]	0.5	0.5
Max. current	( $A_{eff}$ )	16.2	16.2
Max. continuous current at standstill	( $A_{eff}$ )	3.8	3.8
Max. ambient temperature	[°C]	40	40
Max. surface temperature	[°C]	70	70
Weight of guided slide inc. motor	[kg]	4.0	4.0
Weight of end plates	[kg]	0.23	0.29
Profile / 100mm stroke	[kg]	0.34	0.47

(\*) Depending on controller type used

(\*\*) Depending on installation situation (heat dissipation)

(\*\*\*) The specified repeat accuracies are only applicable at constant ambient temperatures.

ⓘ The specified repeat accuracy applies at constant ambient temperatures.

Some of the specified forces can vary considerably when using different control units and with increasing travel speeds





### Limit and reference switches

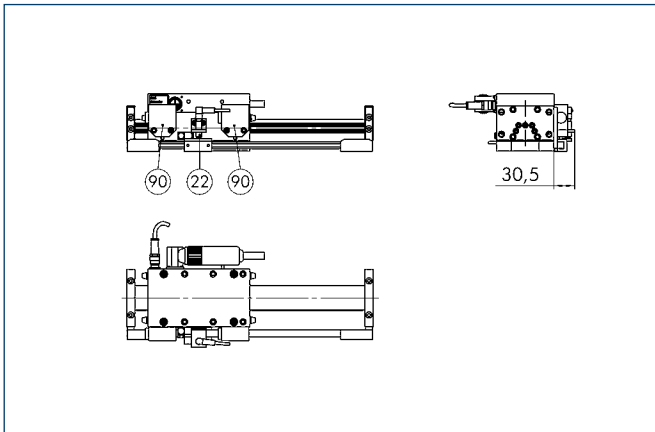

- ② Reference switch
- ⑨ Mechanical or inductive limit switch

### Cable track

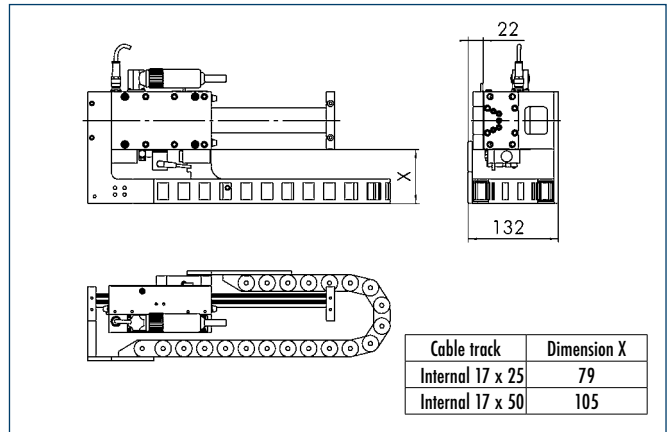

### MLD K(T) component option codes and ordering

Each axis is supplemented with the required options. Each option is made up of 4 digits. The first two digits indicate the axis type. These are identical for all options for an axis. \* The last two digits indicate the selectable options or accessories.

Option digits for axis types:

MLD 50K = 30xx

MLD 100K = 31xx

MLD 200K = 32xx

MLD 50 KT = 33xx

MLD 100 KT = 34xx

MLD 200 KT = 35xx

Version	Description	Option
Active slide	1 slide	xx01
Motor for active slide with plug outlet	Left (completely assembled for INDRADRIIVE)	xx03
	Right (completely assembled for INDRADRIIVE)	xx04
	Left (completely assembled for SINAMICS)	xx58
	Right (completely assembled for SINAMICS)	xx59
Passive slide	1 slide	-
Holding brake	Mounted in 1 active slide	xx05
Brake valve inc. 10m cable	for 1 slide	xx06
Wipers	Mounted on slide as standard	-
Reference switch	Inductive reference switches	xx08
Limit switches	Inductive limit switches	xx11
	Mechanical limit switches	xx13
Cable track	Narrow, attachment on left	xx15
	Narrow, attachment on right	xx16
	Narrow, for 2 slides left/right	-
	Wide, attachment on left	xx18
	Wide, attachment on right	xx19
	Wide, for 2 slides left/right	-
Centering sleeves	D = 9K7 in enclosed pack	xx24 (n)**
Standard cable sets	INDR. / Basic cable set, 5m straight	xx32
	INDR. / Basic cable set, 10 m straight	xx33
	INDR. / Basic cable set, 15 m straight	xx34
	INDR. / Basic cable set, 20 m straight	xx35
	INDR. / Adv. cable set, 5m straight	xx36
	INDR. / Adv. cable set, 10 m straight	xx37
	INDR. / Adv. cable set, 15 m straight	xx38
	INDR. / Adv. cable set, 20 m straight	xx39
	Sinamics cable set, 5 m	xx40
	Sinamics cable set, 10 m	xx41
	Sinamics cable set, 15 m	xx42
	Sinamics cable set, 20 m	xx43

Measuring system mounting kit

Four-digit code: (e.g. 0132) generated from following code:

	Digit 1	Digit 2	Digit 3	Digit 4
	0	1	3	2
Digit 1:	0			
Digit 2: Stroke measuring system type:	1 = Magnetic incremental linear unit			
	2 = Internal			
	3 = Absolute MSA			
	4 = Optical LIA***			
Digit 3: Stroke measuring system cable length: (Corresponding to cable set length as standard)	1= 5m			
	2= 10m			
	3= 15m			
	4= 20m			
Digit 4: Drive controller cable version: (Corresponding to cable set version as standard)	1 = Internal			
	2 = BoschRexroth Indradrive BASIC			
	3 = BoschRexroth Indradrive ADVANCED			
	4 = SIEMENS Sinamics			

### Sample order

MLD 100KT	-	1	-	150	-	nnn	-	3404 - 3411 - 3416 - 3424(6) - 3433 - 0132
Type of axis		Number of active slides		Useful stroke		Total length**** (added by Schunk)		List of required options

\* The exception is the stroke measuring system option, which always appears last.

\*\* Options with ( ) contain the quantity of the options specified in brackets. For all options where the number automatically corresponds to the number of active slides, no quantity is specified.

\*\*\* CAUTION: Cannot be used for MLD 50K and MLD 50K

\*\*\*\* Total length = Profile length + 2x end plate  
 The only lengths available as the profile length for this axis type - due to the magnet - are xx38mm and xx88mm.  
 The profile length is made up of the useful stroke, the total of the slide lengths and the safety reserve typical for the axis (22 mm) and is extended to the next technically feasible length by Schunk project engineers (wipers and shock absorbers are also taken into account). The Schunk useful stroke specification may slightly exceed the required useful stroke due to the permissible profile length. The total length is supplemented.

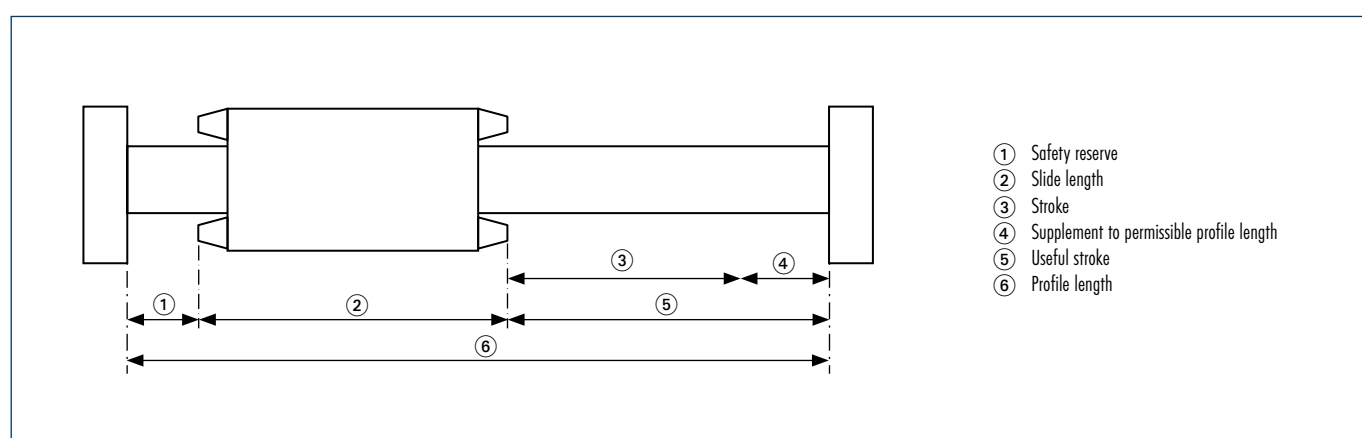

### Scope of delivery includes

3-phase, electronically commutated AC synchronous linear motor with primary and secondary part, measuring system, profile guide with guide rollers, slide, profile end plates and with or without Hall sensor depending on the drive concept. Please specify other options when ordering.