

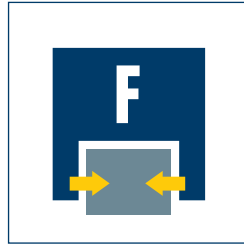

Size
64



Weight
1 kg
2.20 lbs



Gripping force
up to 500 N
up to 112 lbf



Stroke per finger
6 mm
0.236 in



Workpiece weight
2.5 kg
5.51 lbs

Application example

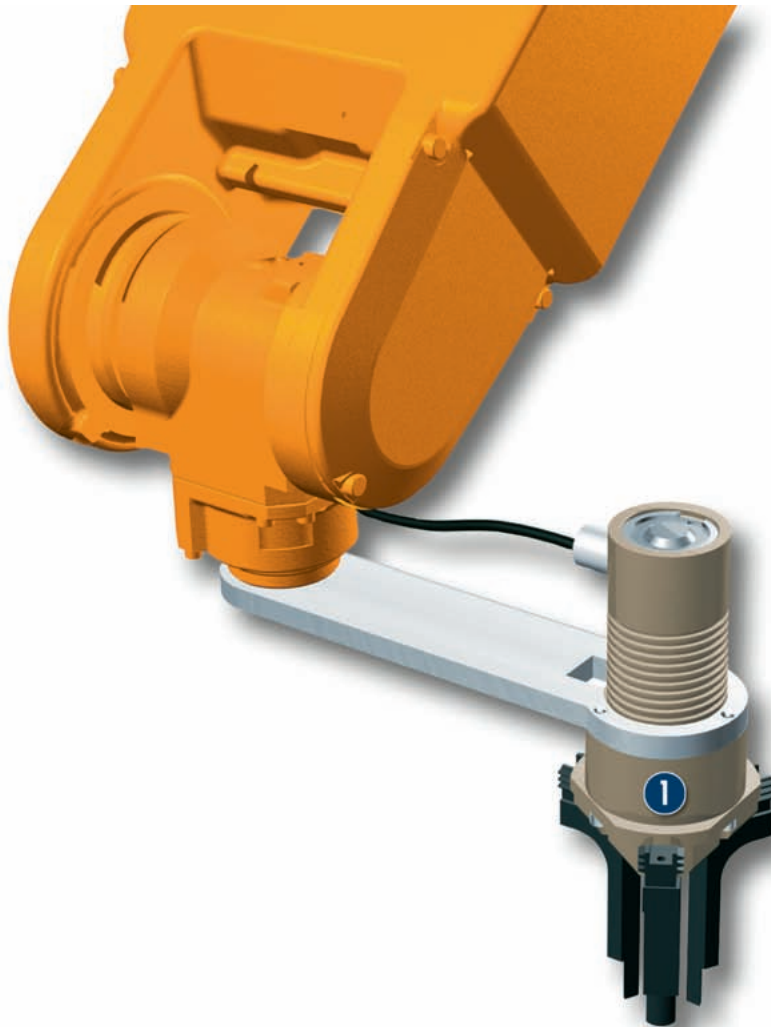

Connection via adapters to robots for handling all kinds of components – a complete application solution without pneumatics

1 EZN 064 servo-electric 3-Finger Centric Gripper

Universal Gripper

Servo-electric 3-finger centric gripper with large gripping force and high moment capabilities thanks to multiple-tooth guide

Area of application

Ideal standard solution for numerous areas of application. Highly versatile thanks to controlled gripping force, position and speed

Your advantages and benefits

Drive design of servo-motor

for flexibility in use

Control via digital and analog control signals

for simple integration in existing control systems

Pre-positioning capability

to reduce cycle times through a short working stroke

Robust multiple-tooth guidance

for precise handling

High maximum moments possible

suitable for the use of long gripper fingers

Mounting from one side in two screw directions

for universal and flexible gripper assembly



General information on the series

Working principle

Wedge-hook kinematics

Housing material

Aluminum alloy, hard-anodized

Base jaw material

Steel

Actuation

Servo-electric, by brushless DC servo-motor. A servo-controller is needed to actuate the gripper. We recommend the EGN-C for this purpose.

Warranty

24 months

Scope of delivery

9-pin Sub-D connector, centering sleeves, assembly and operating manual with manufacturer's declaration on CD-ROM

Sectional diagram

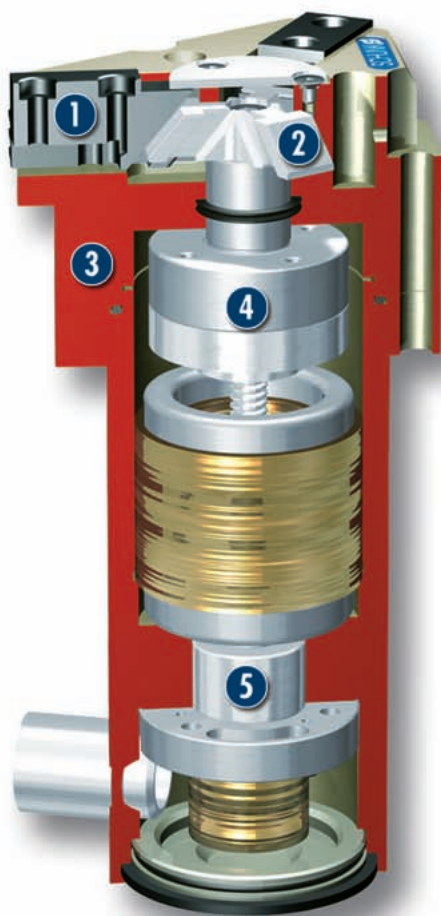

- 1 Base jaws**
with multiple-tooth guidance for precise gripping even with long gripper fingers
- 2 Kinematics**
wedge-hook system for high power transmission and centric clamping
- 3 Housing**
weight-reduced through the use of a hard-anodized, high-strength aluminum alloy
- 4 Kinematics**
roller-bearing mounted spindle nut system for transferring the rotational movement of the servo-motor into the axial movement of the piston rod
- 5 Drive**
DC servo-motor with resolver

Function description

The roller-bearing mounted spindle nut transforms the rotational movement of the servo-motor into the axial movement of the wedge hook. Through its angled active surfaces, the wedge hook transforms this motion into the lateral, synchronous gripping movement of all base jaws.

Electrical actuation

The EZN is electrically actuated by the associated EZN-C control electronics. The control electronics can be integrated in the higher-level servo-controlled concept either via conventional digital and analog inputs/outputs or via the CAN-Bus (CAN-open protocol) or RS-485 communication interfaces. If integration takes place simply by terminal signals, the gripping parameters force, position and speed and the different operating modes are defined by digital and analog inputs. The gripper status can be monitored by means of digital and analog outputs.

Accessories

Accessories from SCHUNK – the suitable complement for the highest level of functionality, reliability and controlled production of all automation components.

Centering sleeves



HUE protective cover



BSWS quick-change jaw system



Finger blanks



FMS force measuring system



Controllers



① For the exact size of the required accessories, availability of this size and the designation and ID, please refer to the additional views at the end of the specific size. You can find more detailed information on our accessory range in the "Accessories" catalog section.

General information on the series

Gripping force

is the arithmetic total of the gripping force applied to each jaw at distance P (see illustration), measured from the upper edge of the gripper.

Finger length

is measured from the upper edge of the gripper housing in the direction of the main axis.

Repeat accuracy

is defined as the spread of the limit position after 100 consecutive strokes.

Workpiece weight

The recommended workpiece weight is calculated for a force-type connection with a coefficient of friction of 0.1 and a safety factor of 2 against slippage of the workpiece on acceleration due to gravity g. Considerably heavier workpiece weights are permitted with form-fit clamping.

Closing and opening times

Closing and opening times are purely the times that the base jaws or fingers are in motion. Valve switching times, hose filling times or PLC reaction times are not included in the above times and must be taken into consideration when determining cycle times.





Gripping force, I.D. gripping

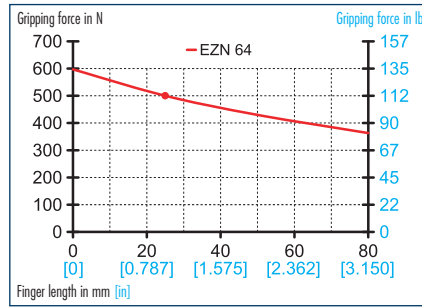

Finger load

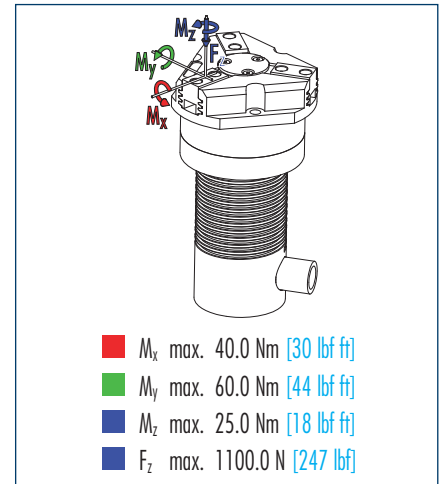

① Moments and forces apply per base jaw and may occur simultaneously. M_y may arise in addition to the moment generated by the gripping force itself. If the max. permitted finger weight is exceeded, it is imperative to reduce the speed so that the jaw movement occurs without any hitting or bouncing. Tool life may be reduced.

Technical data

Designation	EZN 64	
Mechanical gripper operating data	ID	0306005
Stroke per finger	mm [in]	6.0 [0.236]
Constant gripping force (100 % continuous duty)	N [lbf]	220.0 [49]
Max. gripping force	N [lbf]	500.0 [112]
Min. gripping force	N [lbf]	70.0 [15.7]
Weight	kg [lbs]	0.98 [2.16]
Recommended workpiece weight	kg [lbs]	2.5 [5.51]
Closing time	s	0.25
Opening time	s	0.25
Max. permitted finger length	mm [in]	80.0 [3.150]
Max. permitted weight per finger	kg [lbs]	0.35 [0.77]
IP rating		40
Min. ambient temperature	°C [°F]	5.0 [41]
Max. ambient temperature	°C [°F]	55.0 [131]
Repeat accuracy	mm [in]	0.01 [0.0004]
Positioning accuracy	mm [in]	on request
Max. speed	mm/s	40.0
Max. acceleration	mm/s ²	2137.0
Controller operating data		
Terminal voltage	V	24.0
Nominal current	A	2.7
Maximum current	A	5.9
Resolution	mm [in]	on request
Controller operating data	ID	0307002
Integrated electronics		No
Voltage supply	VDC	24.0
Nominal current	A	6.0
Maximum current	A	12.0
Sensor system		Resolver
Interface		I/O; RS 485; CAN
Weight	kg [lbs]	0.98 [2.16]
IP rating		30

Main views

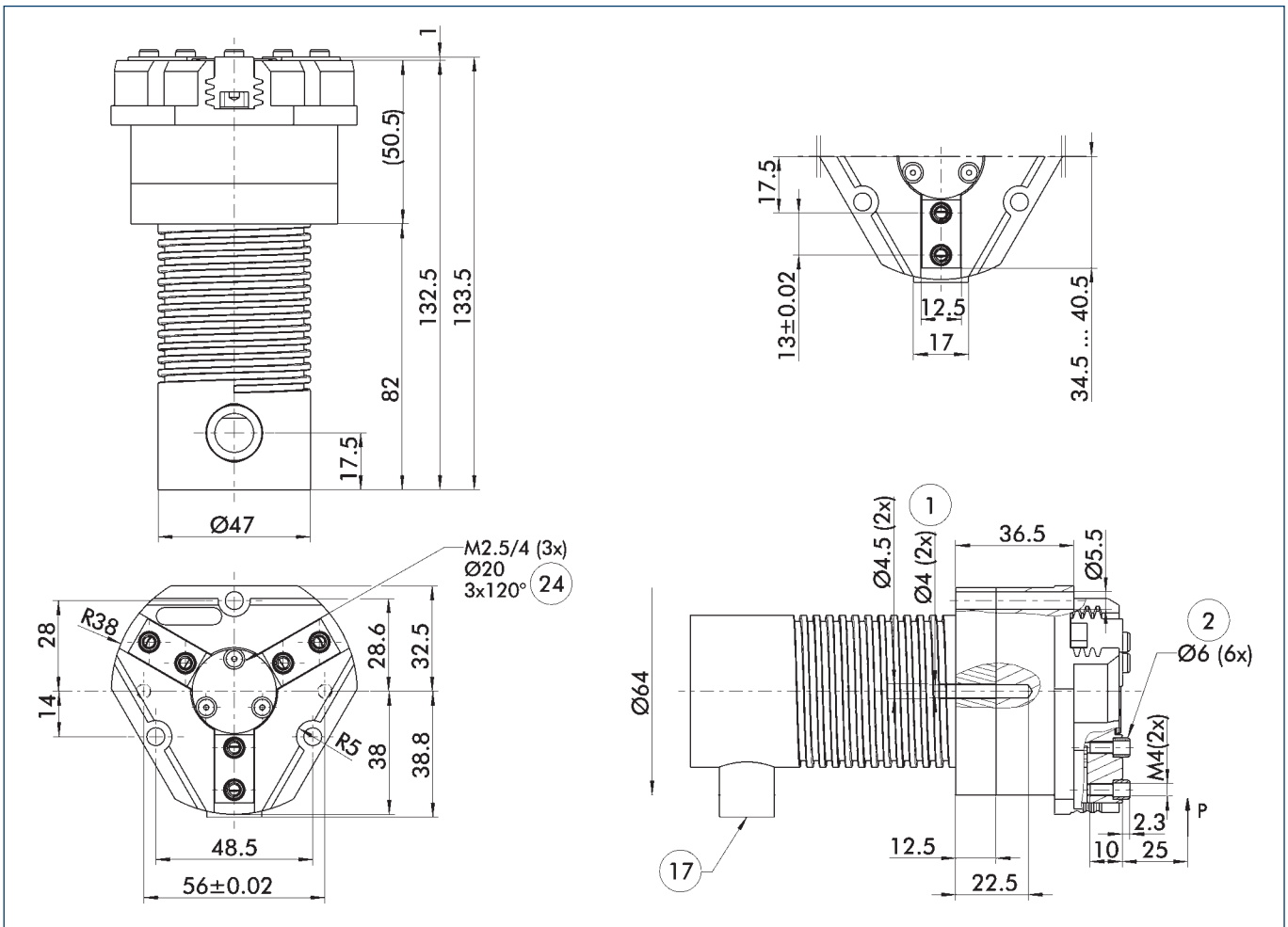

The drawing shows the gripper in the basic version with closed jaws, the dimensions do not include the options described below.

- ① Gripper connection
- ② Finger connection
- ⑬ Cable outlet
- ⑭ Screw pitch circle

Actuation

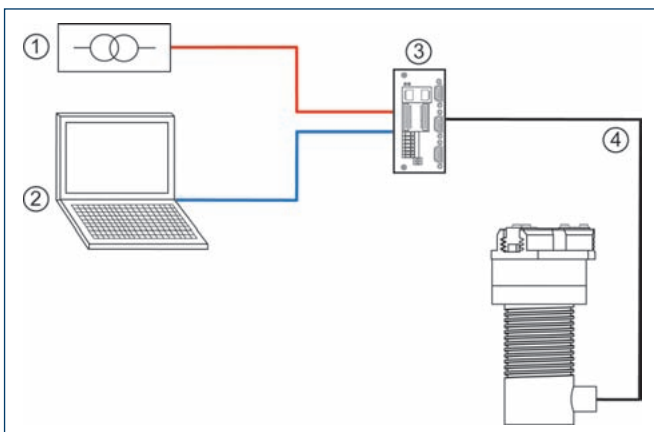

- ① 24 VDC power supply provided by the customer
- ② Control (PLC or similar) provided by the customer
- ③ EZN-C external control electronics (ID No. 0307725)
- ④ Control electronics/gripper interconnecting cables (5 m cables are included in the scope of delivery, mounted to the gripper)

Finger blanks

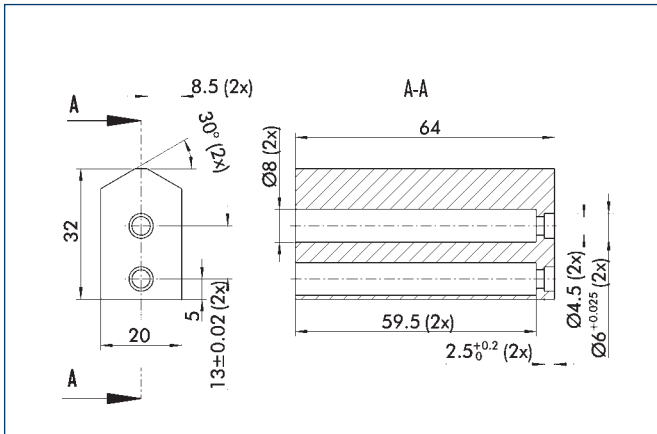

Finger blanks for customized subsequent machining

Designation	Housing material	Scope of delivery	ID
ABR-plus 64	Aluminum	1	0300010
SBR-plus 64	1.6 MnCr 5	1	0300020

FMS force measuring jaws

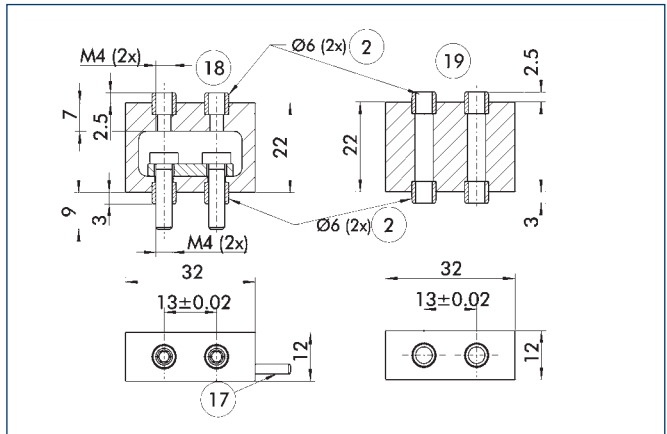

- ② Finger connection
- ⑰ Cable outlet
- ⑱ Fine serration
- ⑲ Air connection

Force measuring jaws measure gripping forces, but can also determine workpiece weights or dimensional deviations. There are active and passive intermediate jaws (FMS-ZBA or FMS-ZBP). At least one active force measuring jaw is required per gripper, the rest can be passive. For each active jaw, an FMS-A1 electronic processor and an FMS-AK connection cable are required.

Designation	ID
FMS-A1	0301810
FMS-AK10	0301822
FMS-AK2	0301820
FMS-AK20	0301823
FMS-AK5	0301821
FMS-ZBA 64	0301832
FMS-ZBP 64	0301833

BSWS quick-change jaw system

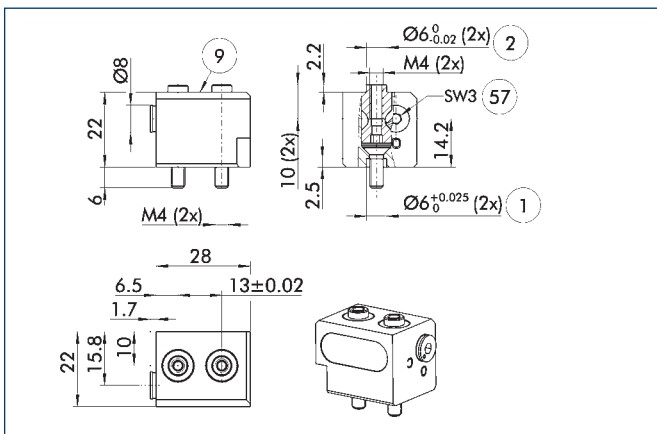

- ① Gripper connection
- ② Finger connection
- ⑨ For screw connection diagram, see basic version
- ⑤ Locking mechanism

The BSWS quick-change jaw system enables top jaws to be changed on the gripper manually and rapidly. An adapter (BSWS-A) and a base (BSWS-B) are required for each gripper jaw.

Designation	ID
BSWS-A 64	0303022
BSWS-B 64	0303023

You can find more detailed information and individual parts of the above-mentioned accessories in the "Accessories" catalog section.