

B 100-ZRS/-ZSS

Linear Axes • Toothed-belt Drive

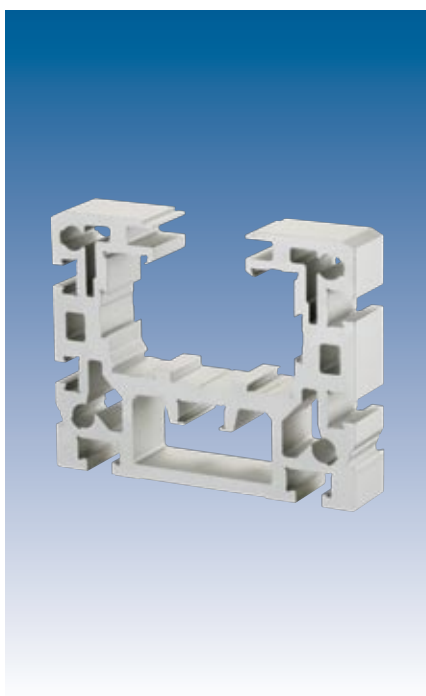

Advantages of roller guide

High maximum moments
due to optimum force transmission to the profile

Long stroke lengths
can be achieved with no problems

Life-time lubricated rollers
for easy maintenance use

Smooth, low-noise running

Advantages of profiled rail guide

High load bearing capacity

Long lifetime

High precision

Loads and load torques

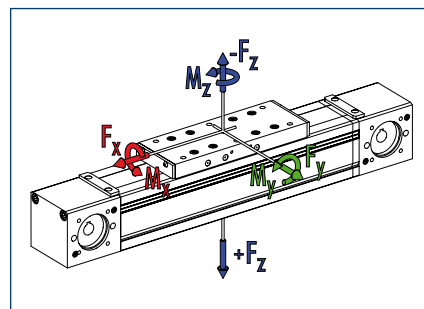

Load		ZRS dynamic	ZSS dynamic
■ F_x^{**}	[N]	2800	2800
■ F_y	[N]	1000	1000
■ F_z	[N]	2500	3000
■ $-F_z$	[N]	1200	2000
Load torques		ZRS dynamic	ZSS dynamic
■ M_x	[Nm]	200	200
■ M_y	[Nm]	250 (350)	300 (420)
■ M_z	[Nm]	200 (280)	300 (420)
■ M_{zmax}	[Nm]	91.6	91.6

** Maximum value = Depending on speed

① Values in brackets relate to the long slide.

Technical data

Designation		B 100-ZRS	B 100-ZSS
Max. travel speed	[m/s]	8	5
Repeat accuracy	[mm]	± 0.08	± 0.08
Max. acceleration	[m/s ²]	40	40
Idle torque	[Nm]	2.5	2.5
Drive			
Drive element	Toothed belt	40 AT 10	40 AT 10
Travel per revolution	[mm]	200	200
Maximum stroke	[mm]	7420	7420
Max. total length	[mm]	7900	7900
Moment of inertia	[kgm ²]	0.013	0.0126
Weights			
Basic without travel	[kg]	9.5	9.1
Travel per 100 mm	[kg]	1.1	1.45
Slide plate 280 mm	[kg]	4.1	3.8
Slide plate 400 mm	[kg]	5.85	5.43

Main views

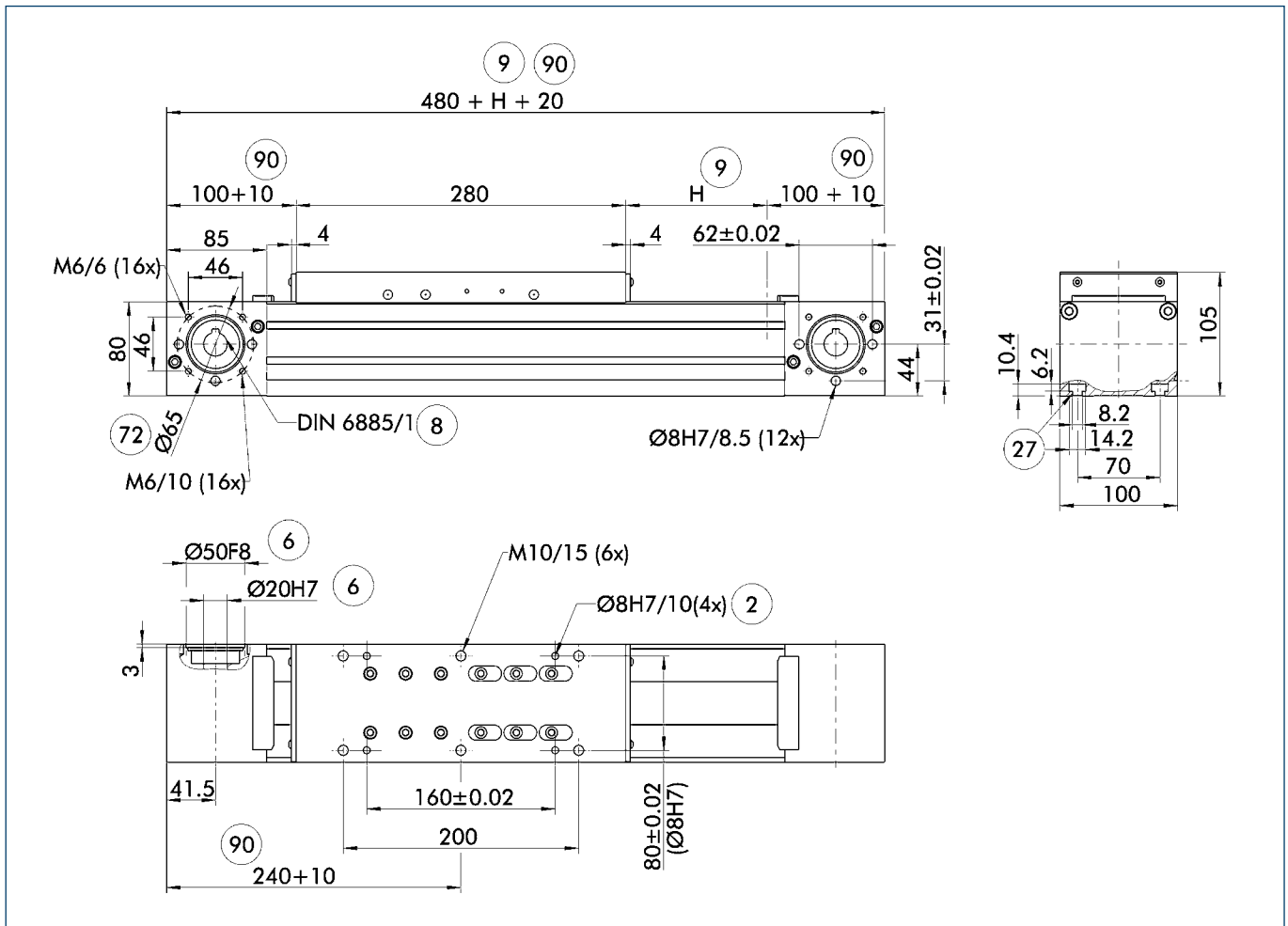

- ② Assembly connection
- ⑥ Drive connection
- ⑧ Feather key DIN 6885
- ⑨ Useful stroke
- ②⑦ Mounting groove for T-nuts
- ⑦② Bolt pitch circle
- ⑨⑩ Change of dimension with optional cover tape

Long slide

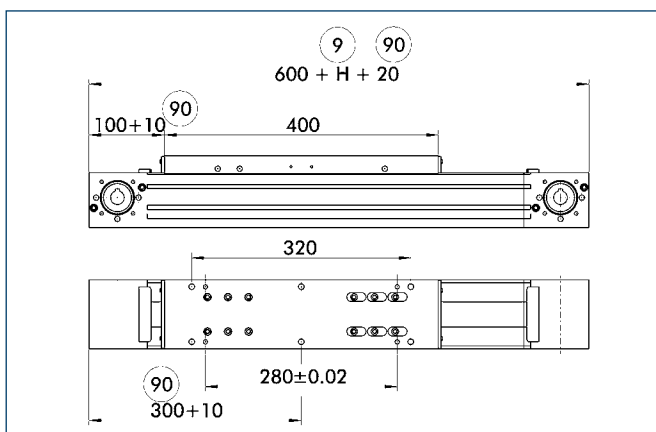

- ⑨ Useful stroke
- ⑨⑩ Change of dimension with optional cover tape

Drive journal connection dimensions

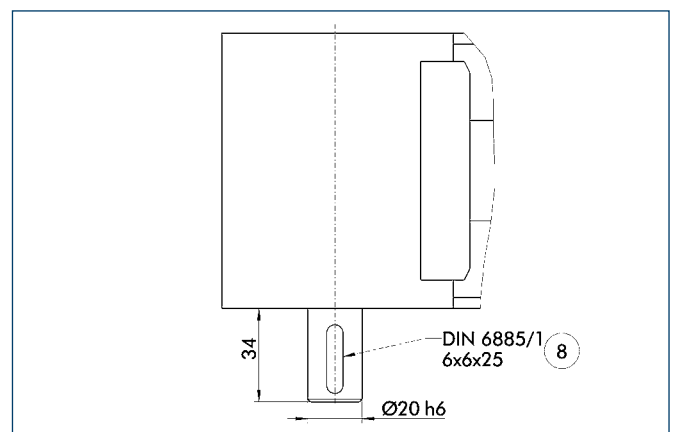

- ⑧ Feather key

B 100-ZRS/-ZSS

Linear Axes • Toothed-belt Drive

Profile ZRS/ZSS

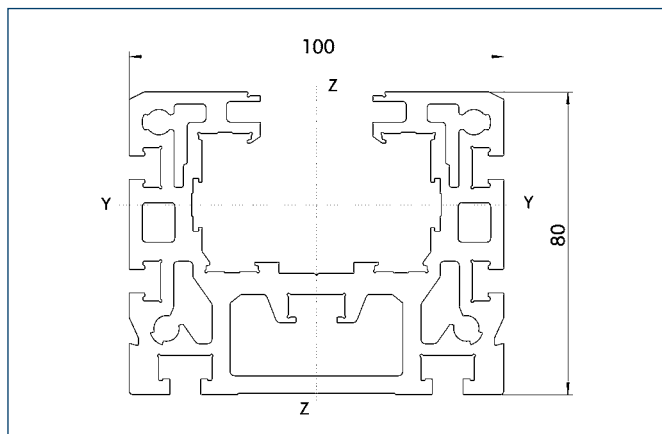

Specific mass	[kg/m]	7.97
Planar dimension	[mm ²]	2950
Planar moment of inertia I _y	[mm ⁴]	1782959
Planar moment of inertia I _z	[mm ⁴]	3507213
Load torque W _y	[mm ³]	40598
Load torque W _z	[mm ³]	70137

Mounting

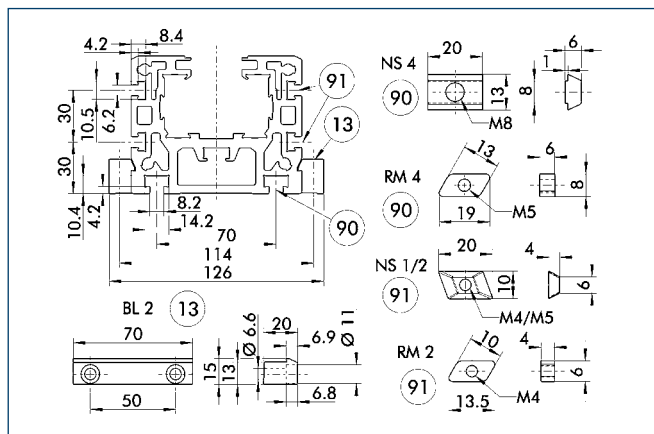

- 13 Mounting strip
- 90 T-nut on base side
- 91 Side T-nut

The profile can be secured either using T-nuts or mounting strips.

Designation	Order designation	ID no.
T-nut	NS1	0331404
T-nut	NS2	0331405
T-nut	NS4	0331407
T-nut	RM2	0331425
T-nut	RM4	0331426
Mounting strip	BL2	0331401

Motor flange schematic diagram

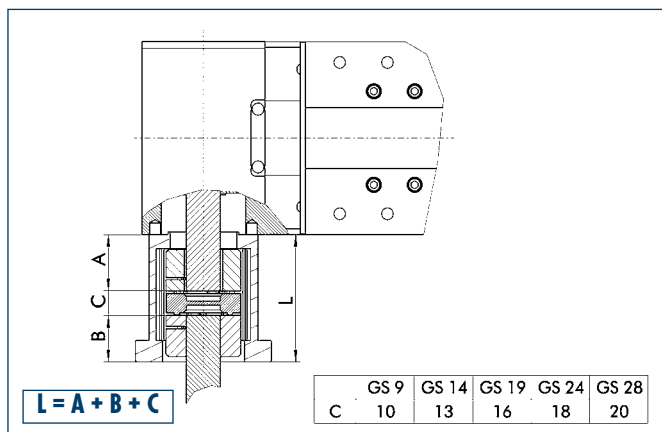

The table shows the relevant dimension **C** of the standard couplings. For dimension **A** refer to drive journal connection dimensions, for dimension **B** refer to corresponding motor dimension sheet, dimension **L** may differ in individual cases.

Different drive solutions can be attached to our axes. SCHUNK can supply you with the right motor flange and coupling for your drive.

ⓘ Because of the different thermal behavior of motors, we recommend that the drive solution is tested by the motor manufacturer.

More detailed information on pedestal bearings, connection shafts and bevel gears can be found in the "OPTIONS for System HSB" section of the catalog.

Limit switch position

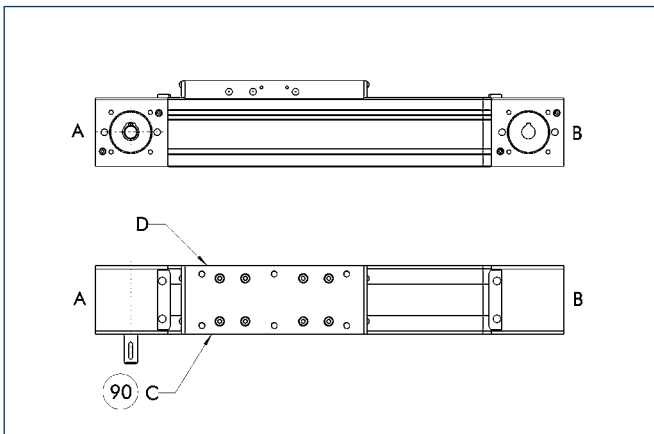

90 Limit switch standard position

Two E02 switches are used as limit switches and an RS2 as the reference switch as standard.

① The positions and dimensions of limit switches, switching lugs, and mounting components may vary depending on the application and the selected limit switches. Please contact us for assistance.

Limit switch selection

Designation	Order designation	ID no.
Inductive limit switch, opener, 2 m cable	E02	0331410
Inductive limit switch, opener, 10 m cable	E010	0331412
Inductive limit switch, closer, 2 m cable	ES2	0331411
Inductive limit switch, closer, 10 m cable	ES10	0331413
Mechanical limit switch (Siemens), opener	EMS	0331414
Mechanical limit switch (Balluff), opener	EMB	0331415

Lubrication connections

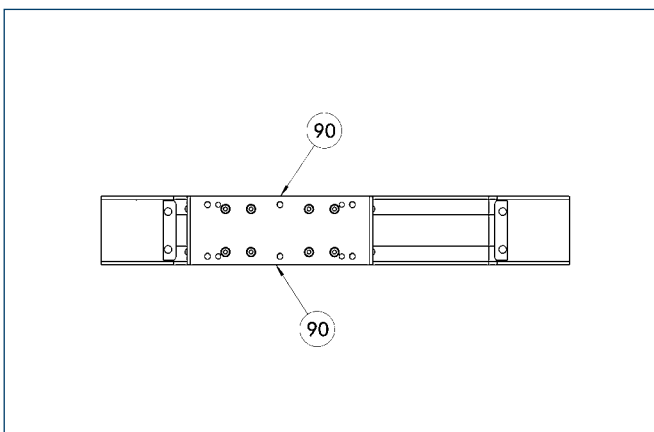

90 Standard lubrication connection

Standard connection

Lubrication nipple M8x1

If the lubrication connection has a different seat, this must be defined in the order text.

Drive shafts

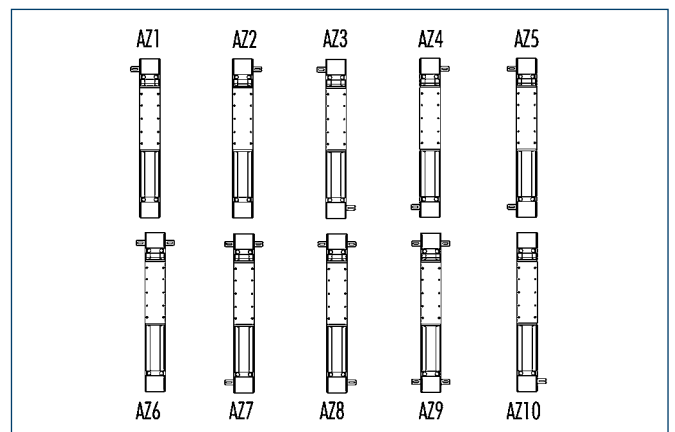

Depending on the axis application, the drive shaft seat may need to be defined in the order text. Particularly with axis combinations and mechanical synchronization, multiple drive shafts - some of them continuous shafts - are required.



More detailed information on pedestal bearings, connection shafts and bevel gears can be found in the "OPTIONS for System HSB" section of the catalog.