

B 140C-ZSS

Linear Axes • Toothed-belt Drive

Advantages of profiled rail guide

- High load bearing capacity
- Long lifetime
- High precision

Loads and load torques

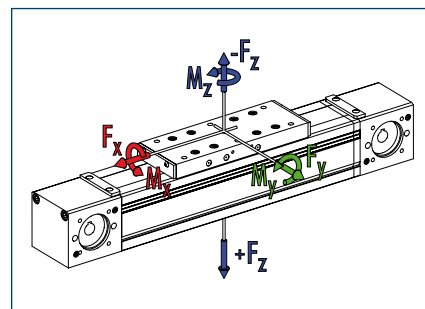

Load		Dynamic
■ F_x^{**}	[N]	4000
■ F_y	[N]	3200
■ F_z	[N]	7500
■ $-F_z$	[N]	5000
Load torques		Dynamic
■ M_x	[Nm]	600
■ M_y	[Nm]	1200 (1700)
■ M_z	[Nm]	1200 (1700)
■ M_{Amox}	[Nm]	143.6

** Maximum value = Depending on speed

① Values in brackets relate to the long slide.

Technical data

Designation		B 140C-ZSS
Max. travel speed	[m/s]	5
Repeat accuracy	[mm]	± 0.08
Max. acceleration	[m/s ²]	60
Idle torque	[Nm]	3.5
Drive		
Drive element	Toothed belt	50 AT 10-E
Travel per revolution	[mm]	220
Maximum stroke	[mm]	7470
Max. total length	[mm]	8100
Moment of inertia	[kgm ²]	0.02
Weights		
Basic without travel	[kg]	15.0
Travel per 100 mm	[kg]	1.7
Slide plate 320 mm	[kg]	7.5
Slide plate 500 mm	[kg]	11.7

B 140C-ZSS

Linear Axes • Toothed-belt Drive

Profile ZSS

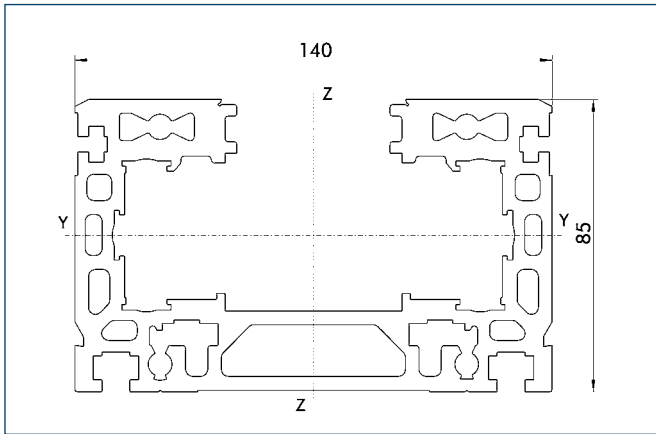

Specific mass	[kg/m]	10.11
Planar dimension	[mm ²]	3743
Planar moment of inertia I _y	[mm ⁴]	3127894
Planar moment of inertia I _z	[mm ⁴]	9071334
Load torque W _y	[mm ³]	67067
Load torque W _z	[mm ³]	129589

Mounting

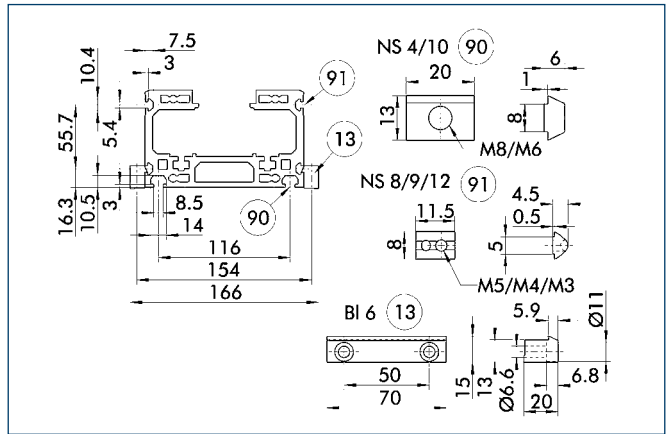

- 13 Mounting strip 90 T-nut on base side
91 Side T-nut

The profile can be secured either using T-nuts or mounting strips.

Designation	Order designation	ID no.
T-nut	NS4	0331407
T-nut	NS8	0331420
T-nut	NS9	0331421
T-nut	NS10	0331422
T-nut	NS12	0331424
Mounting strip	BL6	0331428

Motor flange schematic diagram

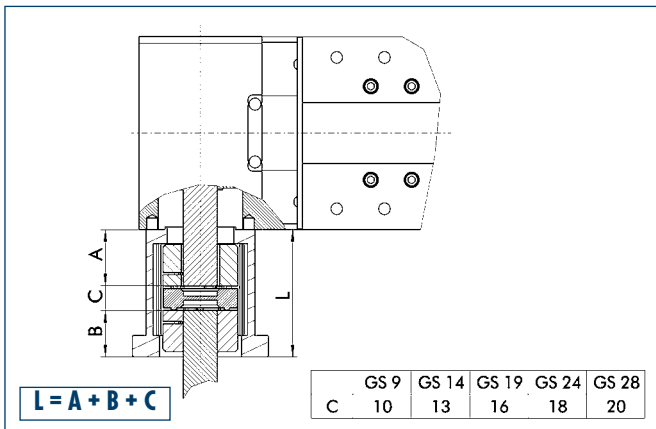

The table shows the relevant dimension **C** of the standard couplings. For dimension **A** refer to drive journal connection dimensions, for dimension **B** refer to corresponding motor dimension sheet, dimension **L** may differ in individual cases.

Different drive solutions can be attached to our axes. SCHUNK can supply you with the right motor flange and coupling for your drive.

① Because of the different thermal behavior of motors, we recommend that the drive solution is tested by the motor manufacturer.

Limit switch position

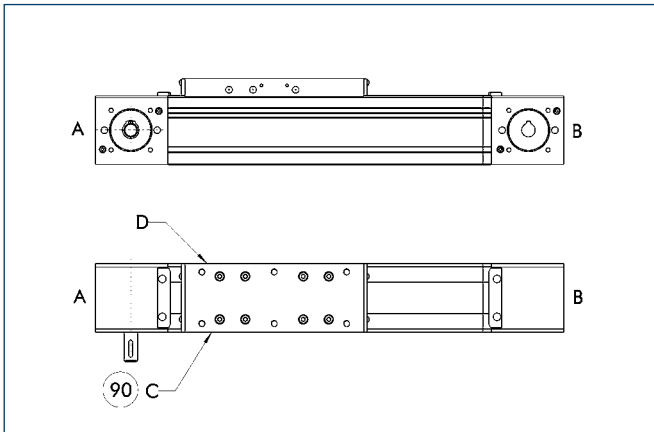

90 Limit switch standard position

Two E02 switches are used as limit switches and an RS2 as the reference switch as standard.

① The positions and dimensions of limit switches, switching lugs, and mounting components may vary depending on the application and the selected limit switches. Please contact us for assistance.

Limit switch selection

Designation	Order designation	ID no.
Inductive limit switch, opener, 2 m cable	E02	0331410
Inductive limit switch, opener, 10 m cable	E010	0331412
Inductive limit switch, closer, 2 m cable	ES2	0331411
Inductive limit switch, closer, 10 m cable	ES10	0331413
Mechanical limit switch (Siemens), opener	EMS	0331414
Mechanical limit switch (Balluff), opener	EMB	0331415

Lubrication connections

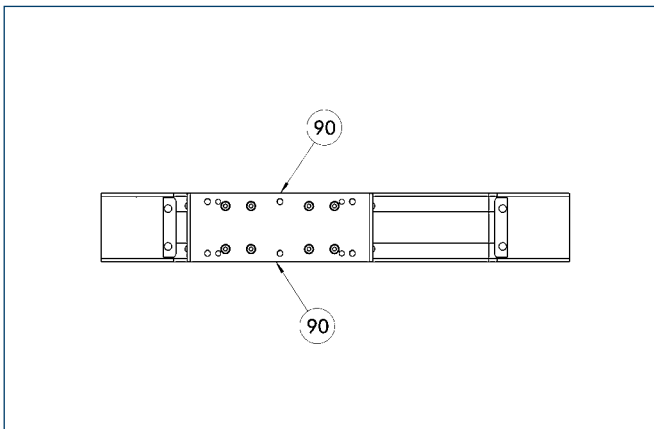

90 Standard lubrication connection

Standard connection

Lubrication nipple M8x1

If the lubrication connection has a different seat, this must be defined in the order text.

Drive shafts

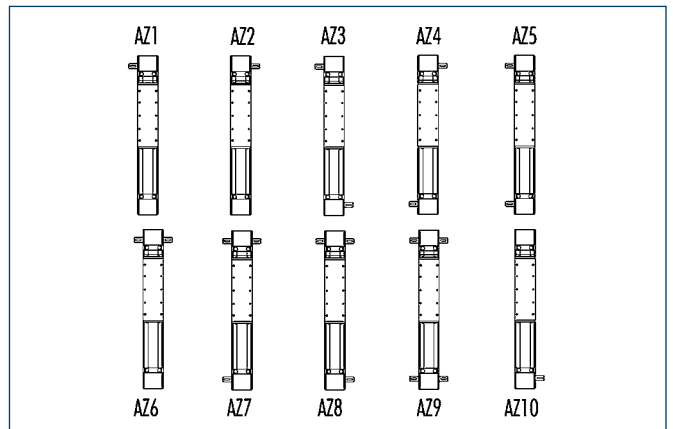

Depending on the axis application, the drive shaft seat may need to be defined in the order text. Particularly with axis combinations and mechanical synchronization, multiple drive shafts - some of them continuous shafts - are required.



More detailed information on pedestal bearings, connection shafts and bevel gears can be found in the "OPTIONS for System HSB" section of the catalog.