

Advantages of roller guide

High maximum moments
due to optimum force transmission to the profile

Long stroke lengths
can be achieved with no problems

Life-time lubricated rollers
for easy maintenance use

Smooth, low-noise running

Advantages of profiled rail guide

High load bearing capacity

Long lifetime

High precision

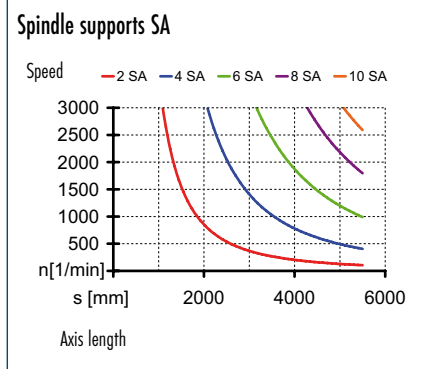

Loads and load torques

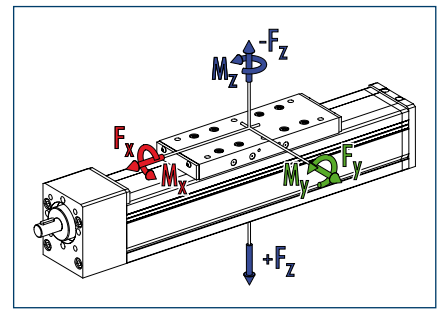

Load	SRS dynamic	SSS dynamic
F_x^{**} [N]	6000	6000
F_y [N]	2500	2500
F_z [N]	5000	6000
$-F_z$ [N]	3000	4000
Load torques	SRS dynamic	SSS dynamic
M_x [Nm]	350	500
M_y [Nm]	700 (900)	1000 (1400)
M_z [Nm]	700 (900)	1000 (1400)
M_{Amax} [Nm]	5.8 (p=5)	6.3 (p=5)
	10.5 (p=10)	11.0 (p=10)
	24.9 (p=25)	25.4 (p=25)
	48.7 (p=50)	49.2 (p=50)

** Depends on speed and pitch n_{max}
KGT = 3000 rpm; TGT = 1500 rpm
① Values in brackets relate to the long slide.

Technical data

Designation	B 140-SRS	B 140-SSS
Max. travel speed	[m/s] 2.5	2.5
Repeat accuracy	[mm] ± 0.03	± 0.03
Max. acceleration	[m/s ²] 20	20
Idle torque	[Nm] 1.0	1.5
Maximum stroke	[mm] 4920	4920
Max. total length	[mm] 5400	5400
Moment of inertia	[kgm ²] 0.000225	0.000225
Drive element	Ball screw spindle drive	Ball screw spindle drive
Max. spindle speed	[rpm] 3000	3000
Diameter	[mm] 25	25
Pitch	[mm] 5 / 10 / 25 / 50	5 / 10 / 25 / 50
Drive element	Trapezoidal threaded drive	Trapezoidal threaded drive
Max. spindle speed	[rpm] 1500	1500
Diameter	[mm] 24	24
Pitch	[mm] 5 / 10	5 / 10
Weights		
Basic without travel	[kg] 14.0	15.0
Travel per 100 mm	[kg] 1.4	1.9
Slide plate 320 mm	[kg] 6.2	7.0
Slide plate 500 mm	[kg] 9.7	10.9

Main views

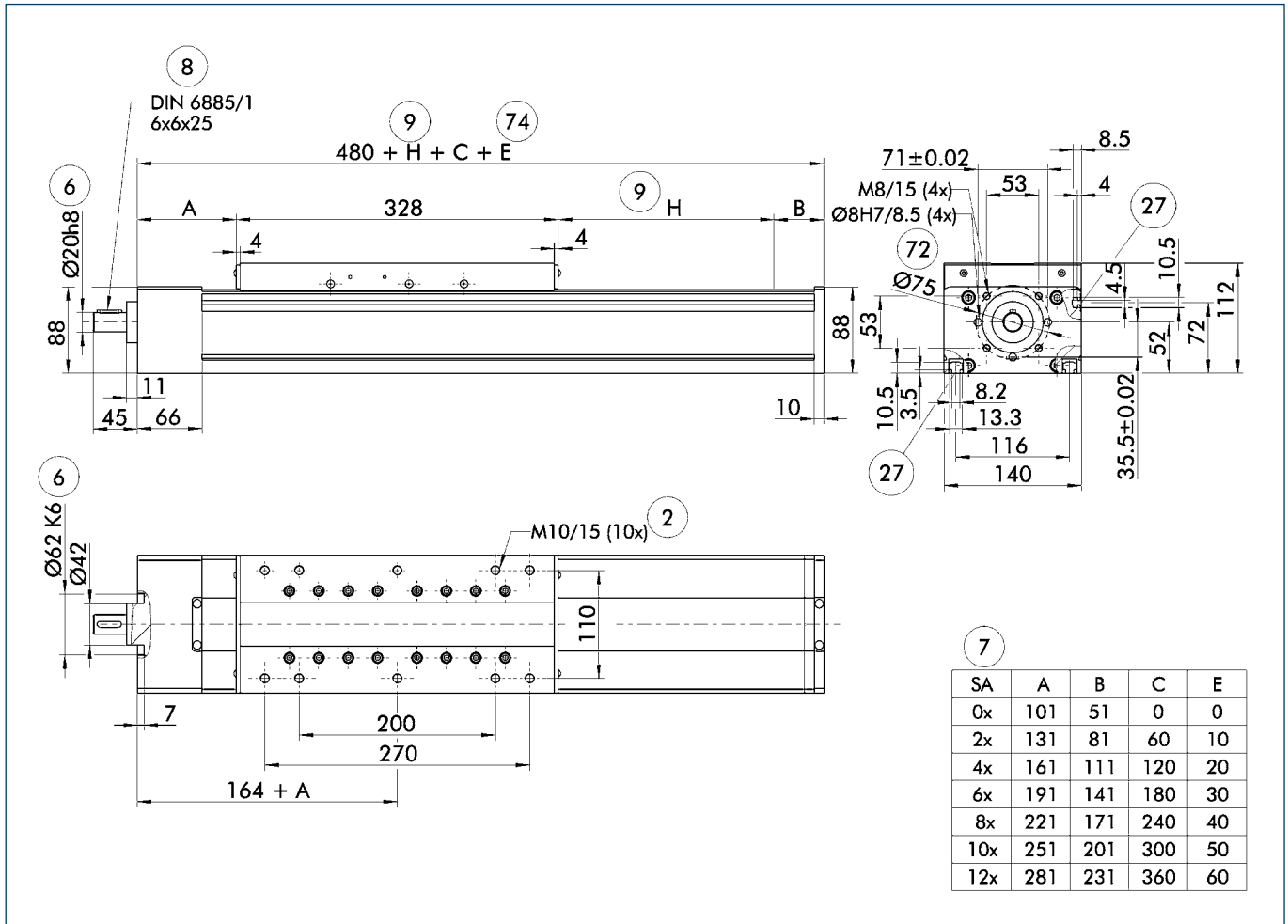

- ② Assembly connection
- ⑥ Drive connection
- ⑦ Number of spindle supports
- ⑧ Feather key DIN 6885
- ⑨ Useful stroke
- ⑳ Mounting groove for T-nuts
- ㉑ Bolt pitch circle

- ㉒ E for spindle supports with insulated noise emissions

Long slide

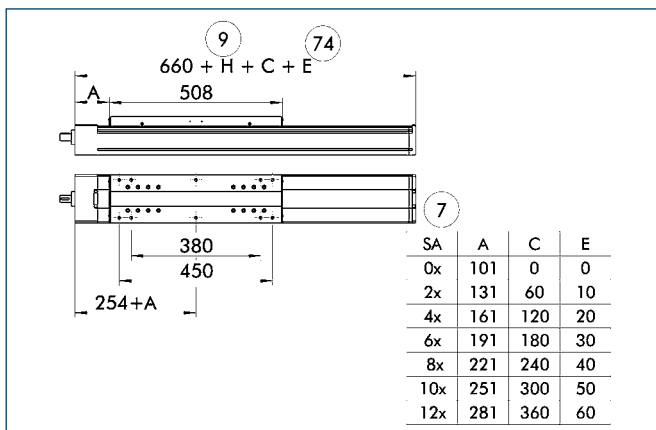

- ⑦ Number of spindle supports
- ⑨ Useful stroke

- ㉒ E for spindle supports with insulated noise emissions

B 140-SRS/-SSS

Linear Axes • Ball Screw Drive

Profile SRS/SSS

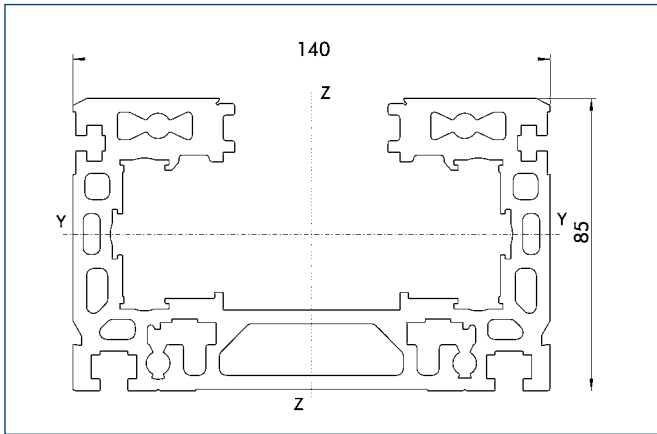

Specific mass	[kg/m]	10.68
Planar dimension	[mm ²]	3955
Planar moment of inertia I _y	[mm ⁴]	3159202
Planar moment of inertia I _z	[mm ⁴]	9975915
Load torque W _y	[mm ³]	69334
Load torque W _z	[mm ³]	184852

Mounting

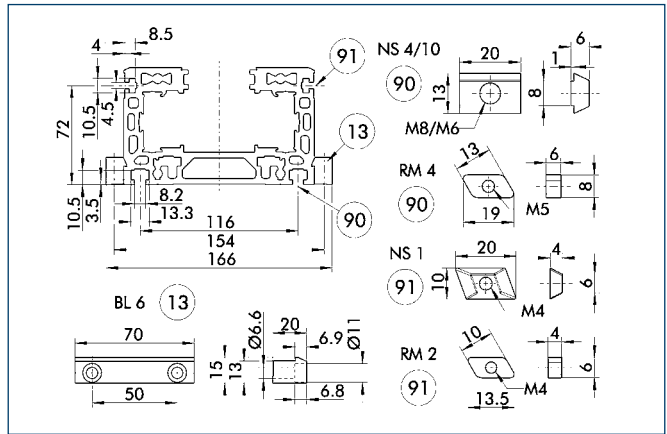

- ⑬ Mounting strip
- ⑨① T-nut on base side
- ⑨① Side T-nut

The profile can be secured either using T-nuts or mounting strips.

Designation	Order designation	ID no.
T-nut	NS1	0331404
T-nut	NS4	0331407
T-nut	NS10	0331422
T-nut	RM2	0331425
T-nut	RM4	0331426
Mounting strip	BL6	0331428

Motor flange schematic diagram

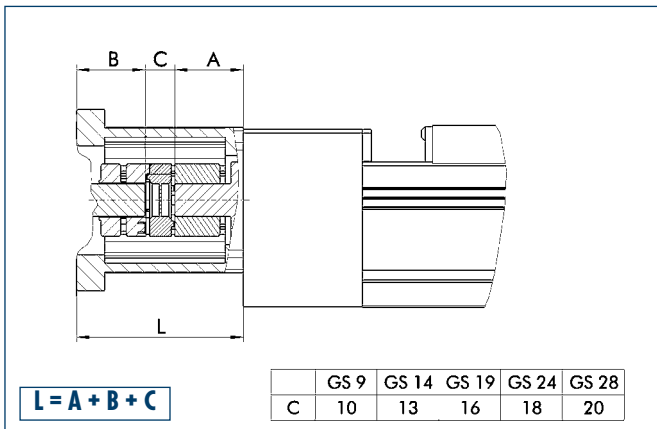

The table shows the relevant dimension **C** of the standard couplings. For dimension **A** refer to drive journal connection dimensions, for dimension **B** refer to corresponding motor dimension sheet, dimension **L** may differ in individual cases.

Different drive solutions can be attached to our axes. SCHUNK can supply you with the right motor flange and coupling for your drive.

① Because of the different thermal behavior of motors, we recommend that the drive solution is tested by the motor manufacturer.

Angle gear schematic diagram

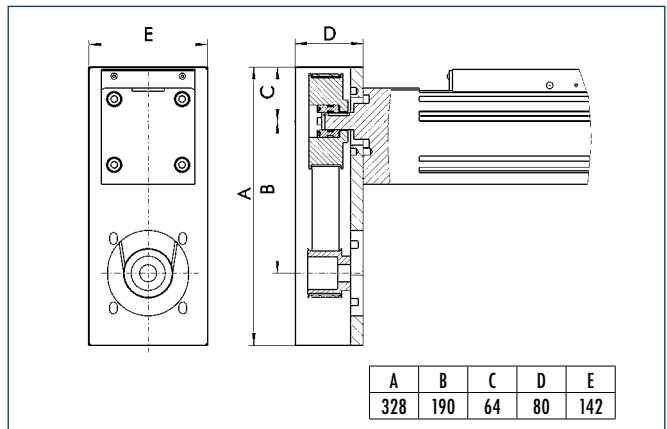

Possible transmission ratios: $i = 1 : 1$, $i = 2 : 1$, $i = 3 : 1$
 Caution: Dimension C can change at $i \neq 1:1$ or with smooth motor shafts (without feather key).
 Even in tight conditions, different drive solutions can be attached. SCHUNK can provide you with the right angle gear for your drive.

① Because of the different thermal behavior of motors, we recommend that the drive solution is tested by the motor manufacturer.

Limit switch position

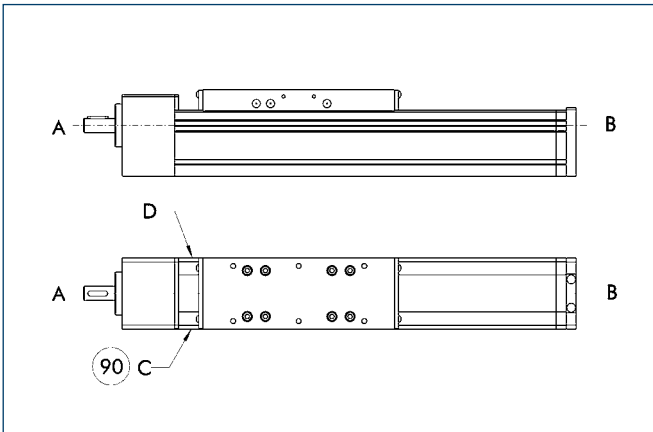

90 Limit switch standard position

Two E02 switches are used as limit switches and an RS2 as the reference switch as standard.

ⓘ The positions and dimensions of limit switches, switching lugs, and mounting components may vary depending on the application and the selected limit switches. Please contact us for assistance.

Limit switch selection

Designation	Order designation	ID no.
Inductive limit switch, opener, 2 m cable	E02	0331410
Inductive limit switch, opener, 10 m cable	E010	0331412
Inductive limit switch, closer, 2 m cable	ES2	0331411
Inductive limit switch, closer, 10 m cable	ES10	0331413
Mechanical limit switch (Siemens), opener	EMS	0331414
Mechanical limit switch (Balluff), opener	EMB	0331415

Lubrication connections

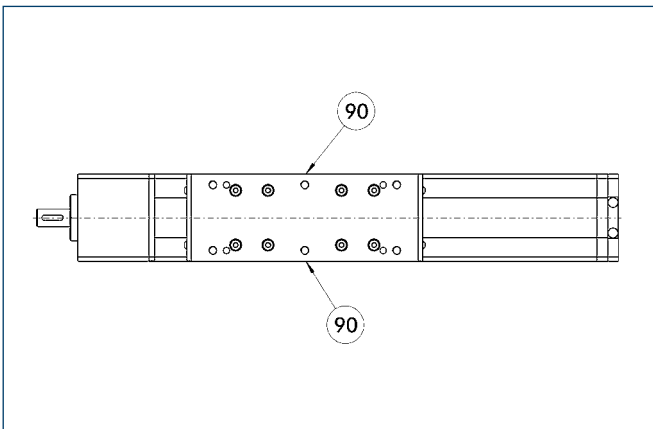

90 Standard lubrication connection

Standard connection

Lubrication nipple M8x1

If the lubrication connection has a different seat, this must be defined in the order text.

More detailed information on pedestal bearings, connection shafts and bevel gears can be found in the "OPTIONS for System HSB" section of the catalog.