

### Advantages of profiled rail guide

High load bearing capacity

Long lifetime

High precision

### Loads and load torques

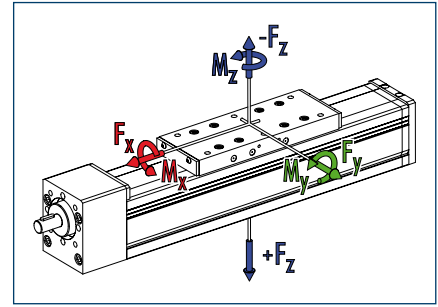

Load	Dynamic
$F_x^{**}$ [N]	12000
$F_y$ [N]	6000
$F_z$ [N]	12000
$-F_z$ [N]	6000
Load torques	Dynamic
$M_x$ [Nm]	1500
$M_y$ [Nm]	3000 (4000)
$M_z$ [Nm]	1500 (2000)
$M_{Amax}$ [Nm]	12.0 (p=5)
	21.6 (p=10)
	40.7 (p=20)
	78.9 (p=40)

\*\* Depends on speed and pitch  $n_{max}$   
 KGT = 3000 rpm; TGT = 1500 rpm

① Values in brackets relate to the long slide.

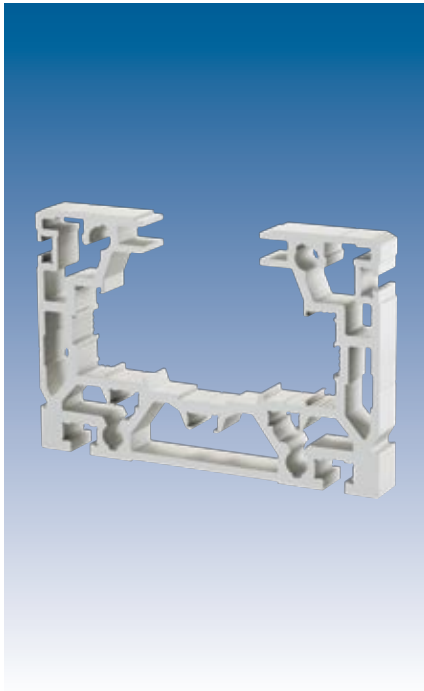

Spindle supports SA

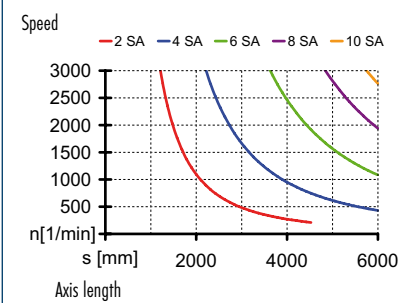

### Technical data

Designation		B 180-SSS
Max. travel speed	[m/s]	2.0
Repeat accuracy	[mm]	± 0.03
Max. acceleration	[m/s <sup>2</sup> ]	20
Idle torque	[Nm]	2.5
Maximum stroke	[mm]	4930
Max. total length	[mm]	5500
Moment of inertia	[kgm <sup>2</sup> ]	0.000645
<b>Drive element</b>		<b>Ball screw spindle drive</b>
Max. spindle speed	[rpm]	3000
Diameter	[mm]	32
Pitch	[mm]	5 / 10 / 20 / 40
<b>Drive element</b>		<b>Trapezoidal threaded drive</b>
Max. spindle speed	[rpm]	1500
Diameter	[mm]	32
Pitch	[mm]	6
<b>Weights</b>		
Basic without travel	[kg]	33.5
Travel per 100 mm	[kg]	2.8
Slide plate 380 mm	[kg]	10.8
Slide plate 600 mm	[kg]	15.5

### Main views

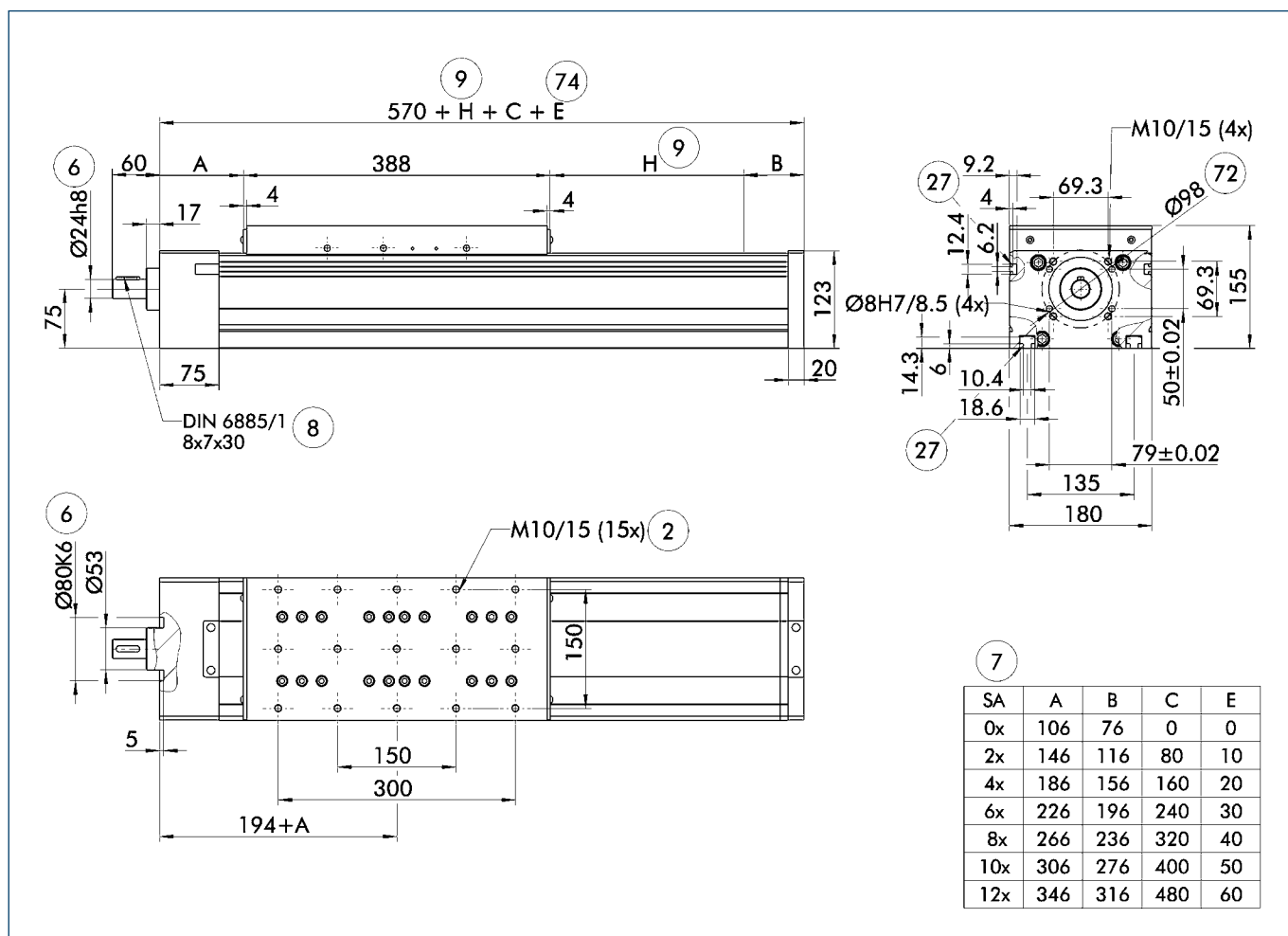

- ② Assembly connection
- ⑥ Drive connection
- ⑦ Number of spindle supports
- ⑧ Feather key DIN 6885
- ⑨ Useful stroke
- ⑳ Mounting groove for T-nuts
- ㉑ Bolt pitch circle

- ㉒ E for spindle supports with insulated noise emissions

### Long slide

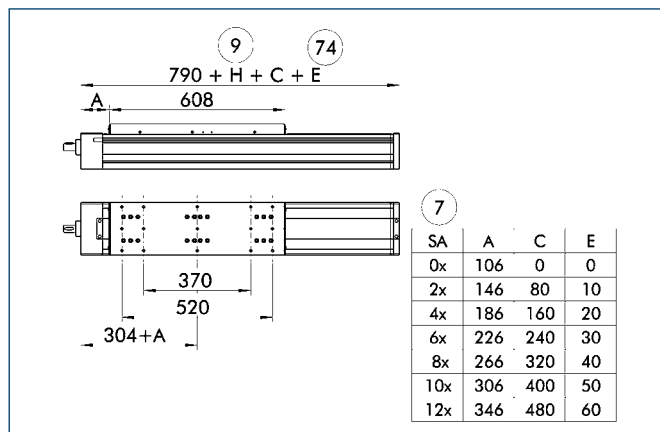

- ⑦ Number of spindle supports
- ⑨ Useful stroke

- ㉒ E for spindle supports with insulated noise emissions

### Profile SSS

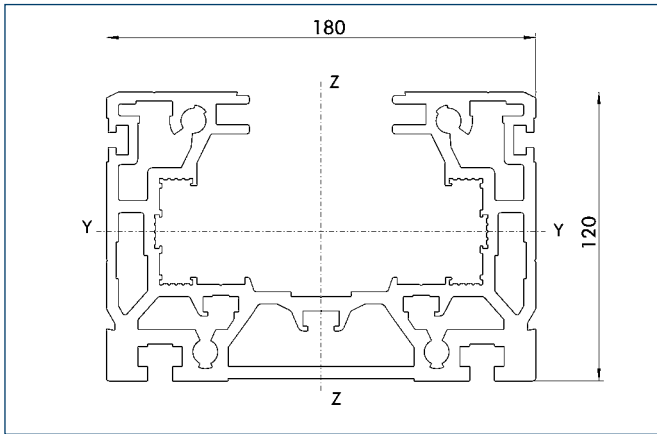

Specific mass	[kg/m]	15.49
Planar dimension	[mm <sup>2</sup> ]	5736
Planar moment of inertia I <sub>y</sub>	[mm <sup>4</sup> ]	9236448
Planar moment of inertia I <sub>z</sub>	[mm <sup>4</sup> ]	23586987
Load torque W <sub>y</sub>	[mm <sup>3</sup> ]	134968
Load torque W <sub>z</sub>	[mm <sup>3</sup> ]	261545

### Mounting

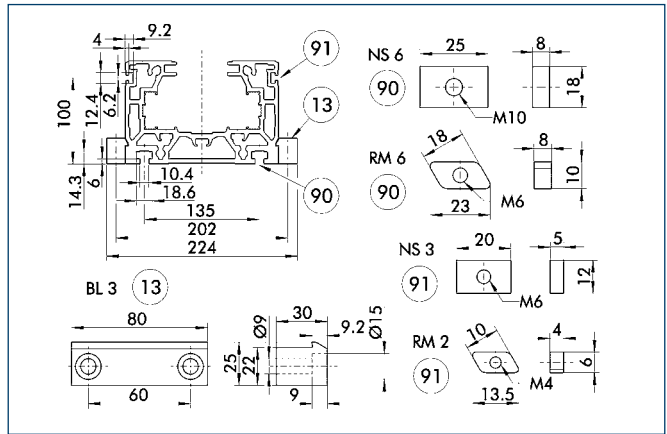

- ⑬ Mounting strip
- ⑨⑩ T-nut on base side
- ⑨① Side T-nut

The profile can be secured either using T-nuts or mounting strips.

Designation	Order designation	ID no.
T-nut	NS3	0331406
T-nut	NS6	0331409
T-nut	RM2	0331425
T-nut	RM6	0331427
Mounting strip	BL3	0331402

### Motor flange schematic diagram

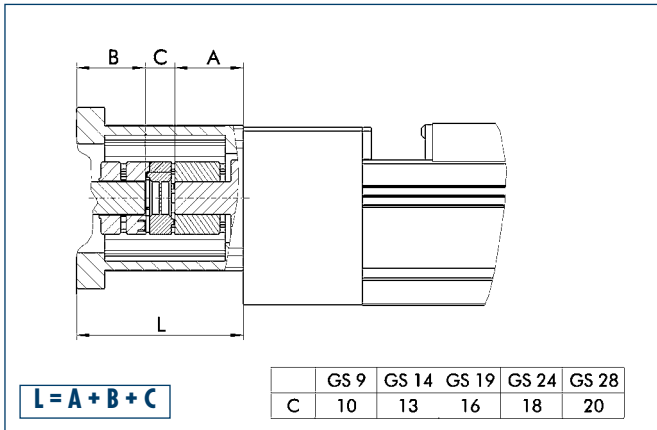

The table shows the relevant dimension **C** of the standard couplings. For dimension **A** refer to drive journal connection dimensions, for dimension **B** refer to corresponding motor dimension sheet, dimension **L** may differ in individual cases. Different drive solutions can be attached to our axes. SCHUNK can supply you with the right motor flange and coupling for your drive.

① Because of the different thermal behavior of motors, we recommend that the drive solution is tested by the motor manufacturer.

### Angle gear schematic diagram

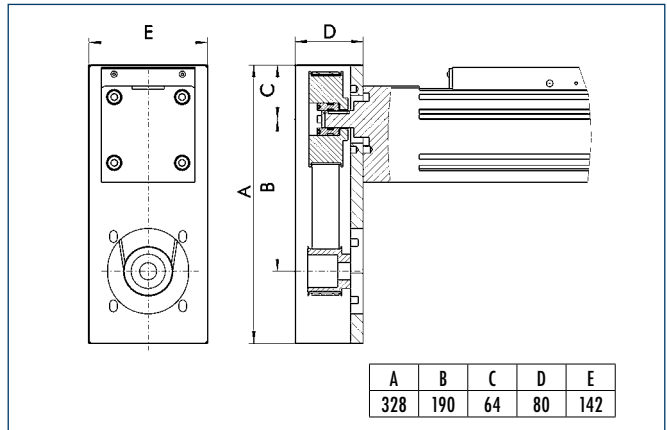

Possible transmission ratios:  $i = 1 : 1$ ,  $i = 2 : 1$ ,  $i = 3 : 1$   
 Caution: Dimension C can change at  $i \neq 1:1$  or with smooth motor shafts (without feather key).  
 Even in tight conditions, different drive solutions can be attached. SCHUNK can provide you with the right angle gear for your drive.

① Because of the different thermal behavior of motors, we recommend that the drive solution is tested by the motor manufacturer.

### Limit switch position

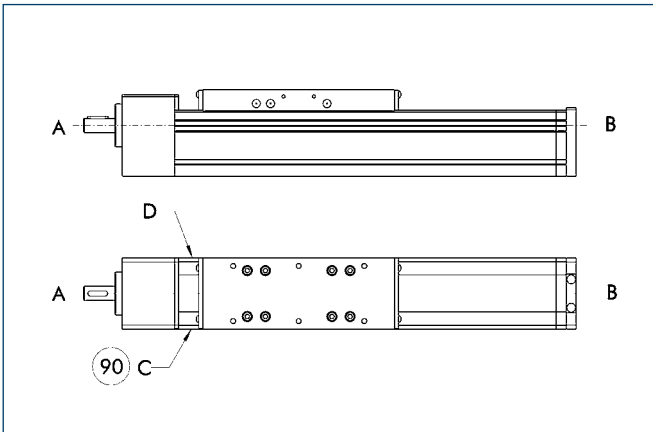

90 Limit switch standard position

Two E02 switches are used as limit switches and an RS2 as the reference switch as standard.

ⓘ The positions and dimensions of limit switches, switching lugs, and mounting components may vary depending on the application and the selected limit switches. Please contact us for assistance.

### Limit switch selection

Designation	Order designation	ID no.
Inductive limit switch, opener, 2 m cable	E02	0331410
Inductive limit switch, opener, 10 m cable	E010	0331412
Inductive limit switch, closer, 2 m cable	ES2	0331411
Inductive limit switch, closer, 10 m cable	ES10	0331413
Mechanical limit switch (Siemens), opener	EMS	0331414
Mechanical limit switch (Balluff), opener	EMB	0331415

### Lubrication connections

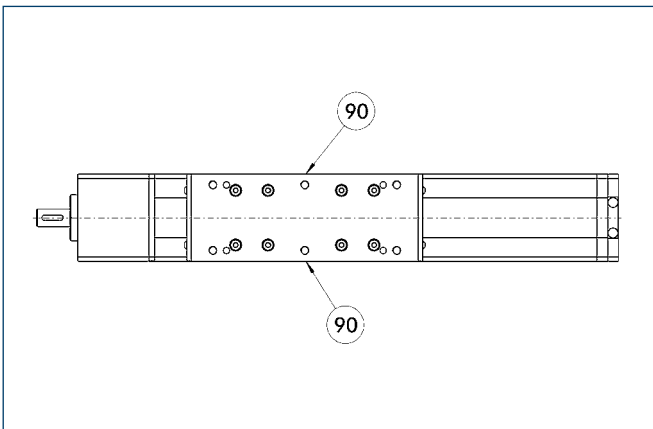

90 Standard lubrication connection

#### Standard connection

Lubrication nipple M8x1

If the lubrication connection has a different seat, this must be defined in the order text.

More detailed information on pedestal bearings, connection shafts and bevel gears can be found in the "OPTIONS for System HSB" section of the catalog.