

### Advantages of profiled rail guide

- High load bearing capacity
- Long lifetime
- High precision

### Loads and load torques

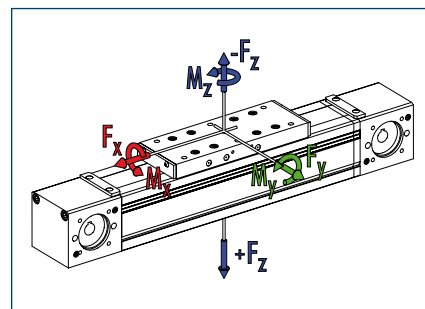

Load		Dynamic
<span style="color: red;">■</span> $F_x^{**}$	[N]	6000
<span style="color: green;">■</span> $F_y$	[N]	6000
<span style="color: blue;">■</span> $F_z$	[N]	12000
<span style="color: blue;">■</span> $-F_z$	[N]	6000
Load torques		Dynamic
<span style="color: red;">■</span> $M_x$	[Nm]	1500
<span style="color: green;">■</span> $M_y$	[Nm]	3000 (4000)
<span style="color: blue;">■</span> $M_z$	[Nm]	1500 (2000)
<span style="color: blue;">■</span> $M_{Amox}$	[Nm]	313.6

\*\* Maximum value = Depending on speed

① Values in brackets relate to the long slide.

### Technical data

Designation		B 180-ZSS
Max. travel speed	[m/s]	5
Repeat accuracy	[mm]	± 0.08
Max. acceleration	[m/s <sup>2</sup> ]	60
Idle torque	[Nm]	8.0
Drive		
Drive element	Toothed belt	75 AT 10
Travel per revolution	[mm]	320
Maximum stroke	[mm]	5500
Max. total length	[mm]	6200
Moment of inertia	[kgm <sup>2</sup> ]	0.056
Weights		
Basic without travel	[kg]	37.7
Travel per 100 mm	[kg]	2.4
Slide plate 380 mm	[kg]	11.2
Slide plate 600 mm	[kg]	15.7



### Profile ZSS

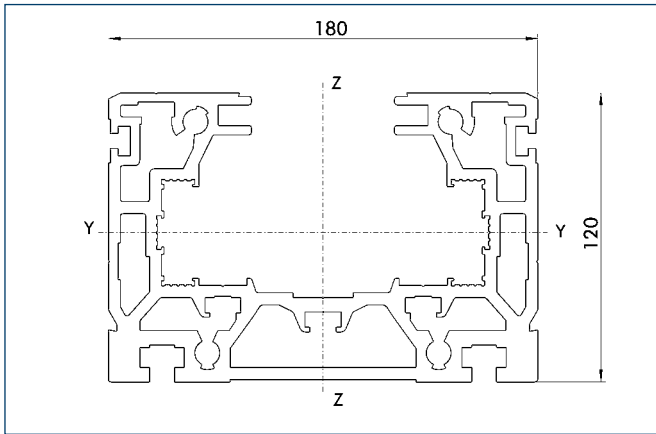

Specific mass	[kg/m]	15.49
Planar dimension	[mm <sup>2</sup> ]	5736
Planar moment of inertia I <sub>y</sub>	[mm <sup>4</sup> ]	9236448
Planar moment of inertia I <sub>z</sub>	[mm <sup>4</sup> ]	23586987
Load torque W <sub>y</sub>	[mm <sup>3</sup> ]	134968
Load torque W <sub>z</sub>	[mm <sup>3</sup> ]	261545

### Mounting

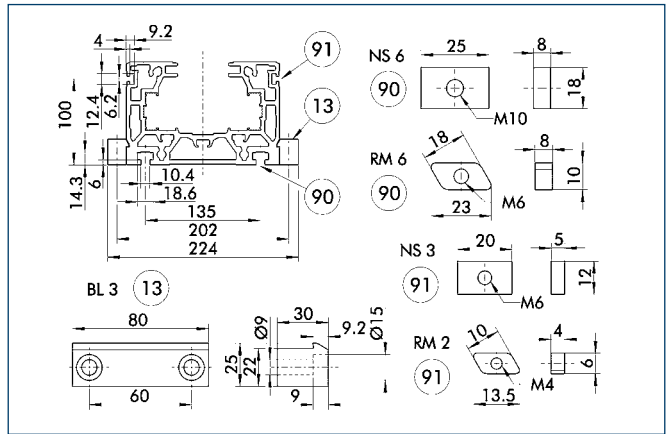

- ⑬ Mounting strip
- ⑨⑩ T-nut on base side
- ⑨① Side T-nut

The profile can be secured either using T-nuts or mounting strips.

Designation	Order designation	ID no.
T-nut	NS3	0331406
T-nut	NS6	0331409
T-nut	RM2	0331425
T-nut	RM6	0331427
Mounting strip	BL3	0331402

### Motor flange schematic diagram

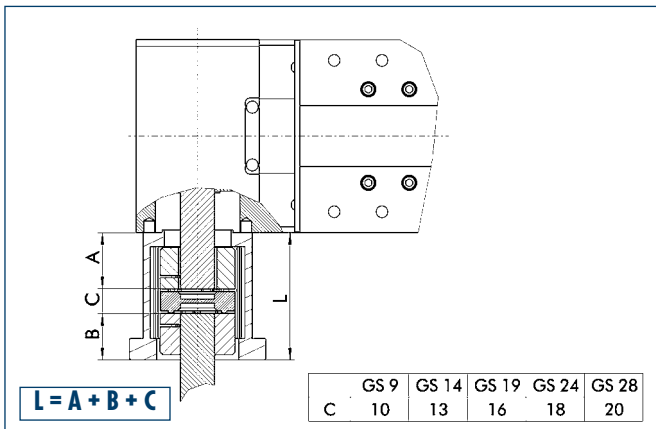

The table shows the relevant dimension **C** of the standard couplings. For dimension **A** refer to drive journal connection dimensions, for dimension **B** refer to corresponding motor dimension sheet, dimension **L** may differ in individual cases.

Different drive solutions can be attached to our axes. SCHUNK can supply you with the right motor flange and coupling for your drive.

- ① Because of the different thermal behavior of motors, we recommend that the drive solution is tested by the motor manufacturer.

### Limit switch position

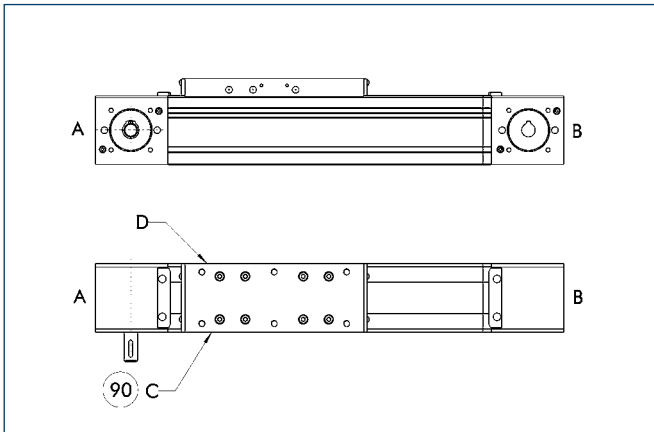

90 Limit switch standard position

Two E02 switches are used as limit switches and an RS2 as the reference switch as standard.

① The positions and dimensions of limit switches, switching lugs, and mounting components may vary depending on the application and the selected limit switches. Please contact us for assistance.

### Limit switch selection

Designation	Order designation	ID no.
Inductive limit switch, opener, 2 m cable	E02	0331410
Inductive limit switch, opener, 10 m cable	E010	0331412
Inductive limit switch, closer, 2 m cable	ES2	0331411
Inductive limit switch, closer, 10 m cable	ES10	0331413
Mechanical limit switch (Siemens), opener	EMS	0331414
Mechanical limit switch (Balluff), opener	EMB	0331415

### Lubrication connections

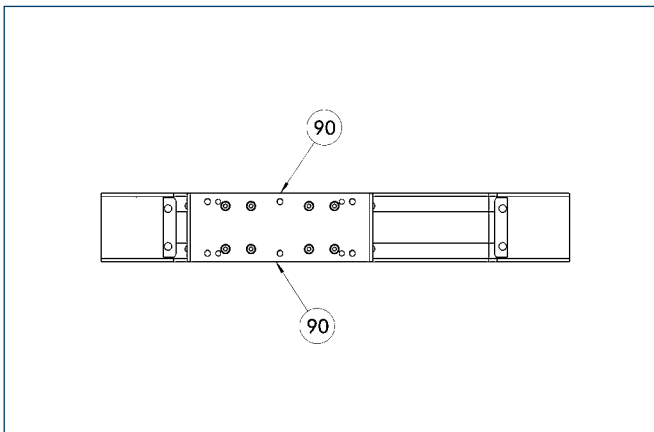

90 Standard lubrication connection

#### Standard connection

Lubrication nipple M8x1

If the lubrication connection has a different seat, this must be defined in the order text.

### Drive shafts

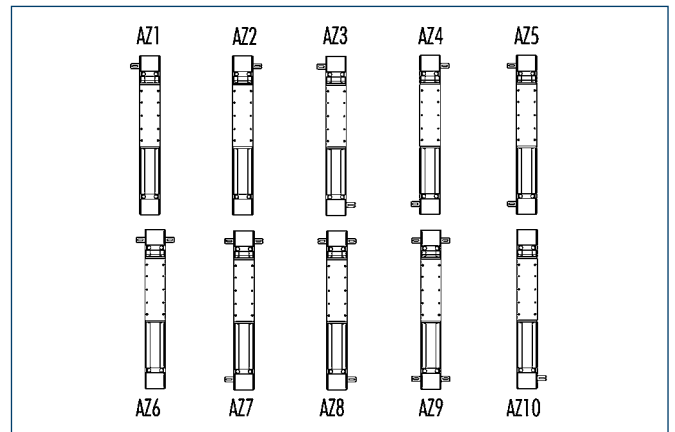

Depending on the axis application, the drive shaft seat may need to be defined in the order text. Particularly with axis combinations and mechanical synchronization, multiple drive shafts - some of them continuous shafts - are required.



More detailed information on pedestal bearings, connection shafts and bevel gears can be found in the "OPTIONS for System HSB" section of the catalog.