

Advantages of profiled rail guide

- High load bearing capacity
- Long lifetime
- High precision

Loads and load torques

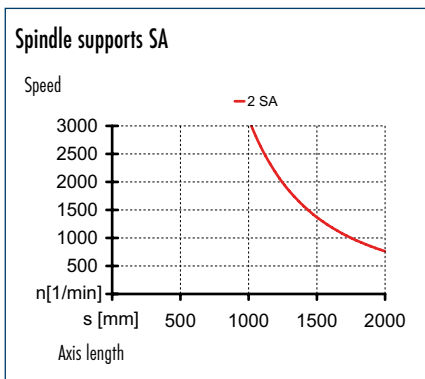
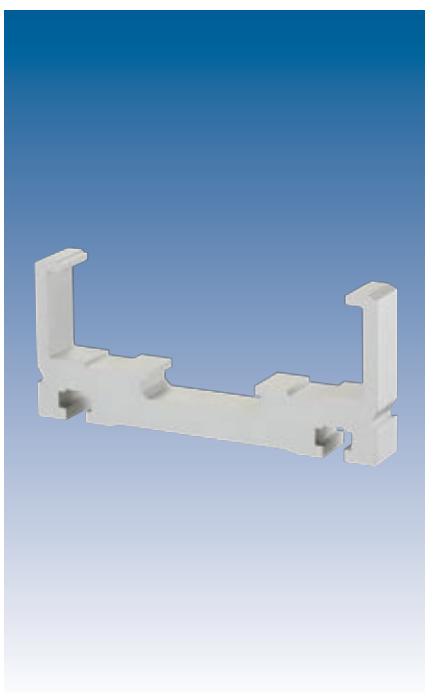
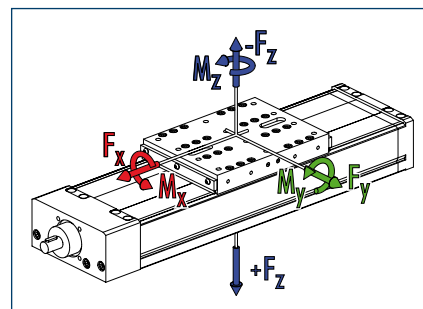

Load	Dynamic
F_x^{**} [N]	6000
F_y [N]	2500
F_z [N]	5000
$-F_z$ [N]	3000
Load torques	
M_x [Nm]	800
M_y [Nm]	1000 (1600)
M_z [Nm]	1000 (1600)
M_{Amax} [Nm]	5.9 (p=5)
	10.6 (p=10)
	25.0 (p=25)
	48.8 (p=50)

** Depends on speed and pitch n_{max}
 KGT = 3000 rpm; TGT = 1500 rpm

① Values in brackets relate to the long slide.

Technical data

Designation		D 145-SSS
Max. travel speed	[m/s]	2.5
Repeat accuracy	[mm]	± 0.03
Max. acceleration	[m/s ²]	20
Idle torque	[Nm]	1.1
Maximum stroke	[mm]	1700
Max. total length	[mm]	2000
Moment of inertia	[kgm ²]	0.000225
Drive element		Ball screw spindle drive
Max. spindle speed	[rpm]	3000
Diameter	[mm]	25
Pitch	[mm]	5 / 10 / 25 / 50
Drive element		Trapezoidal threaded drive
Max. spindle speed	[rpm]	1500
Diameter	[mm]	24
Pitch	[mm]	5 / 10
Weights		
Basic without travel	[kg]	13.5
Travel per 100 mm	[kg]	1.5
Slide plate 180 mm	[kg]	5.8
Slide plate 300 mm	[kg]	9.7

Main views

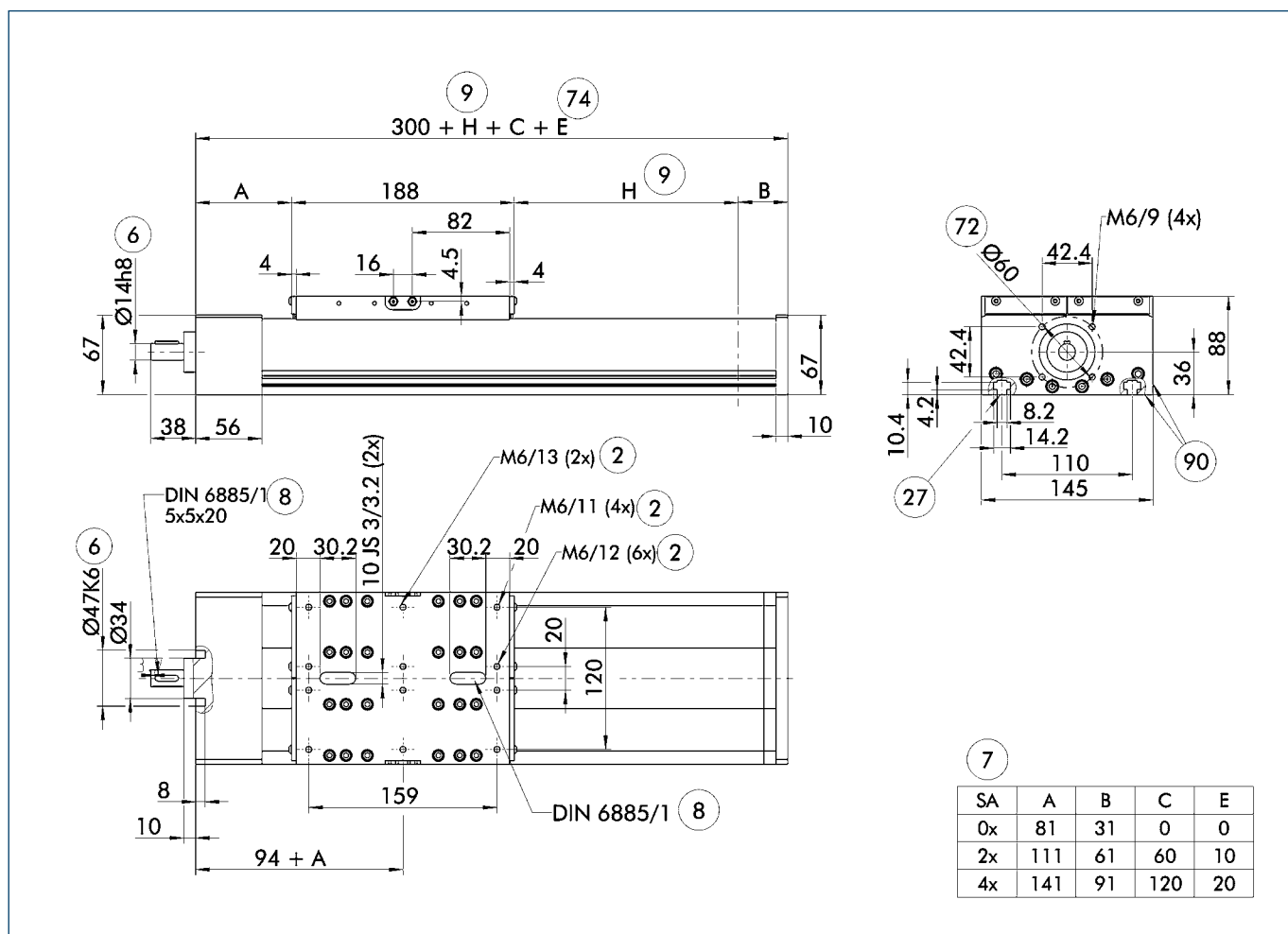

- ② Assembly connection
- ⑥ Drive connection
- ⑦ Number of spindle supports
- ⑧ Feather key DIN 6885
- ⑨ Useful stroke
- ⑳ Mounting groove for T-nuts
- ㉑ Bolt pitch circle

- ㉒ E for spindle supports with insulated noise emissions
- ㉓ Stop angle for alignment of axis

Long slide

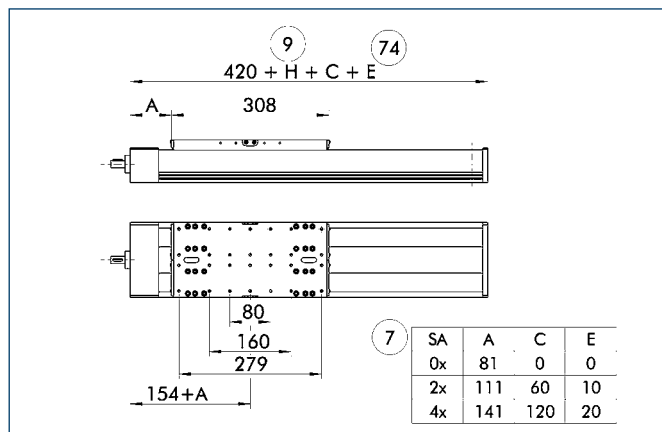

- ⑦ Number of spindle supports
- ⑨ Useful stroke

- ㉒ E for spindle supports with insulated noise emissions

Profile SSS

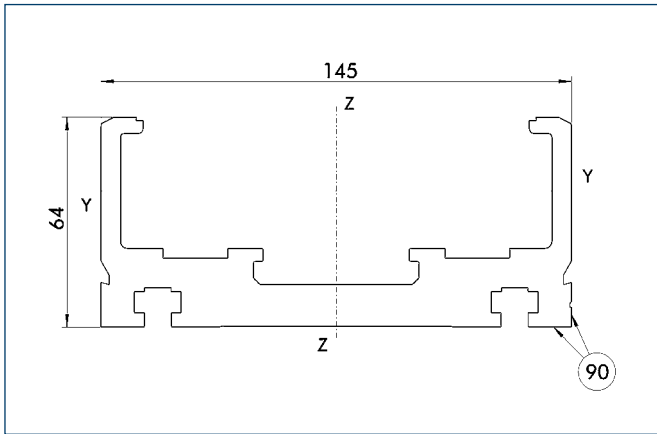

90 Stop angle standard side

Specific mass	[kg/m]	8.54
Planar dimension	[mm ²]	3163
Planar moment of inertia I _y	[mm ⁴]	747431
Planar moment of inertia I _z	[mm ⁴]	7649112
Load torque W _y	[mm ³]	15814
Load torque W _z	[mm ³]	104251

Motor flange schematic diagram

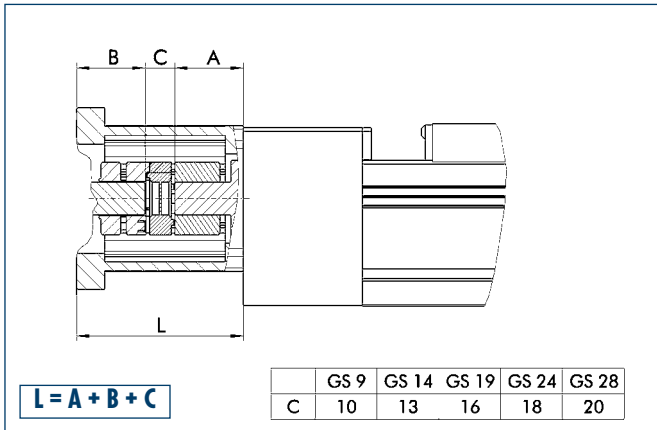

The table shows the relevant dimension **C** of the standard couplings. For dimension **A** refer to drive journal connection dimensions, for dimension **B** refer to corresponding motor dimension sheet, dimension **L** may differ in individual cases. Different drive solutions can be attached to our axes. SCHUNK can supply you with the right motor flange and coupling for your drive.

① Because of the different thermal behavior of motors, we recommend that the drive solution is tested by the motor manufacturer.

Mounting

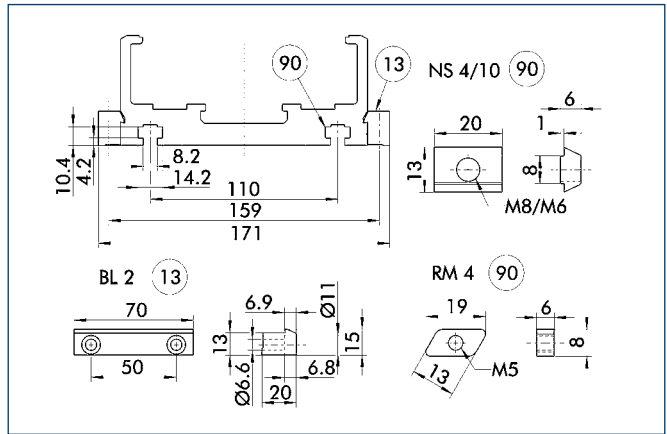

13 Mounting strip

90 T-nut on base side

The profile can be secured either using T-nuts or mounting strips.

Designation	Order designation	ID no.
T-nut	NS4	0331407
T-nut	NS10	0331422
T-nut	RM4	0331426
Mounting strip	BL2	0331401

Angle gear schematic diagram

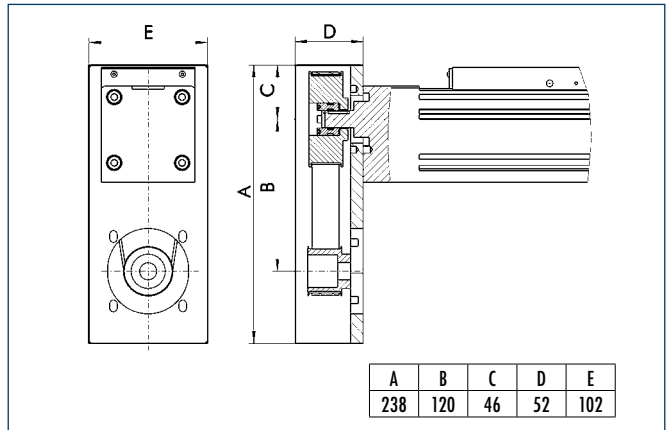

Possible transmission ratios: $i = 1 : 1$, $i = 2 : 1$, $i = 3 : 1$

Caution: Dimension C can change at $i \neq 1:1$ or with smooth motor shafts (without feather key).

Even in tight conditions, different drive solutions can be attached. SCHUNK can provide you with the right angle gear for your drive.

① Because of the different thermal behavior of motors, we recommend that the drive solution is tested by the motor manufacturer.

Limit switch position

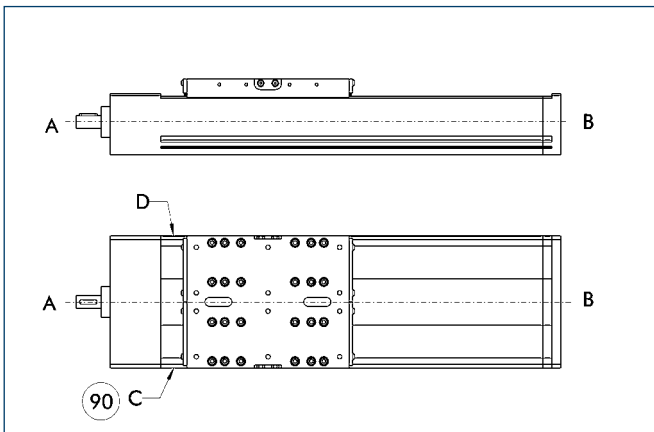

90 Limit switch standard position

Two E02 switches are used as limit switches and an RS2 as the reference switch as standard.

- ① The positions and dimensions of limit switches, switching lugs, and mounting components may vary depending on the application and the selected limit switches. Please contact us for assistance.

Limit switch selection

Designation	Order designation	ID no.
Inductive limit switch, opener, 2 m cable	E02	0331410
Inductive limit switch, opener, 10 m cable	E010	0331412
Inductive limit switch, closer, 2 m cable	ES2	0331411
Inductive limit switch, closer, 10 m cable	ES10	0331413
Mechanical limit switch (Siemens), opener	EMS	0331414
Mechanical limit switch (Balluff), opener	EMB	0331415

Lubrication connections

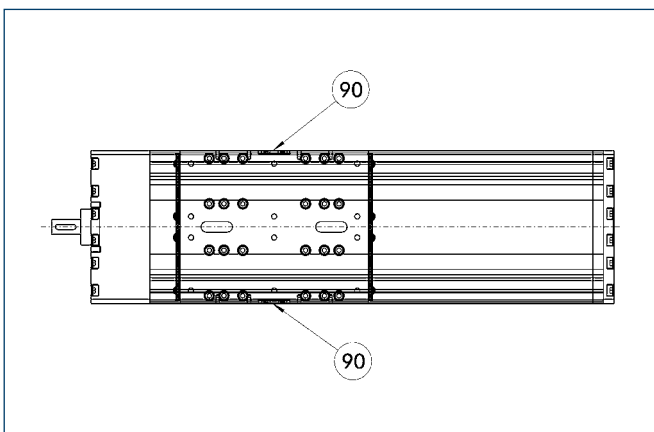

90 Standard lubrication connection

Standard connection

Lubrication nipple M8x1

If the lubrication connection has a different seat, this must be defined in the order text.

 More detailed information on pedestal bearings, connection shafts and bevel gears can be found in the "OPTIONS for System HSB" section of the catalog.