

3-Finger Centric Gripper Type HZN, hydraulic

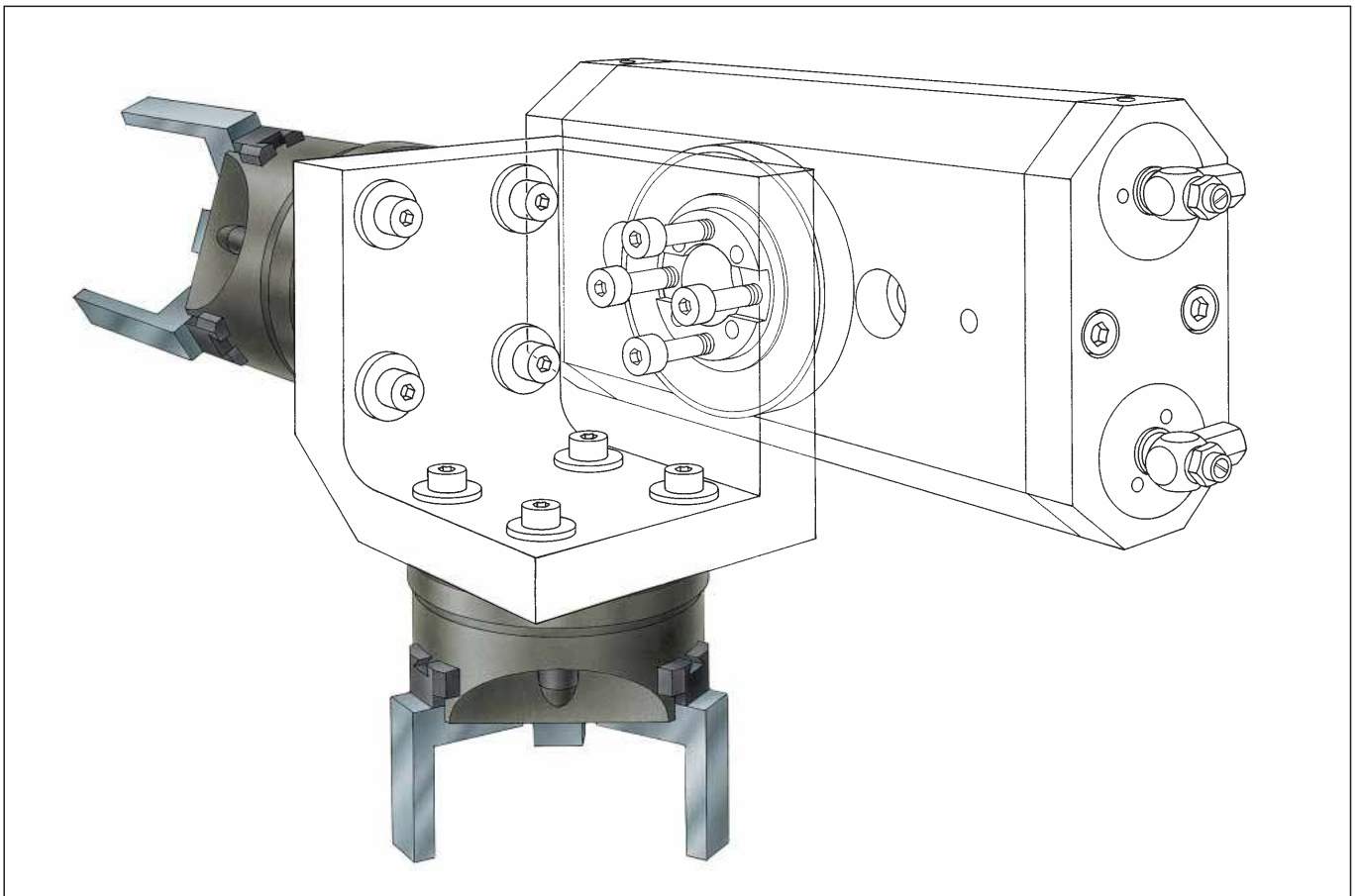



Figure with steel top jaws

Benefits

- Very compact by virtue of the fact that the drive is integrated into the housing
- Very low weight due to the use of high-strength aluminium
- High gripping force through wedge and hook principle
- 4 sizes
- Good guidance properties thanks to flat guides
- Centric and parallel gripping movement due to positively-guided base jaws
- For O.D. and I.D. gripping
- Oil connection on 2 sides and gripper fastening on 1 side
- Stroke monitoring: 2 positions via proximity switches and 5 via Hall sensors

Technical data

Medium:

Hydraulic oil, filtered (10 µm) viscosity 46 mm²/s at 40 °C according to ISO VG, max. temperature 60 °C

Operating pressure range:

from 30 - 60 bar

Repeat accuracy:

HZN 80 and HZN 100 approx. 0.05 mm, HZN 125 and HZN 160 approx. 0.1 mm

Pressure connections:

either on the sides or the base.

It is essential that you use a flow control valve set to 2 l/min.

Maintenance:

permanently lubricated, re-lubrication recommended after 1.5 million strokes

Method of functioning:

positively guided wedge hook system

Material:

housing is made from high-strength, hard-coated aluminium alloy and the functional components are from hardened steel

Type of gripping:

centric

Installation position:

application-dependent

Operating temperature:

from 5 °C - 60 °C

Stroke control:

possible via proximity switches or flexible position sensors



HZN 80

HZN 100

HZN 125

HZN 160

Maximum permissible forces and torques at the gripping fingers *

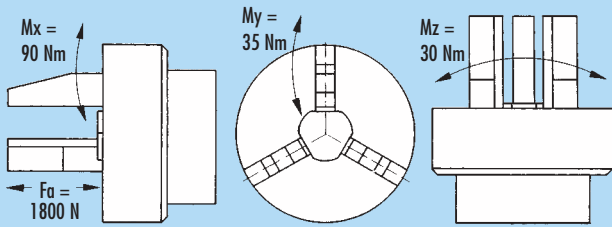

Gripping force in relation to the finger length

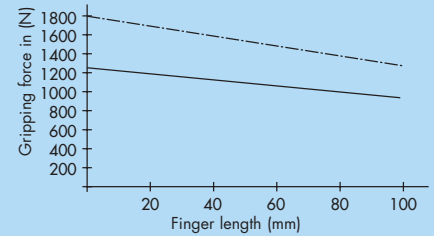

*which may occur in addition to the gripping force

Dimensions for HZN 80

● = Oil connection

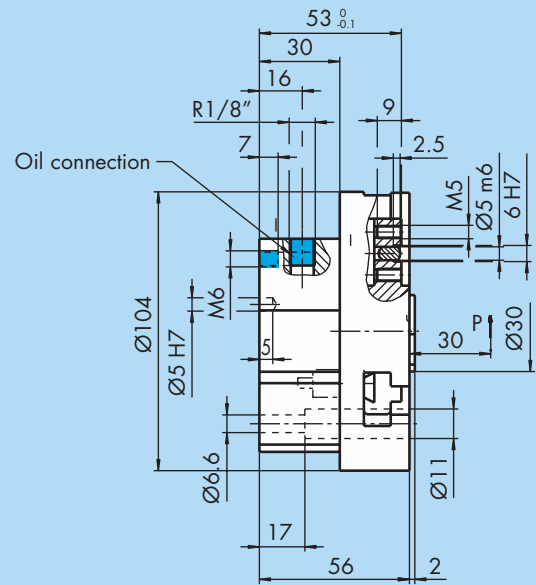
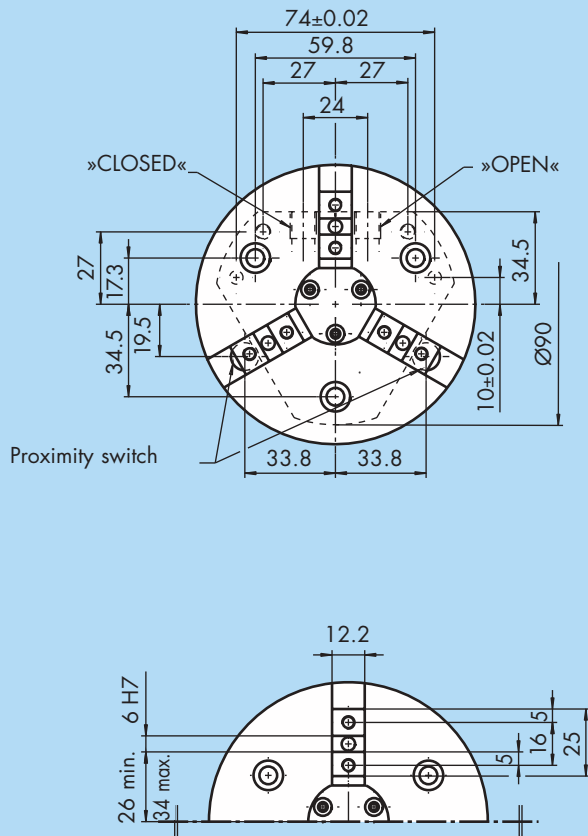

Hose-free direct connection

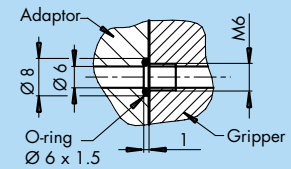

Gripping force safety device with spring only for O.D. gripping.

Can only be supplied on order with gripper.

Operating pressure range: min. 35 bar, max. 60 bar.

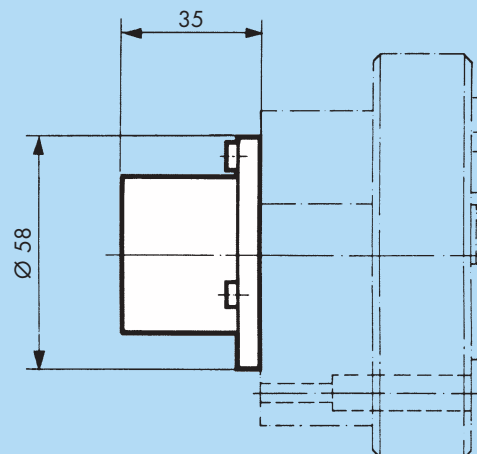

3-Finger Centric Gripper HZN 80 and HZN 80 AS with integrated maintenance of gripping force

Type	HZN 80	HZN 80 AS
ID. no.	300 331	300 335*****
Stroke per jaw	8 mm	8 mm
Operating pressure max.	60 bar	60 bar
Gripping force at 60 bar*	1230 N	–
Max. workpiece weight** (recommended)	6 kg	6 kg
Oil volume per double stroke	8.5 cm ³	8.5 cm ³
Safety device force spring min.-max	–	340-550 N
Gripping force pressure+spring min.-max.*****	–	1570-1780 N
Closing time only with spring	–	0.2 s
Opening time****	0.2 s	0.2 s
Closing time****	0.3 s	0.2 s
Mass	1.3 kg	2.1 kg
Mass moment of inertia	19 kg cm ²	21 kg cm ²
Repeat accuracy***	0.05 mm	0.05 mm
Max. finger length	80 mm	80 mm

- * Gripping force is the arithmetic sum of the individual forces occurring at the gripper jaws at P
- ** Values at $\mu = 0.1$ and safety factor $v = 2$. The values may be higher in the case of form-fit clamping.
- *** Variation of end positions after 100 consecutive strokes.
- **** Measured at 60 bar and R $\frac{1}{8}$ " connection.
- ***** Id. no. includes gripper and gripping force



HZN 80

HZN 100

HZN 125

HZN 160

Accessories for HZN 80



Inductive proximity switches

In easy-to-assemble version with LED display. For technical details see the »Accessories« catalogue.

Type	ID. no.
INW 80/S*	301 508 altern. 301 408

* S = Closer



Flexible position sensors, FPS

In the HZN 80, it is possible to monitor up to 5 positions via the flexible position sensors, FPS. For a technical description see the »Accessories« catalogue.

Type	ID. no.
FPS-S 13	301 705
FPS-A 5	301 800
AS-HZN 80/100*	301 715

* includes bracket, magnet and mounting screws.

For technical data see the »Accessories« catalogue.



Finger blanks

For technical details see the »Accessories« catalogue.

Type	Material	ID. no.
ABR 80	Aluminium	300 726
SBR 80	Steel	300 735

System modules and further accessories for HZN



Swivel units

Combineable swivel units and heads are featured on Pages 40-47.



Special solutions

We can quickly supply cost-effective custom solutions, customised fingers, attachment plates and complete units to suit your specialised requirements.



Further accessories

For gripper pads to increase friction factors, pressure maintenance valves or distributors for proximity switches, see the »Accessories« catalogue.

Note

Please note that the lifespan of these units can be reduced considerably if they are used in extreme conditions (e.g. where coolant is used or dust from casting or grinding processes is present). We cannot be held responsible in such cases. Solutions do exist for many problems – please contact us to find out more.