

Inductive Proximity Switches

Inductive proximity switches are used to monitor the current position of automation components. They are available from SCHUNK in the versions IN (sensor with 30 cm molded cable and cable connector) or INK (sensor with 2 m long feeder cable and litz wires for wiring).



Function description

With their oscillator coil, inductive proximity switches produce a high-frequency, alternating magnetic field. This field occurs on the active surface of the sensor. If a metal object enters the field, it draws energy from the magnetic field, thereby reducing the oscillation amplitude. This change is detected, and the sensor switches.

Your advantages and benefits

Mounting through bracket

for simple, fast assembly

Version with LED display

for checking the switching state directly at the sensor

Version with connector

for easy, rapid replacement of the extension cable

Ultra-flexible PUR cable

for a long life and resistance to many chemicals

Proximity switch can be installed flush

for minimal interfering contours in the application

Application example

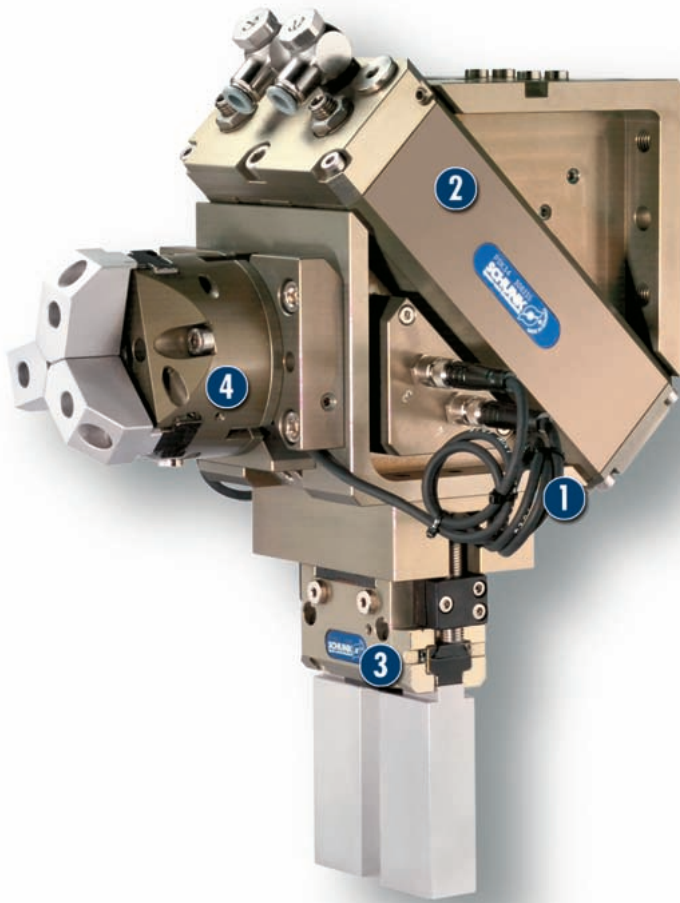

Area of application

For monitoring of gripping and rotary modules, linear modules and robot accessories. Inductive SCHUNK sensors detect metals without contact and are resistant to vibration, dust and humidity.

1 Plug-in IN Sensors

2 PSK Swivel Head

3 PGN 2-Finger Parallel Gripper
with ABR finger blanks

4 PZN 3-Finger Centric Gripper
with workpiece-specific
gripper fingers

General information

Protection class according to DIN 40050

IP 67 when connected

Voltage

10 – 30 V DC, residual ripple < 15 %

Switching method

PNP switching

Warranty

24 months

Notes

SCHUNK gripping, rotary and linear modules and robot accessory components must always be ordered from SCHUNK with the matching sensors, as these are ideally adapted to work together.

If major characteristics such as switching distance, switching function, hysteresis and voltage are largely the same, then proximity switches from other manufacturers may be used instead of inductive proximity switches (IN, INK) from SCHUNK.

However, if proximity switches from other manufacturers are used, SCHUNK cannot guarantee either their function or their functional reliability.

Circuit diagram of closer

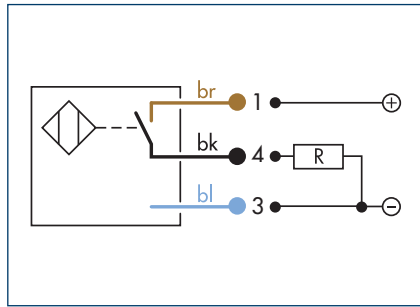

Technical data

Description	ID	IN 5/S-M8	IN 5/S-M12	INK 5/S
		0301469	0301569	0301501
Switching function		Closer	Closer	Closer
Switching distance	[mm]	1.0	1.0	1.0
Hysteresis of nominal switching distance		< 15%	< 15%	< 15%
Switching method		PNP	PNP	PNP
Cable length	[cm]	30.0	30.0	200.0
Cable connector/cable end		M8	M12	Open wire
Type of voltage		DC	DC	DC
Nominal voltage	[V]	24.0	24.0	24.0
Min. voltage	[V]	10.0	10.0	10.0
Max. voltage	[V]	30.0	30.0	30.0
Voltage drop	[V]	1.5	1.5	1.5
Max. power on contact	[A]	0.2	0.2	0.2
Min. ambient temperature	[°C]	-25.0	-25.0	-25.0
Max. ambient temperature	[°C]	70.0	70.0	70.0
Max. switching frequency	[Hz]	1000.0	1000.0	1000.0
IP rating (sensor)		67	67	67
IP rating (connector, plugged in)		67	67	67
LED display on sensor		No	No	No
Cable diameter	[mm]	3.5	3.5	3.5
Min. bending radius (dynamic)	[mm]	35.0	35.0	35.0
Min. bending radius (static)	[mm]	17.5	17.5	17.5
No. of wires		3	3	3
Wire cross section	[mm ²]	0.14	0.14	0.14

IN 5/S sensor

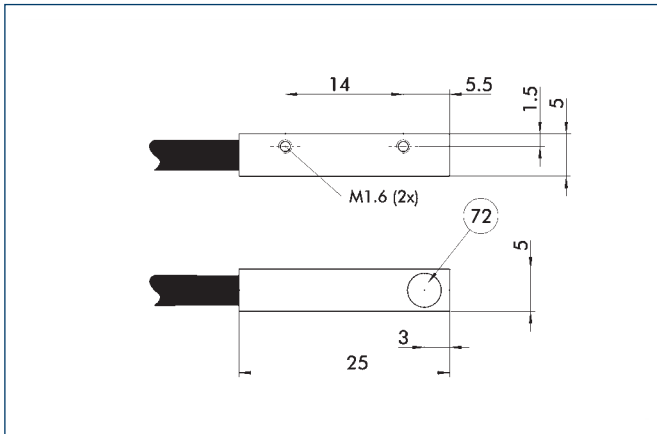

72 Active sensor surface

M8 connector

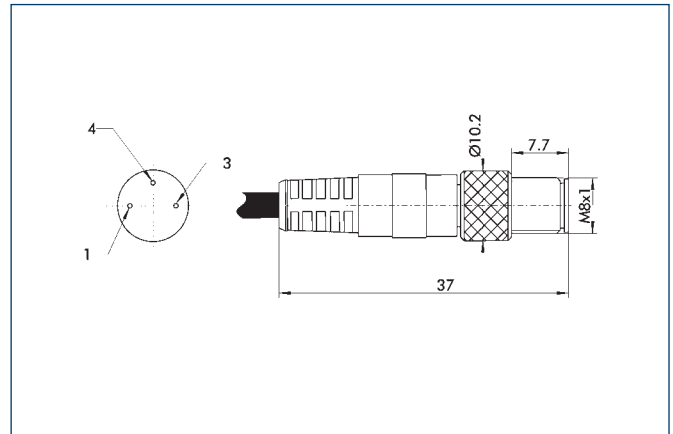

M12 connector

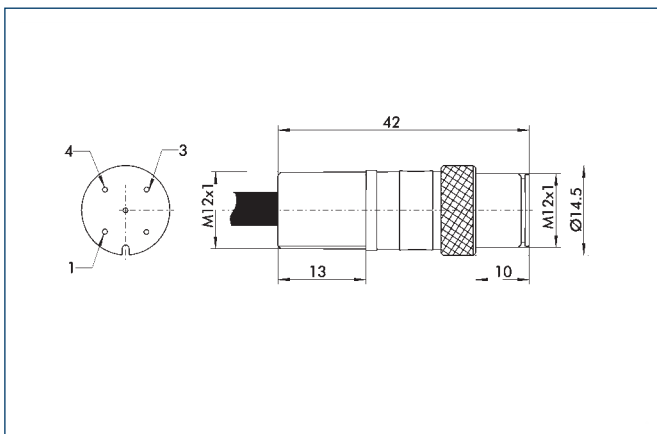

Circuit diagram of closer

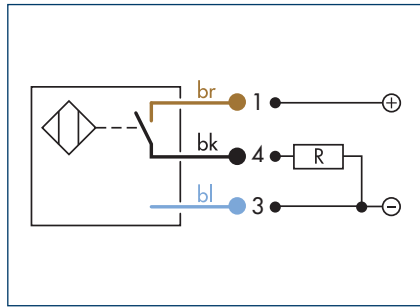

Technical data

Description	ID	IN 8/S-M8	IN 8/S-M12	IN K 8/S
		0301481	0301581	9700052
Switching function		Closer	Closer	Closer
Switching distance	[mm]	0.8	0.8	0.8
Hysteresis of nominal switching distance		< 15%	< 15%	< 15%
Switching method		PNP	PNP	PNP
Cable length	[cm]	30.0	30.0	200.0
Cable connector/cable end		M12	M12	Open wire
Type of voltage		DC	DC	DC
Nominal voltage	[V]	24.0	24.0	24.0
Min. voltage	[V]	10.0	10.0	10.0
Max. voltage	[V]	30.0	30.0	30.0
Voltage drop	[V]	1.5	1.5	1.5
Max. power on contact	[A]	0.2	0.2	0.2
Min. ambient temperature	[°C]	-25.0	-25.0	-25.0
Max. ambient temperature	[°C]	70.0	70.0	70.0
Max. switching frequency	[Hz]	1000.0	1000.0	1000.0
IP rating (sensor)		67	67	67
IP rating (connector, plugged in)		67	67	67
LED display on sensor		No	No	No
Cable diameter	[mm]	3.5	3.5	3.5
Min. bending radius (dynamic)	[mm]	35.0	35.0	35.0
Min. bending radius (static)	[mm]	17.5	17.5	17.5
No. of wires		3	3	3
Wire cross section	[mm ²]	0.14	0.14	0.14

IN 8/S sensor

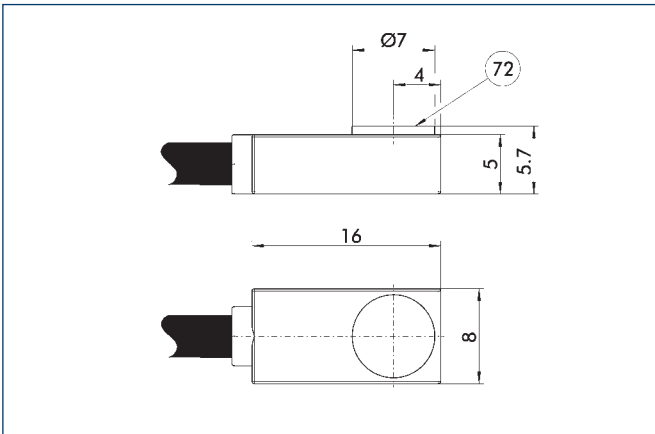

72 Active sensor surface

M8 connector

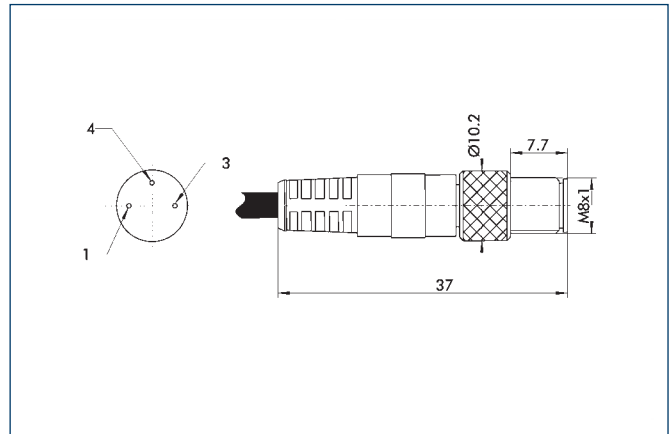

M12 connector

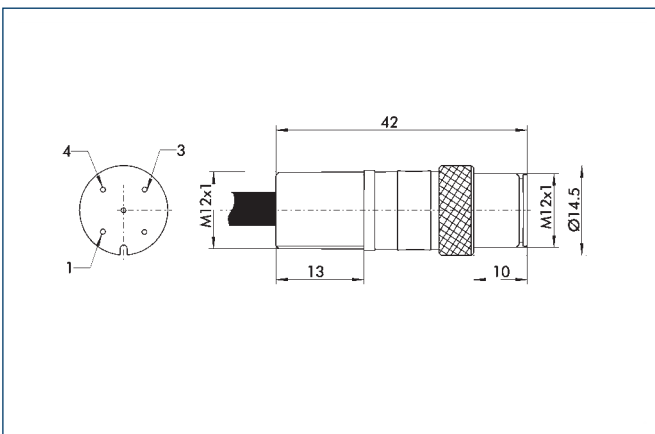



Circuit diagram of closer

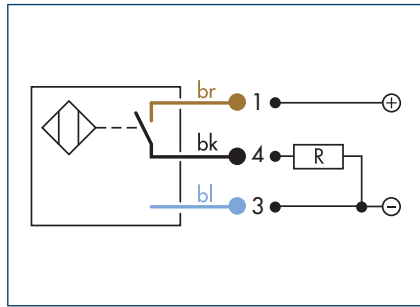

Circuit diagram of opener

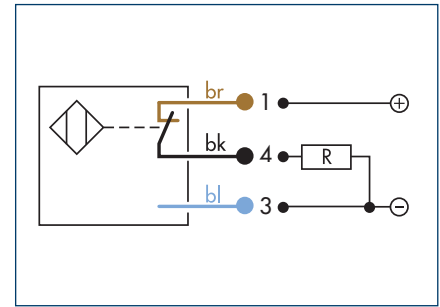

Technical data

Description		IN 40/S-M8	IN 40/S-M12	INK 40/S	IN 40/O-M8	IN 40/O-M12	INK 40/O
	ID	0301474	0301574	0301555	0301484	0301584	0301556
Switching function		Closer	Closer	Closer	Opener	Opener	Opener
Switching distance	[mm]	0.8	0.8	0.8	0.8	0.8	0.8
Hysteresis of nominal switching distance		< 15%	< 15%	< 15%	< 15%	< 15%	< 15%
Switching method		PNP	PNP	PNP	PNP	PNP	PNP
Cable length	[cm]	30.0	30.0	200.0	30.0	30.0	200.0
Cable connector/cable end		M8	M12	Open wire	M8	M12	Open wire
Type of voltage		DC	DC	DC	DC	DC	DC
Nominal voltage	[V]	24.0	24.0	24.0	24.0	24.0	24.0
Min. voltage	[V]	10.0	10.0	10.0	10.0	10.0	10.0
Max. voltage	[V]	30.0	30.0	30.0	30.0	30.0	30.0
Voltage drop	[V]	1.5	1.5	1.5	1.5	1.5	1.5
Max. power on contact	[A]	0.2	0.2	0.2	0.2	0.2	0.2
Min. ambient temperature	[°C]	-25.0	-25.0	-25.0	-25.0	-25.0	-25.0
Max. ambient temperature	[°C]	70.0	70.0	70.0	70.0	70.0	70.0
Max. switching frequency	[Hz]	1000.0	1000.0	1000.0	1000.0	1000.0	1000.0
IP rating (sensor)		67	67	67	67	67	67
IP rating (connector, plugged in)		67	67	67	67	67	67
LED display on sensor		Yes	Yes	Yes	Yes	Yes	Yes
Cable diameter	[mm]	3.5	3.5	3.5	3.5	3.5	3.5
Min. bending radius (dynamic)	[mm]	35.0	35.0	35.0	35.0	35.0	35.0
Min. bending radius (static)	[mm]	17.5	17.5	17.5	17.5	17.5	17.5
No. of wires		3	3	3	3	3	3
Wire cross section	[mm ²]	0.14	0.14	0.14	0.14	0.14	0.14

IN 40 sensor

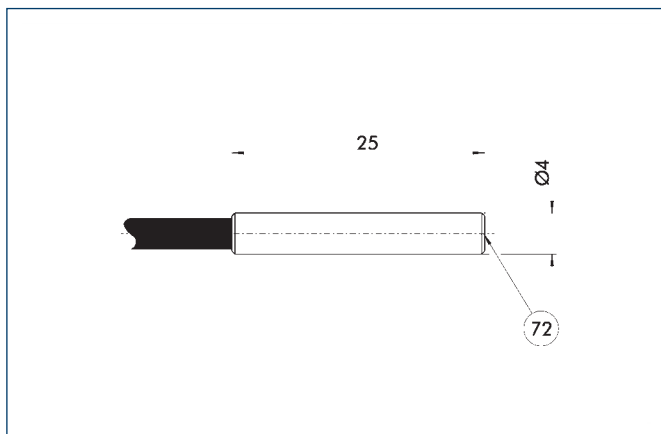

72 Active sensor surface

M8 connector

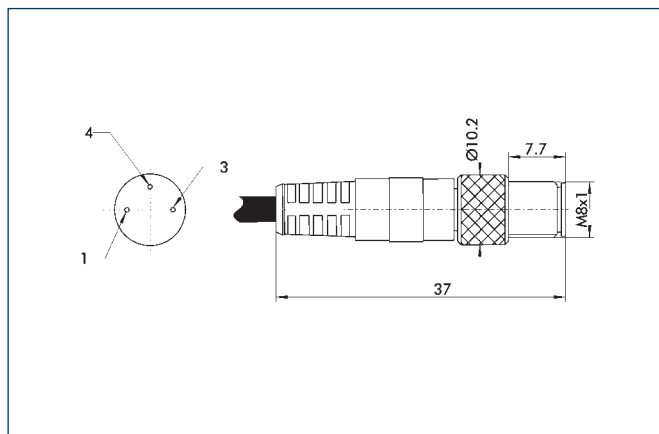

M12 connector

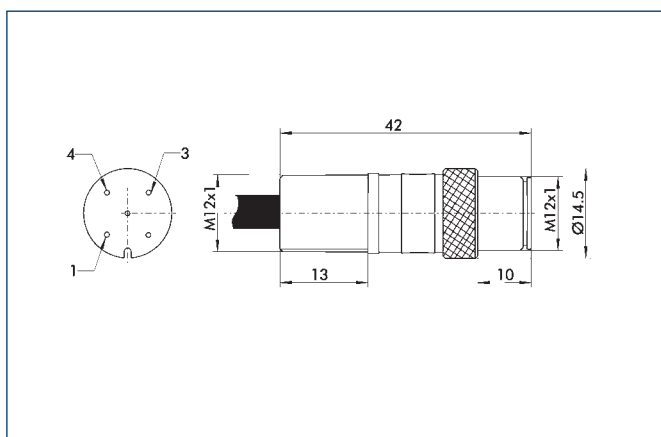

Circuit diagram of closer

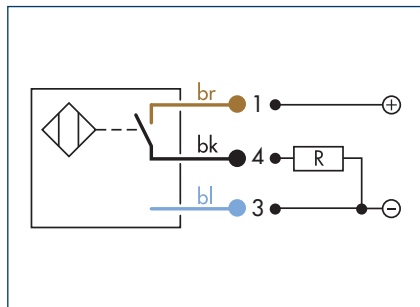

Technical data

Description	ID	IN 60/S-M8	IN 60/S-M12	INK 60/S
		0301485	0301585	0301553
Switching function		Closer	Closer	Closer
Switching distance	[mm]	1.5	1.5	1.5
Hysteresis of nominal switching distance		< 15%	< 15%	< 15%
Switching method		PNP	PNP	PNP
Cable length	[cm]	30.0	30.0	200.0
Cable connector/cable end		M8	M12	Open wire
Type of voltage		DC	DC	DC
Nominal voltage	[V]	24.0	24.0	24.0
Min. voltage	[V]	10.0	10.0	10.0
Max. voltage	[V]	30.0	30.0	30.0
Voltage drop	[V]	1.5	1.5	1.5
Max. power on contact	[A]	0.2	0.2	0.2
Min. ambient temperature	[°C]	-25.0	-25.0	-25.0
Max. ambient temperature	[°C]	70.0	70.0	70.0
Max. switching frequency	[Hz]	1000.0	1000.0	1000.0
IP rating (sensor)		67	67	67
IP rating (connector, plugged in)		67	67	67
LED display on sensor		No	No	No
Cable diameter	[mm]	3.5	3.5	3.5
Min. bending radius (dynamic)	[mm]	35.0	35.0	35.0
Min. bending radius (static)	[mm]	17.5	17.5	17.5
No. of wires		3	3	3
Wire cross section	[mm ²]	0.14	0.14	0.14

IN 60/S sensor

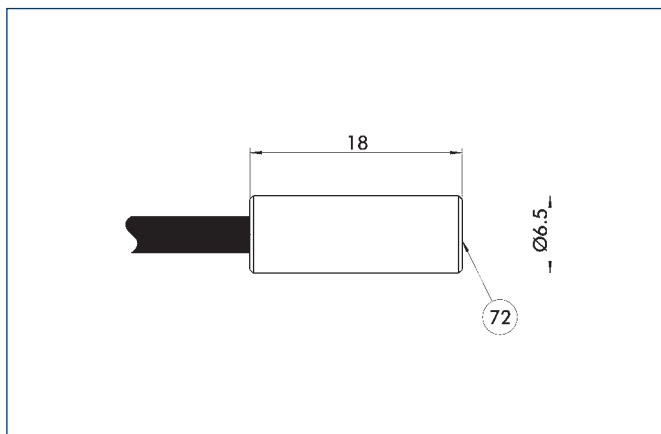

72 Active sensor surface

M8 connector

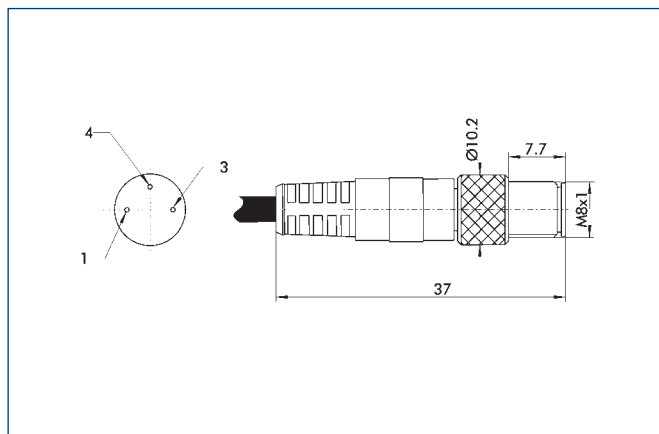

M12 connector

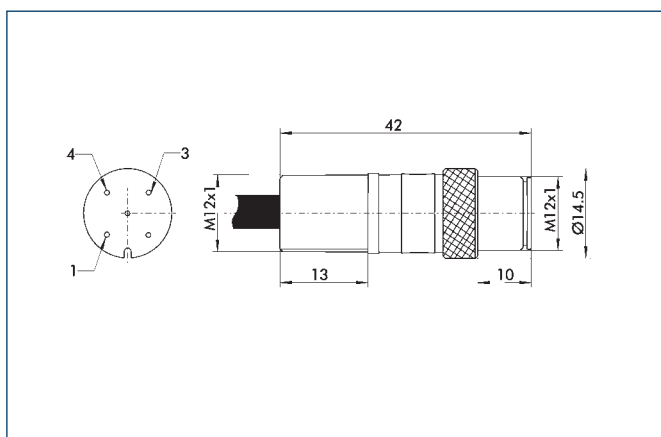

Circuit diagram of closer

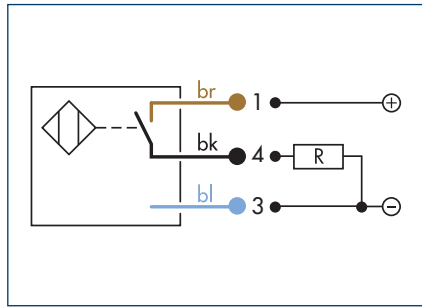

Technical data

Description	ID	IN 65/S-M8	IN 65/S-M12	IN K 65/S
		0301476	0301576	0301554
Switching function		Closer	Closer	Closer
Switching distance	[mm]	1.5	1.5	1.5
Hysteresis of nominal switching distance		< 15%	< 15%	< 15%
Switching method		PNP	PNP	PNP
Cable length	[cm]	30.0	30.0	200.0
Cable connector/cable end		M8	M12	Open wire
Type of voltage		DC	DC	DC
Nominal voltage	[V]	24.0	24.0	24.0
Min. voltage	[V]	10.0	10.0	10.0
Max. voltage	[V]	30.0	30.0	30.0
Voltage drop	[V]	1.5	1.5	1.5
Max. power on contact	[A]	0.2	0.2	0.2
Min. ambient temperature	[°C]	-25.0	-25.0	-25.0
Max. ambient temperature	[°C]	70.0	70.0	70.0
Max. switching frequency	[Hz]	1000.0	1000.0	1000.0
IP rating (sensor)		67	67	67
IP rating (connector, plugged in)		67	67	67
LED display on sensor		Yes	Yes	No
Cable diameter	[mm]	3.5	3.5	3.5
Min. bending radius (dynamic)	[mm]	35.0	35.0	35.0
Min. bending radius (static)	[mm]	17.5	17.5	17.5
No. of wires		3	3	3
Wire cross section	[mm ²]	0.14	0.14	0.14

IN 65/S sensor

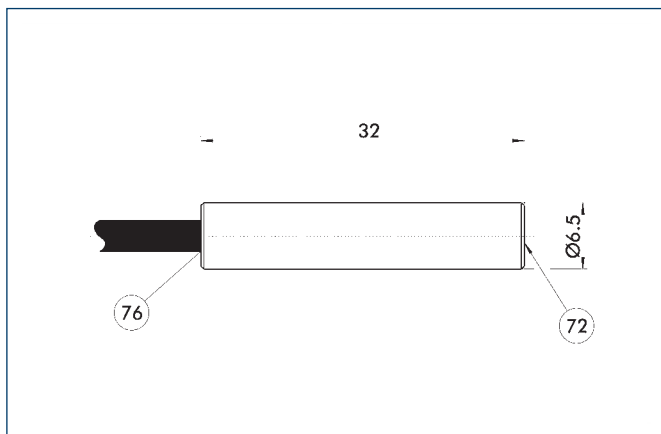

- 72 Active sensor surface
- 76 LED

M8 connector

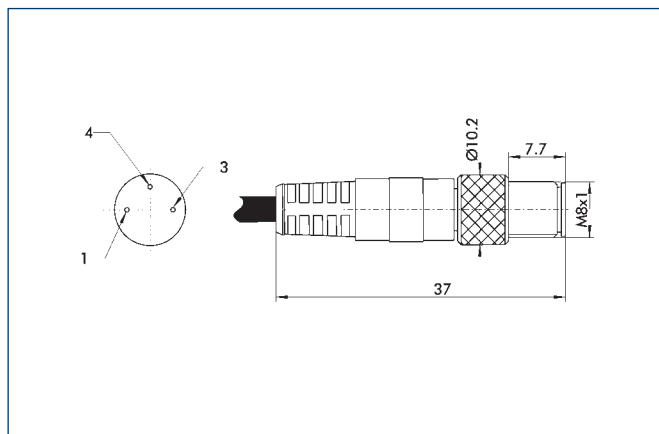

M12 connector

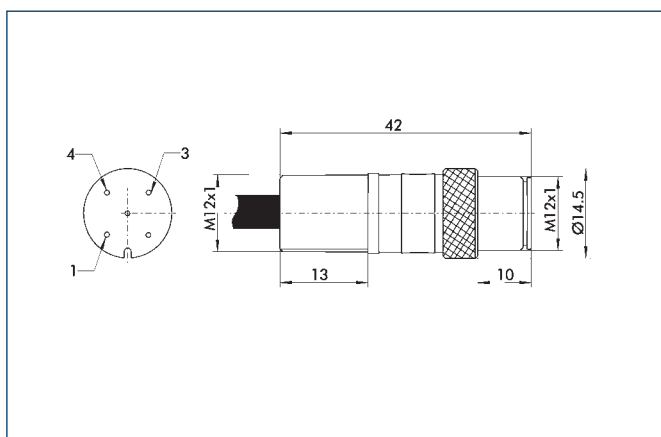



Circuit diagram of closer

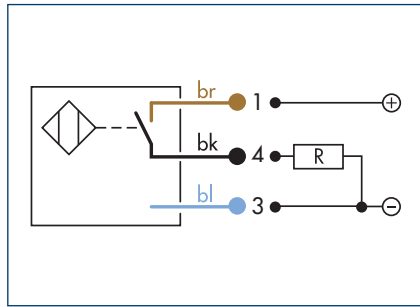

Circuit diagram of opener

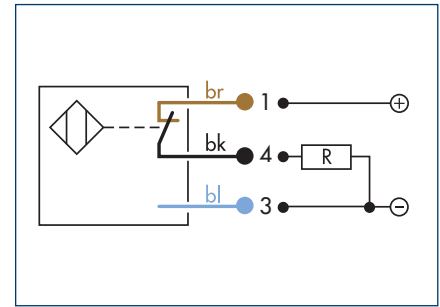

Technical data

Description		IN 80/S-M8	IN 80/S-M12	INK 80/S	IN 80/O-M8	IN 80/O-M12	INK 80/O
	ID	0301478	0301578	0301550	0301488	0301588	0301551
Switching function		Closer	Closer	Closer	Opener	Opener	Opener
Switching distance	[mm]	1.5	1.5	1.5	1.5	1.5	1.5
Hysteresis of nominal switching distance		< 15%	< 15%	< 15%	< 15%	< 15%	< 15%
Switching method		PNP	PNP	PNP	PNP	PNP	PNP
Cable length	[cm]	30.0	30.0	200.0	30.0	30.0	200.0
Cable connector/cable end		M8	M12	Open wire	M8	M12	Open wire
Type of voltage		DC	DC	DC	DC	DC	DC
Nominal voltage	[V]	24.0	24.0	24.0	24.0	24.0	24.0
Min. voltage	[V]	10.0	10.0	10.0	10.0	10.0	10.0
Max. voltage	[V]	30.0	30.0	30.0	30.0	30.0	30.0
Voltage drop	[V]	1.5	1.5	1.5	1.5	1.5	1.5
Max. power on contact	[A]	0.2	0.2	0.2	0.2	0.2	0.2
Min. ambient temperature	[°C]	-25.0	-25.0	-25.0	-25.0	-25.0	-25.0
Max. ambient temperature	[°C]	70.0	70.0	70.0	70.0	70.0	70.0
Max. switching frequency	[Hz]	1000.0	1000.0	1000.0	1000.0	1000.0	1000.0
IP rating (sensor)		67	67	67	67	67	67
IP rating (connector, plugged in)		67	67	67	67	67	67
LED display on sensor		Yes	Yes	Yes	Yes	Yes	Yes
Cable diameter	[mm]	3.5	3.5	3.5	3.5	3.5	3.5
Min. bending radius (dynamic)	[mm]	35.0	35.0	35.0	35.0	35.0	35.0
Min. bending radius (static)	[mm]	17.5	17.5	17.5	17.5	17.5	17.5
No. of wires		3	3	3	3	3	3
Wire cross section	[mm ²]	0.14	0.14	0.14	0.14	0.14	0.14

IN 80 sensor

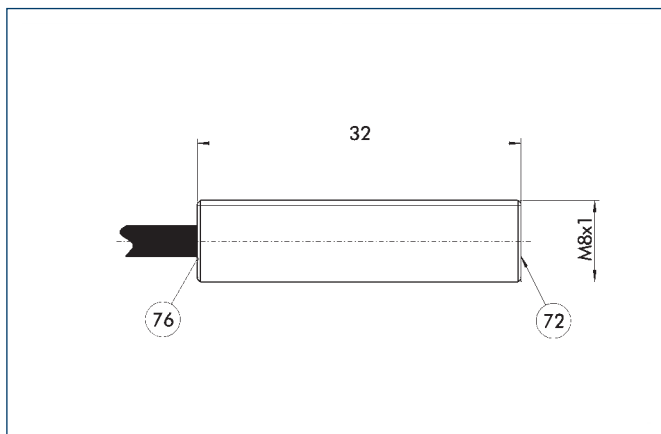

72 Active sensor surface

76 LED

M8 connector

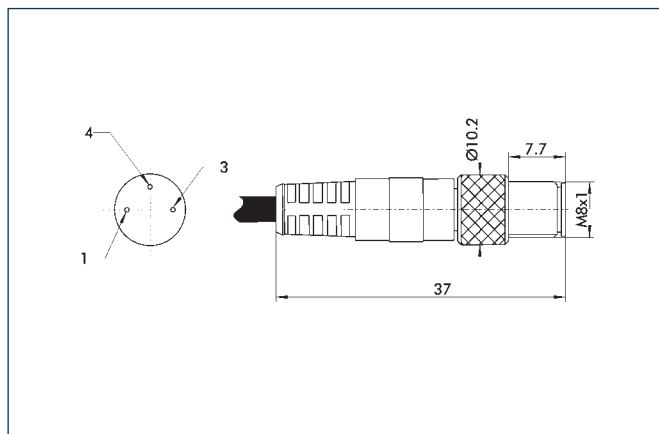

M12 connector

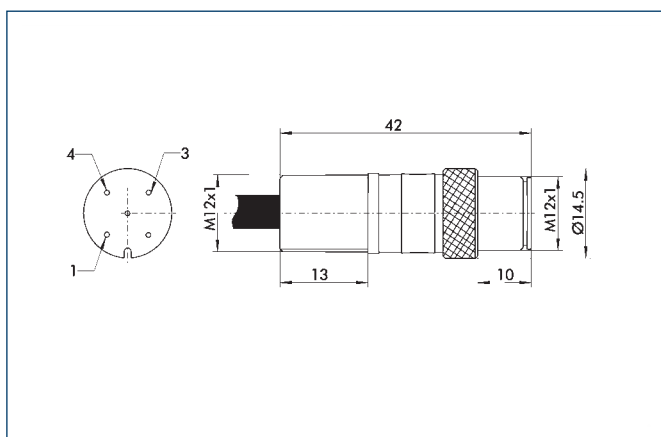

Circuit diagram of closer

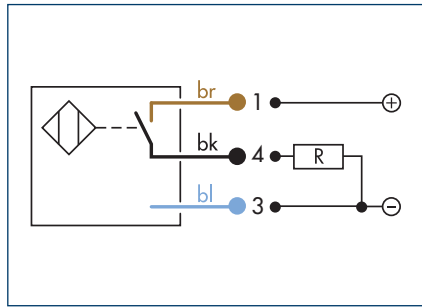

Technical data

Description	ID	IN-B 80/S-M8	IN 80/SL-M12	INK 80/SL
		0301477	0301529	0301579
Switching function		Closer	Closer	Closer
Switching distance	[mm]	1.5	3.0	3.0
Hysteresis of nominal switching distance		< 15%	< 15%	< 15%
Switching method		PNP	PNP	PNP
Cable length	[cm]		30.0	200.0
Cable connector/cable end		M8	M12	Open wire
Type of voltage		DC	DC	DC
Nominal voltage	[V]	24.0	24.0	24.0
Min. voltage	[V]	10.0	10.0	10.0
Max. voltage	[V]	30.0	30.0	30.0
Voltage drop	[V]	1.5	1.5	1.5
Max. power on contact	[A]	0.2	0.2	0.2
Min. ambient temperature	[°C]	-25.0	-25.0	-25.0
Max. ambient temperature	[°C]	70.0	70.0	70.0
Max. switching frequency	[Hz]	1000.0	1000.0	1000.0
IP rating (sensor)		67	67	67
IP rating (connector, plugged in)		67	67	67
LED display on sensor		Yes	Yes	Yes
Cable diameter	[mm]		3.5	3.5
Min. bending radius (dynamic)	[mm]		35.0	35.0
Min. bending radius (static)	[mm]		17.5	17.5
No. of wires/contacts		3	3	3
Wire cross section	[mm ²]		0.14	0.14

IN B-80 sensor

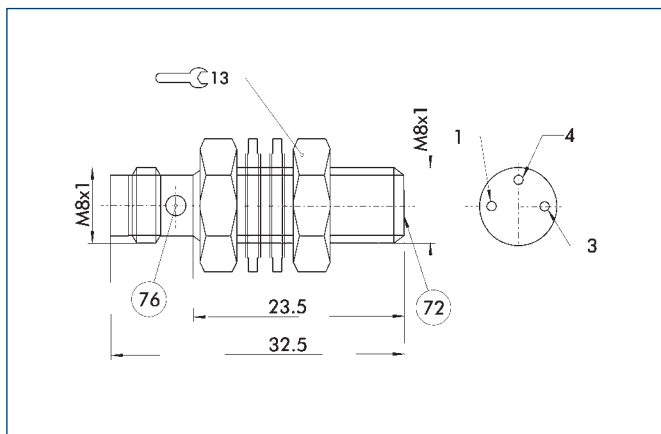

72 Active sensor surface

76 LED

IN 80/SL sensor

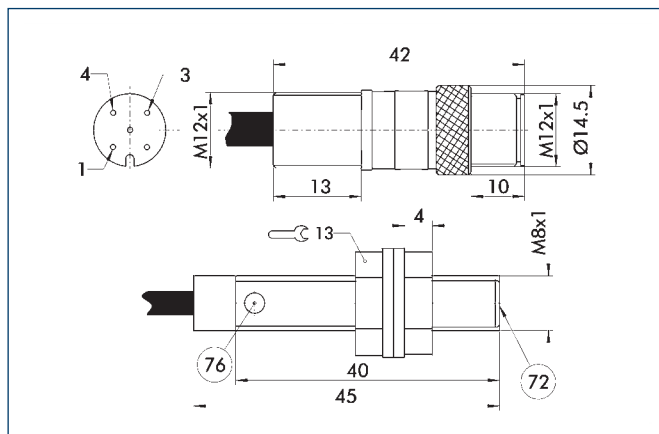

72 Active sensor surface

76 LED

Circuit diagram of closer

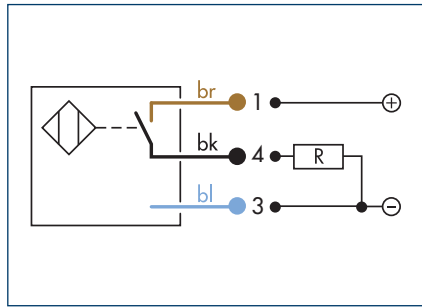

Technical data

Description	ID	IN 120/S-M12 0301592	INK 120/S 0301562
Switching function		Closer	Closer
Switching distance	[mm]	2.0	2.0
Hysteresis of nominal switching distance		< 15%	< 15%
Switching method		PNP	PNP
Cable length	[cm]	30.0	200.0
Cable connector/cable end		M12	Open wire
Type of voltage		DC	DC
Nominal voltage	[V]	24.0	24.0
Min. voltage	[V]	10.0	10.0
Max. voltage	[V]	30.0	30.0
Voltage drop	[V]	1.5	1.5
Max. power on contact	[A]	0.2	0.2
Min. ambient temperature	[°C]	-25.0	-25.0
Max. ambient temperature	[°C]	70.0	70.0
Max. switching frequency	[Hz]	1000.0	1000.0
IP rating (sensor)		67	67
IP rating (connector, plugged in)		67	67
LED display on sensor		No	No
Cable diameter	[mm]	3.5	3.5
Min. bending radius (dynamic)	[mm]	35.0	35.0
Min. bending radius (static)	[mm]	17.5	17.5
No. of wires		3	3
Wire cross section	[mm ²]	0.14	0.14

IN 120/S sensor

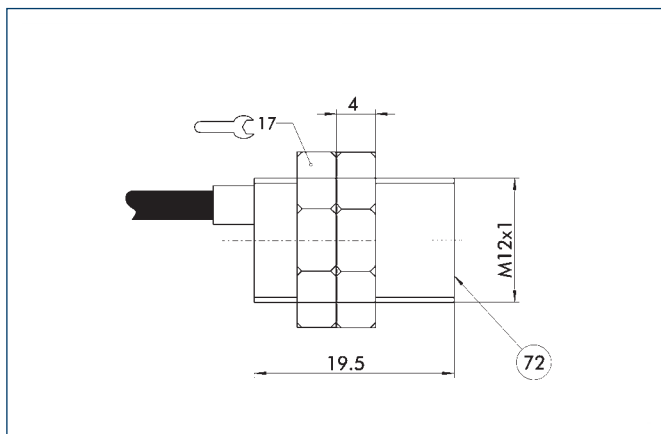

72 Active sensor surface

M12 connector

