

Gripping force
100 N
22.5 lbf

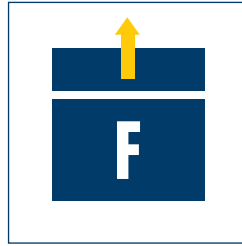

Torque
0.9 Nm
0.664 lbf ft



Piston force (extended)
250 N
56 lbf

Application example



KONEX weight-reduced, modular gripping system for economical automation in assembly and production

- 1** KONEX P 50
2-Finger Parallel Gripper
- 2** KONEX V 55 Connector
- 3** KONEX S 50 Rotary Unit

- 4** KONEX V 50 Connector
- 5** KONEX H 50 Linear Unit

Modular Gripping System

Weight-reduced, low-price gripping system consisting of a linear unit, a gripper and a rotary unit connected with snap-on connectors, so that the modules do not need to be screwed in place

Area of application

Suitable for clean environments and light loads

Your advantages and benefits

Low-price gripping system

comprising rotary unit, linear unit and parallel gripper

Complete series weight-reduced through the use of a high-performance polymer

making the modules extremely light and free from corrosion

Simple connection of the various components using snap-on connectors

enabling easy, fast assembly of modules



Information about the series

Working principle

Pneumatic piston drive, with transmission to a pinion in the case of the rotary unit

Housing material

High-performance polymer

Actuation

Pneumatic, with filtered compressed air (10 µm): Dry, lubricated or non-lubricated
Pressure medium: Required quality class of compressed air according to DIN ISO 8573-1: Quality class 4

Warranty

24 months

Scope of delivery

Brackets for proximity switches (gripper only), assembly and operating manual with manufacturer's declaration

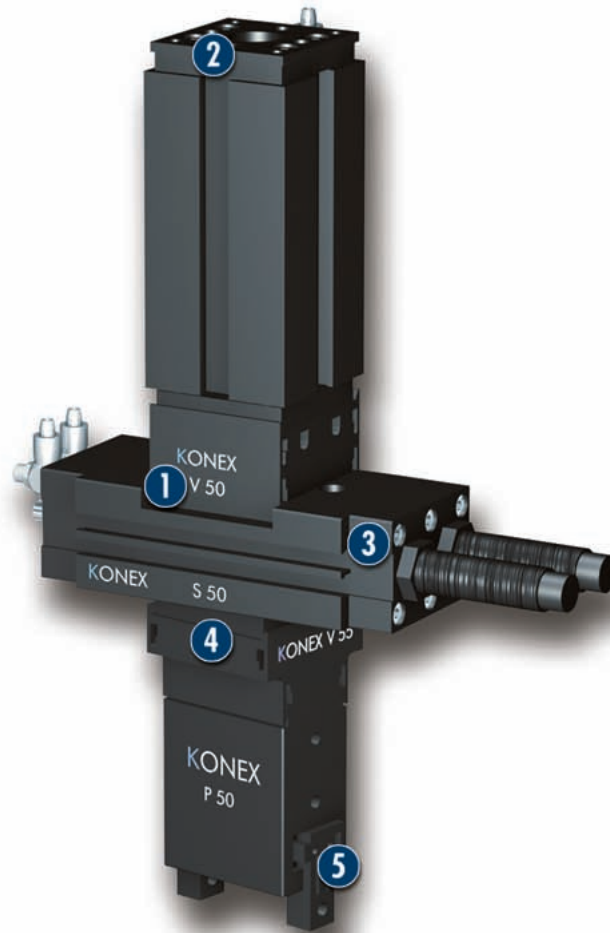

- 1 V 50 Connector**
for connecting linear units and rotary units in any direction, attachable at 90° intervals
- 2 KONEX H**
weight-reduced Linear Unit

- 3 KONEX S**
weight-reduced Rotary Unit
- 4 V 55 Connector**
for connecting a Rotary Unit, or a Linear Unit, to a gripper, attachable at 90° intervals

- 5 KONEX P**
weight-reduced Parallel Gripper

Function description

The KONEX series works with pneumatics. The gripper functions by means of a pneumatic piston, the rotary unit on the basis of a double-piston rack and pinion principle and the linear unit through the direct connection of the lifting plate to the piston rod.

Options and special information

Thanks to the snap-on connectors, the individual modules are mounted within seconds.

Accessories

SCHUNK accessories — the suitable complement for the highest level of functionality, reliability and controlled production of all automation modules.

Centering sleeves



Fittings



MMS magnetic switch



IN inductive proximity switches



Quentes plastic inserts



W/WK/KV/GK sensor cables



HKI gripper pads

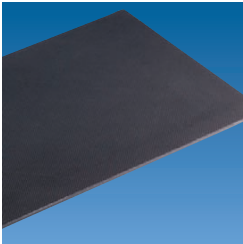

V sensor distributors



SDV-P pressure maintenance valves



Connector



① For the exact size of the required accessories, availability of this size and the designation and ID, please refer to the additional views at the end of the size in question. You can find more detailed information on our accessory range in the "Accessories" catalog section.

General information on the series

Gripping force

is the arithmetic total of the gripping force applied to each base jaw at distance P (see illustration), measured from the upper edge of the gripper.

Finger length

is measured from the upper edge of the gripper housing in the direction of the main axis.

Repeat accuracy

is defined as the spread of the limit position after 100 consecutive strokes.

V 50 and V 55 connectors

The linear unit is connected to the rotary unit via the V 50 connector. The gripper can be secured to the linear unit or rotary unit via the V 55 connector.

Closing and opening times

Closing and opening times are purely the times that the base jaws or fingers are in motion. Valve switching times, hose filling times or PLC reaction times are not included in the above times and must be taken into consideration when determining cycle times.



Moment load

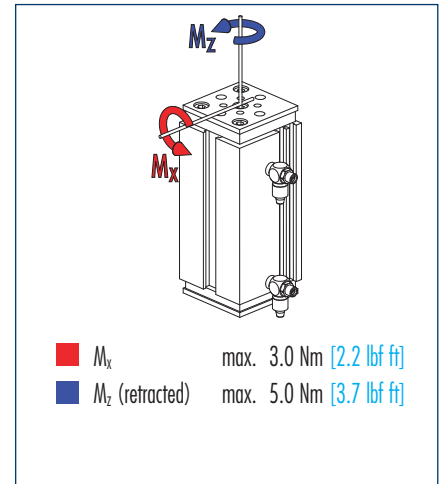

① The loading forces and moments may occur simultaneously.

Technical data

Description	ID	Konex H 50
Extension force	N [lbf]	250.0 [56]
Retraction force	N [lbf]	180.0 [40]
Stroke	mm [in]	60.0 [2.362]
Weight	kg [lbs]	0.45 [0.99]
Max. permitted torsional moment (extended)	Nm [lbf ft]	2.0 [1.5]
Air consumption per double stroke	cm ³ [in ³]	54.0 [3.30]
Nominal operating pressure	bar [psi]	6.0 [87]
Max. permitted operating pressure	bar [psi]	6.5 [94]
Stroke time (extended)	s	0.07
IP class		42
Min. ambient temperature	°C [°F]	5.0 [41]
Max. ambient temperature	°C [°F]	60.0 [140]
Repeat accuracy	mm [in]	0.2 [0.0079]

Main views

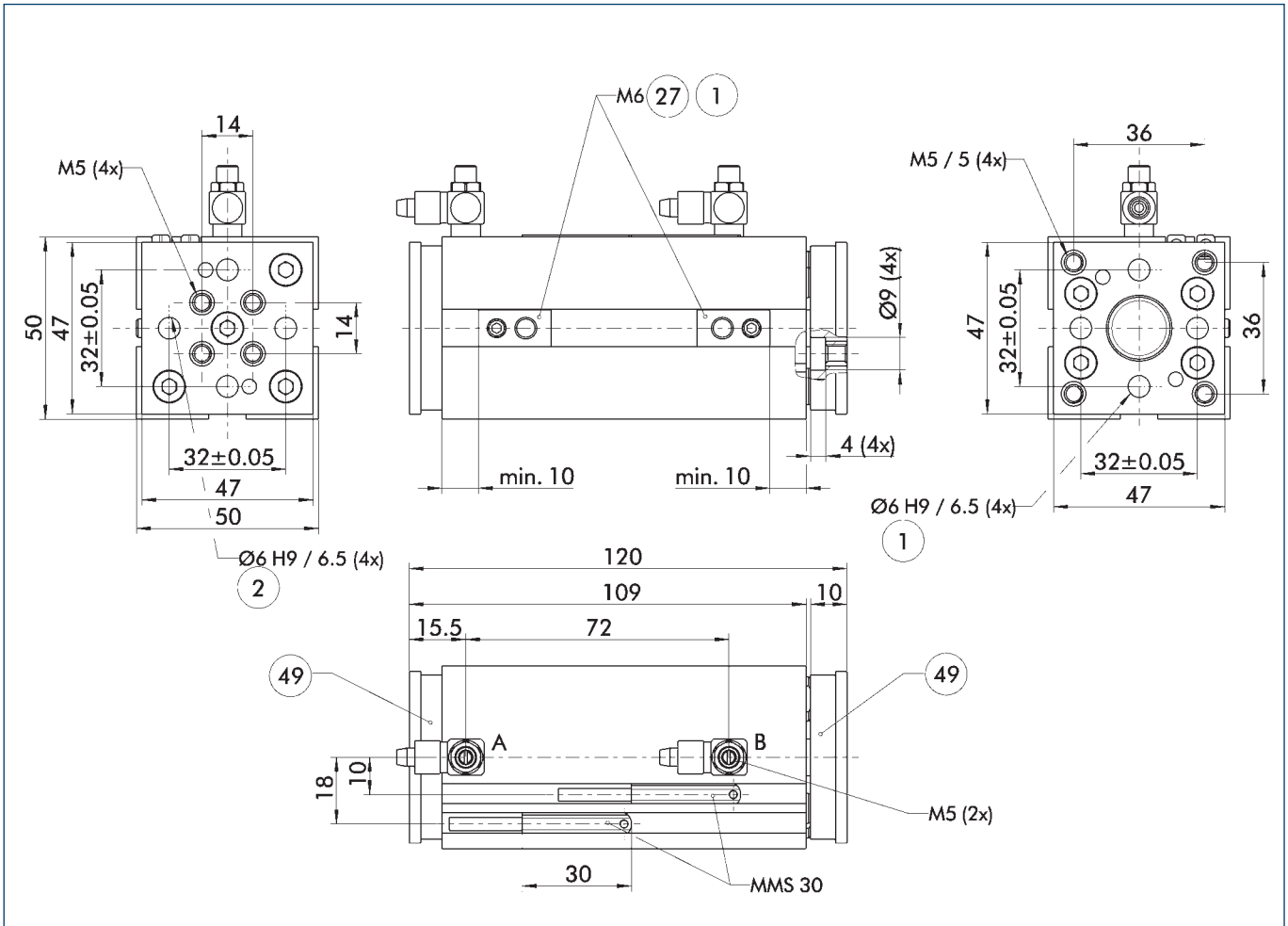

The drawing shows the unit in the basic version, the dimensions do not include the option described below.

① The SDV-P pressure maintenance valve can be used to hold the position upon a loss of pressure (see "Accessories" catalog section).

- A,a Main/direct connection, extend linear unit
- B,b Main/direct connection, retract linear unit
- ① Linear unit connection
- ② Connection of the unit
- 27 Fastening groove for T-nuts
- 49 Undercut for snap-on connection

KONEX V 50 connecting element

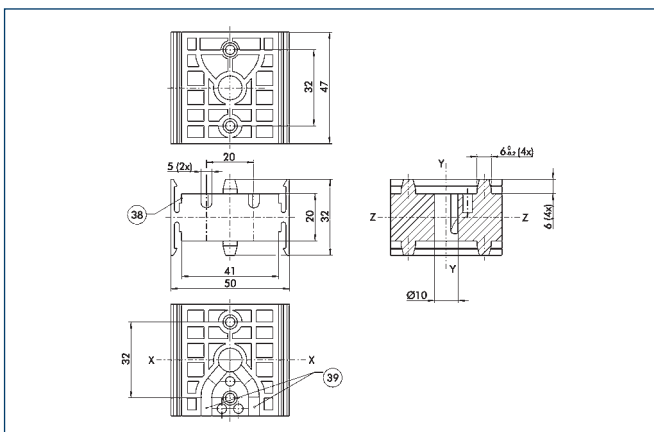

- 38 Slot for disassembly tool
- 39 Slot for air hose Ø4

Connecting element between linear unit and rotary unit

Adapter plate

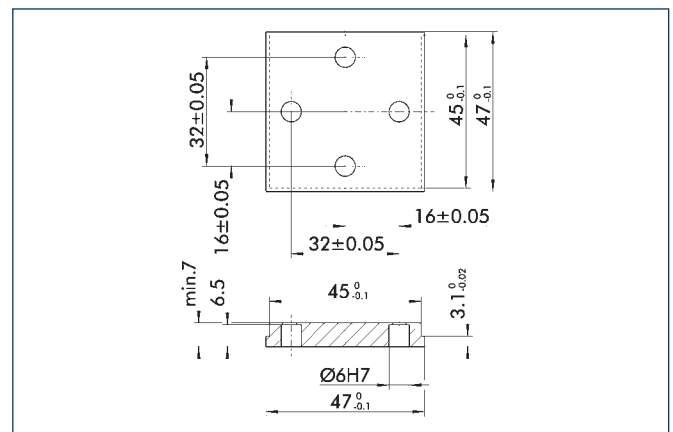

For connecting any modules you require to the linear unit or rotary unit with the V 50 connecting element.

KONEX V 55 connecting element

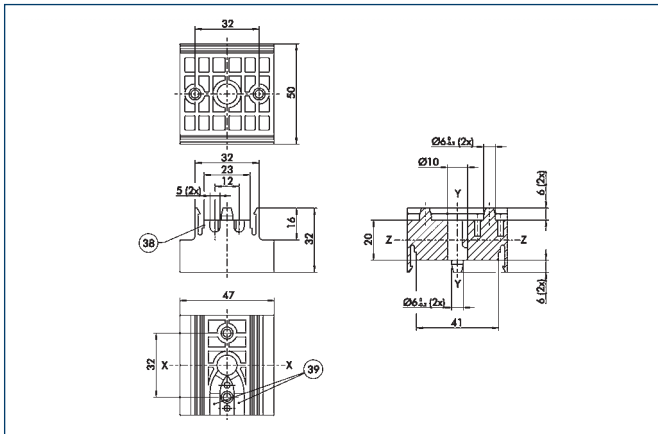

- 38 Slot for disassembly tool
- 39 Slot for air hose Ø4

Connecting element between gripper and linear unit or rotary unit

Adapter plate

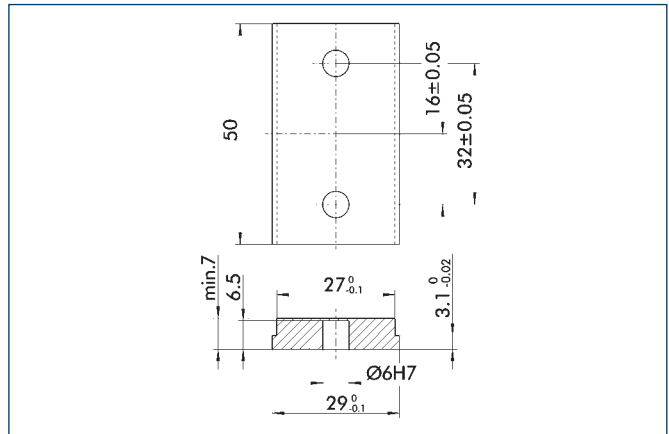

For connecting any modules you require to the linear unit or rotary unit with the V 55 connecting element.

Bending moment

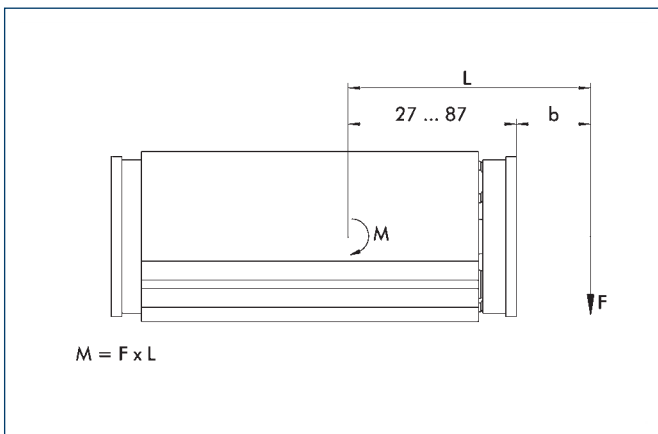

The drawing shows the center of rotation on which the leverage is based for the purpose of the bending moment calculation.



You can find more detailed information and individual parts of the above-mentioned accessories in the "Accessories" catalog section.

Sensor system

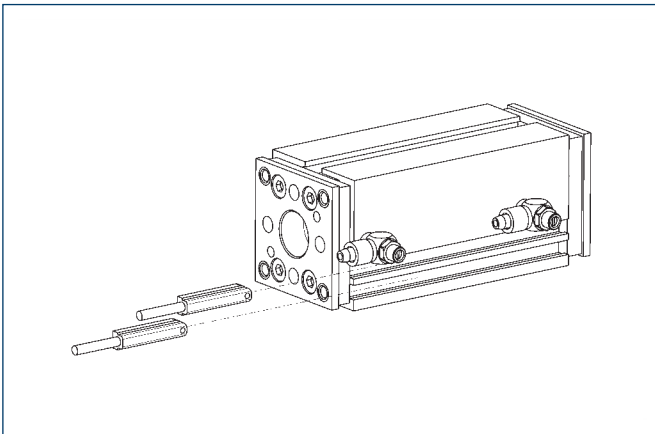

End position monitoring:

Electronic magnetic switches, for direct mounting

Description	ID	Recommended product
MMS 30-S-M12-PNP	0301571	
MMS 30-S-M8-PNP	0301471	•
MMSK 30-S-PNP	0301563	

① Two sensors (NO contacts) are required for each unit.

Extension cables for proximity switches/magnetic switches

Description	ID
GK 3-M8	0301622
KV 10-M12	0301596
KV 10-M8	0301496
KV 20-M12	0301597
KV 20-M8	0301497
KV 3-M12	0301595
KV 3-M8	0301495
WK 3-M8	0301594
WK 5-M8	0301502

① Please note the minimum permitted bending radii for the sensor cables, which are generally 35 mm.

 You can find more detailed information and individual parts of the above-mentioned accessories in the “Accessories” catalog section.