

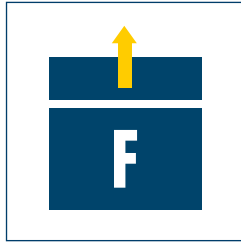

Useful stroke
up to 2,800 mm

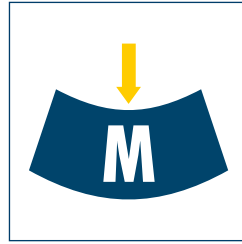

Driving force
up to 1,500 N



Deflection
0.1 mm .. 1 mm

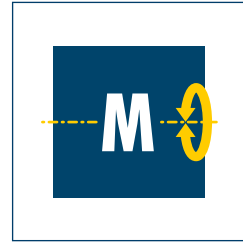

Moment load
Max. 810 Nm

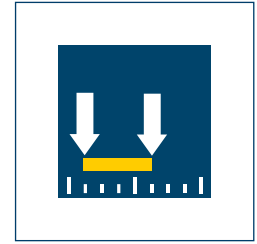

Repeat accuracy
0.01 mm

Module design

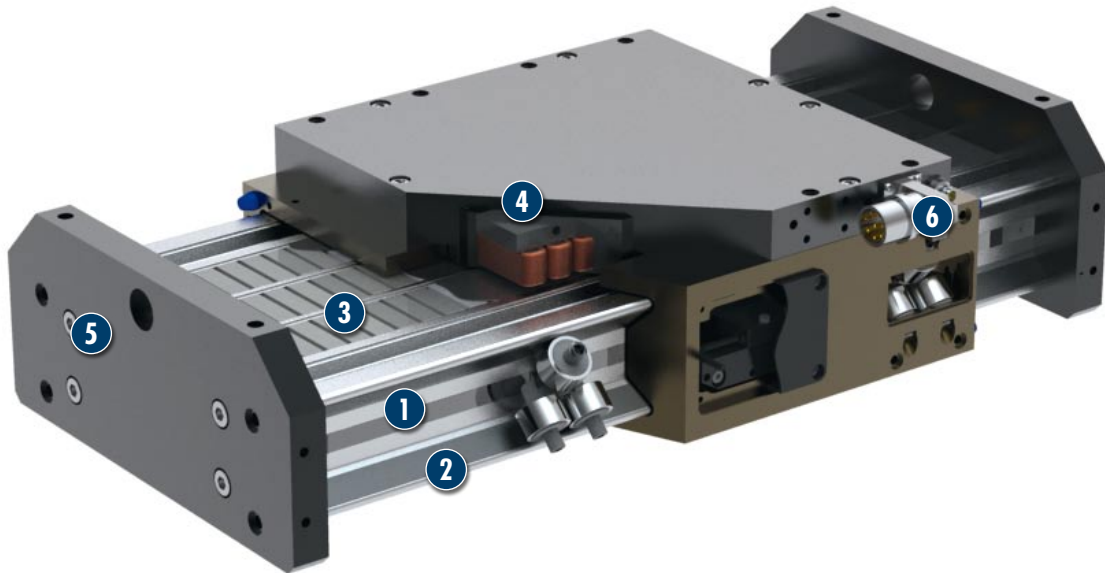

- 1 Elongated X-shaped aluminum press-drawn section**
with high planar moments of inertia for maximum moment and shearing force load
- 2 High precision, hardened and ground steel guide rails**
for optimum guidance properties and speeds
- 3 Integrated secondary parts**
with high power magnets
- 4 Compact primary part slide**
with mounting surfaces, rollers adjusted without play and integrated measuring system
- 5 End plates**
for mounting sensors and shock absorbers
- 6 Motor plug**

Linear axis with direct drive

and roller guide

Area of application

Self-supporting heavy load profile for applications with high payloads

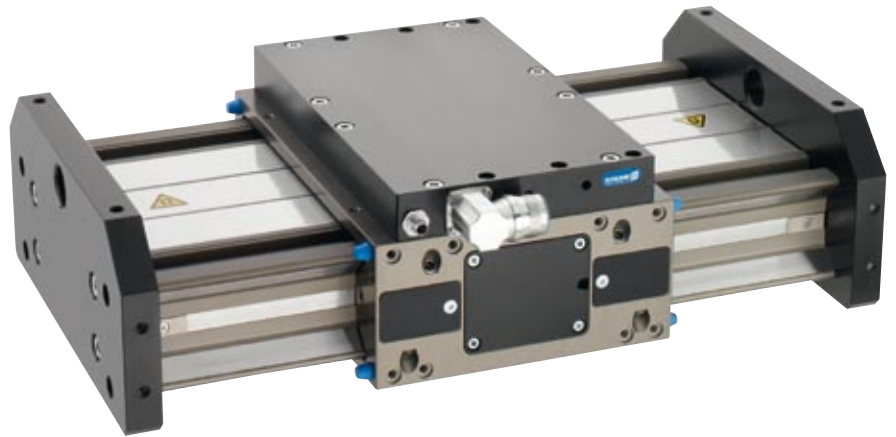

General information about the series

Drive

3-phase, electronically commutated AC synchronous linear motor. Primary part 3-phase copper coil body, secondary part iron mount with permanent magnets and dirt cover.

Stroke measuring system

Non-contact magnetic measuring system with integrated analog signal output, 1 Vss (insensitive to contamination)

Profile guide

X-shaped aluminum press-drawn section with ground tracks with a secondary part made up of high power magnets

Guided slide

Roller-guided slide adjustable with no play using cam, primary part and measuring system reading head directly integrated. Attachments can be mounted and secured using thread and centering sleeves on all four side surfaces.

Operating temperature

From 10 °C to 40 °C

Options

- **Pneumatic brake for relieving the load on the linear motor, e.g. under influence of axial forces in target position**
- Other independent motor slides on a common profile guide and with a linear measuring system
- Collision protection in case of programming errors is provided by corresponding limit switches
- Second passive guided slide for long attachments (free moving)
- Wipers for removing deposits on the guideways.
- Absolute stroke measuring system and optical stroke measuring systems for applications with very high accuracy

Accessories

- Control units from Bosch Rexroth or Siemens (other manufacturers on request)
- Limit switching using either mechanical or inductive sensors; referencing using inductive sensors
- Hydraulic shock absorbers on profile end plates to prevent inelastic collisions (size and number of shock absorbers depend on application)
- Cable track, pre-assembled and mounted on drive
- Adapter plates on request
- Pre-assembled cable sets in different lengths

Warranty

24 months

① Refer to ambient conditions on our introductory pages

For production reasons, the colors may vary from those shown in the catalog.



Load data

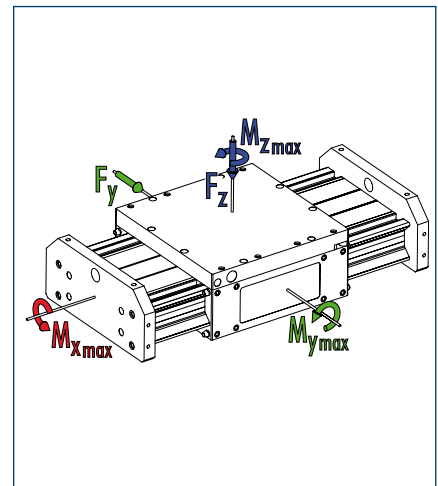

	MLD T	MLD TL
M_x max. [Nm]	600	600
M_y max. [Nm]	410	700
M_z max. [Nm]	680	810

Technical data

Designation		MLD 200T	MLD 300T	MLD 200TL	MLD 400TL	MLD 600TL
Max. driving force (*)	[N]	500	750	500	1000	1500
Rated force (**)	[N]	170	225	208	288	393
Max. speed	[m/s]	4	4	4	4	4
Max. acceleration	[m/s ²]	40	40	40	40	40
Max. useful load (horizontal)	[kg]	25	25	50	50	50
Max. stroke	[mm]	2800	2800	2700	2700	2700
Repeat accuracy (***)	[mm]	0.01	0.01	0.01	0.01	0.01
Measuring system resolution (controller-dependent)	[µm]	0.5	0.5	0.5	0.5	0.5
Max. current	(A_{eff})	16.2	24.3	16.2	32.4	48.6
Max. continuous current at standstill	(A_{eff})	4.2	5.6	5.2	7.2	9.8
Max. ambient temperature	[°C]	40	40	40	40	40
Max. surface temperature	[°C]	70	70	70	70	70
Weight of guided slide inc. motor	[kg]	6.6	7.0	9.4	11.1	12.0
Weight of end plates	[kg]	2.8	2.8	2.8	2.8	2.8
Profile / 100mm stroke	[kg]	1.75	1.96	1.53	1.75	1.96

(*) Depending on controller type used

(**) Depending on installation situation (heat dissipation)

(***) The specified repeat accuracies are only applicable at constant ambient temperatures.

① The specified repeat accuracy applies at constant ambient temperatures.

Some of the specified forces can vary considerably when using different control units and with increasing travel speeds

Main views MLD T

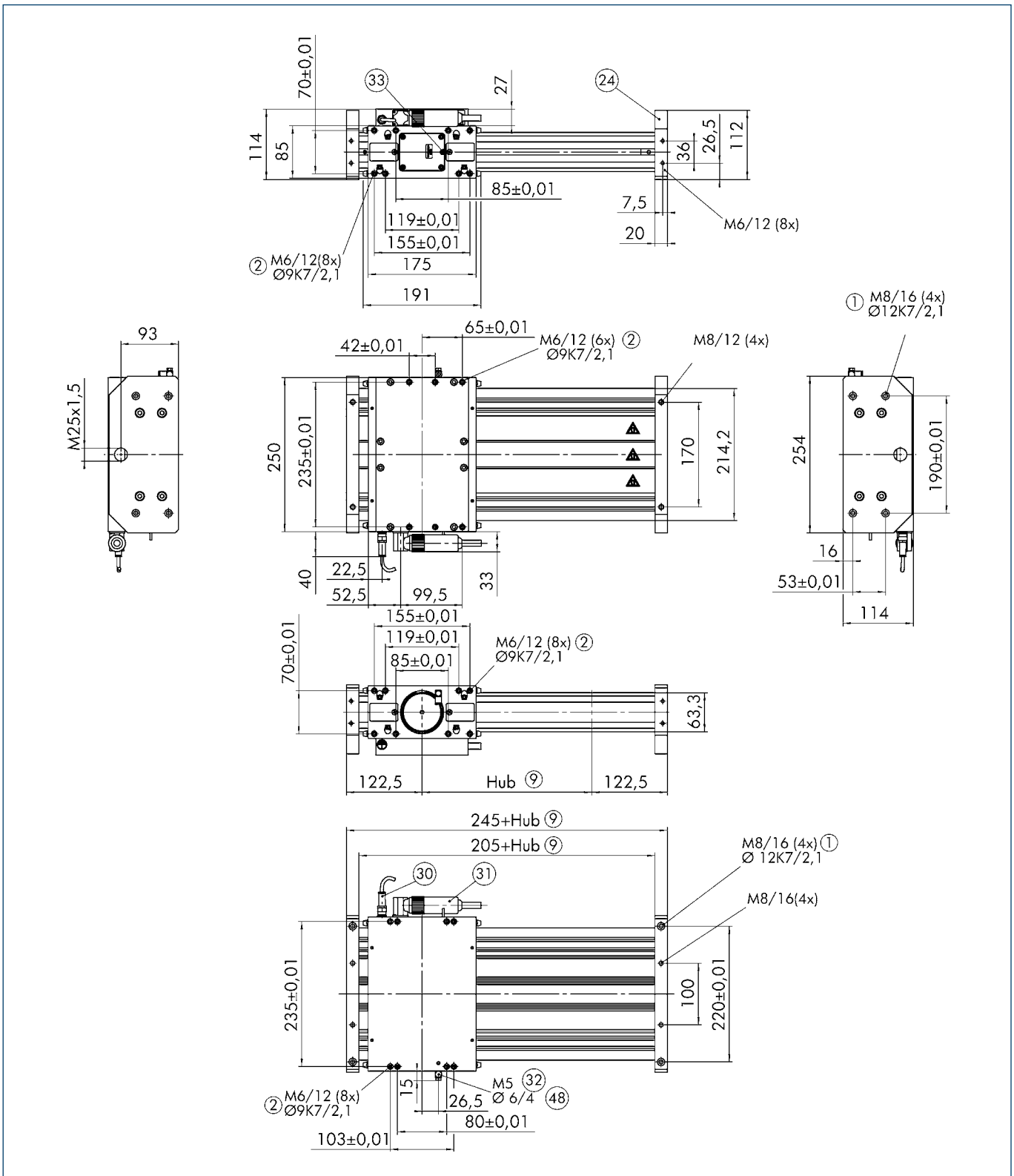

- | | |
|--------------------------------|--|
| ① Linear unit connection | ③② Pneumatic connection for holding brake |
| ② Assembly connection | ③③ Cable for stroke measuring system |
| ⑨ Useful stroke | ④⑧ Hose diameter |
| ②④ Flange | ⑦③ Depth of centering sleeve hold in adapter plate |
| ③① Hall sensor connecting plug | |
| ③① Motor plug | |

Main views MLD TL

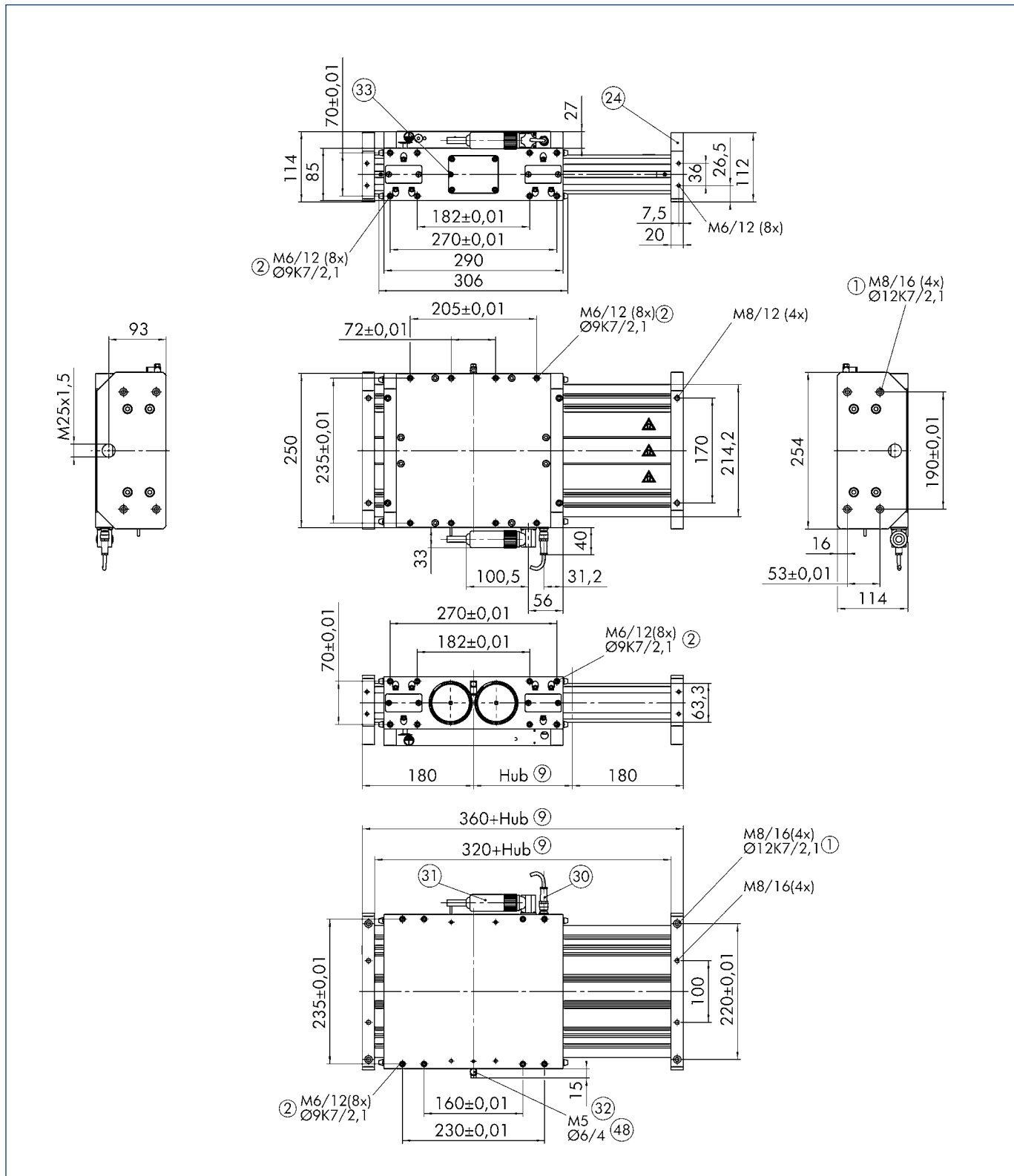

- | | |
|--------------------------|--|
| ① Linear unit connection | ③② Pneumatic connection for holding brake |
| ② Assembly connection | ③③ Cable for stroke measuring system |
| ⑨ Useful stroke | ④⑧ Hose diameter |
| ②⑩ Passive slide | ⑦③ Depth of centering sleeve hold in adapter plate |
| ②④ Flange | |
| ③① Motor plug | |

Second slide (third slide only on request)

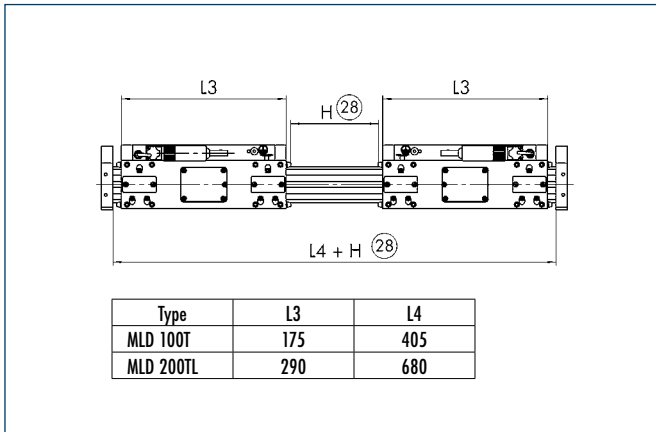

⊗ Total stroke = 2 x stroke per slide

Second passive slide

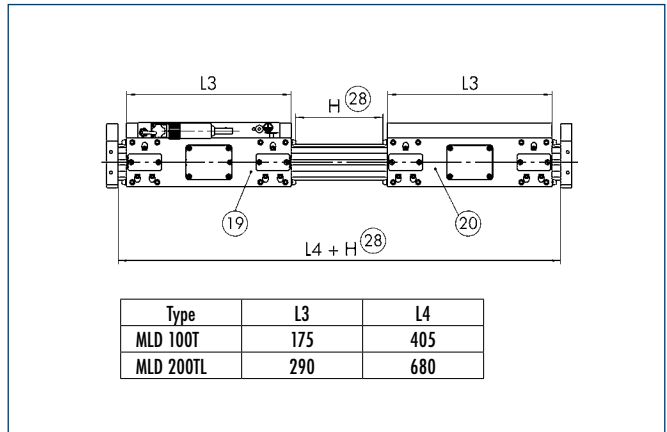

- ①⁹ Powered slide
- ②⁰ Passive slide
- ⊗ Total stroke = 2 x stroke per slide

Wipers

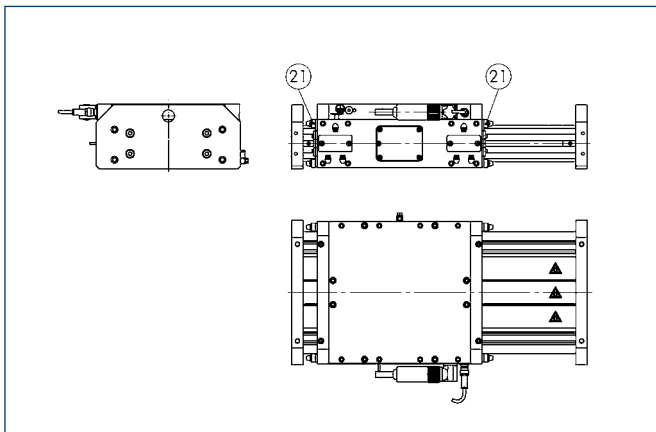

②¹ Wipers

ⓘ Using wipers shortens the useful stroke by 22 mm.

Limit and reference switch with one slide

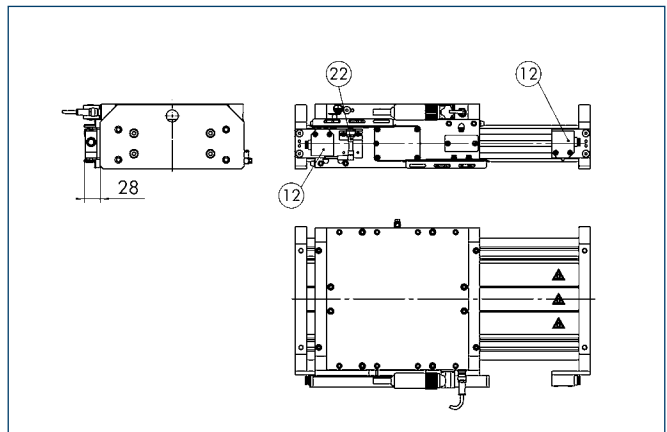

- ①² Mechanical limit switches
- ②² Inductive reference switch

Figure : Left reference switch

Limit and reference switch with two slides

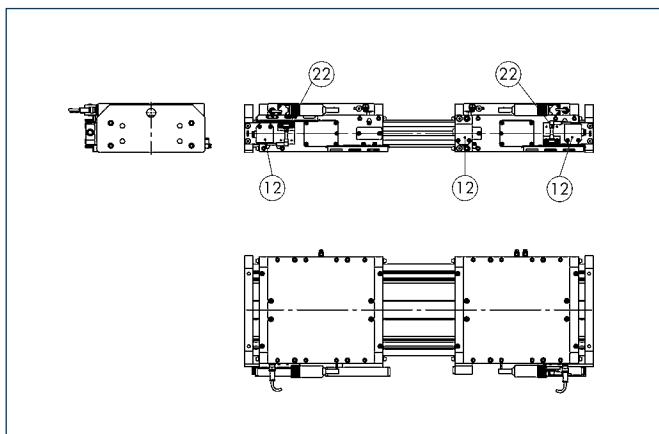

- ⑫ Mechanical limit switches
- ⑳ Inductive reference switch

Shock absorber

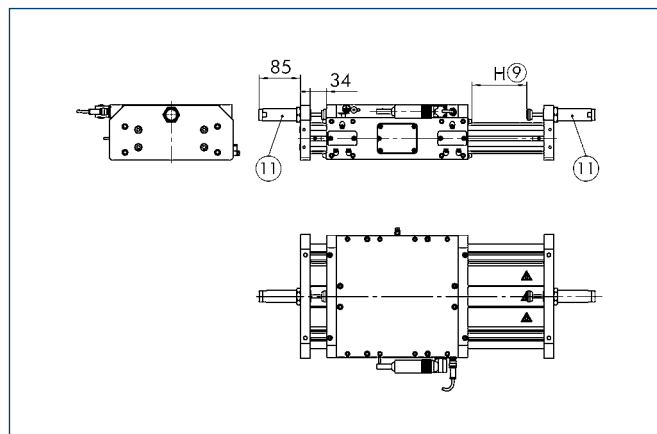

- ⑨ Useful stroke
- ⑪ Shock absorber

① Shock absorbers shorten the useful stroke by 42 mm, as the shock absorbers may not be actuated during axis operation.

Cable track for one motor slide

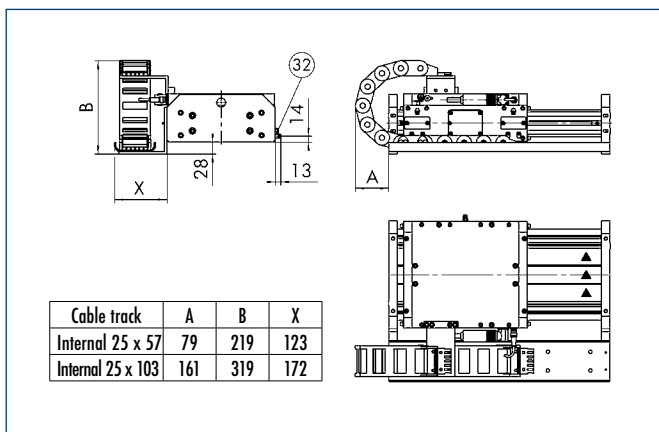
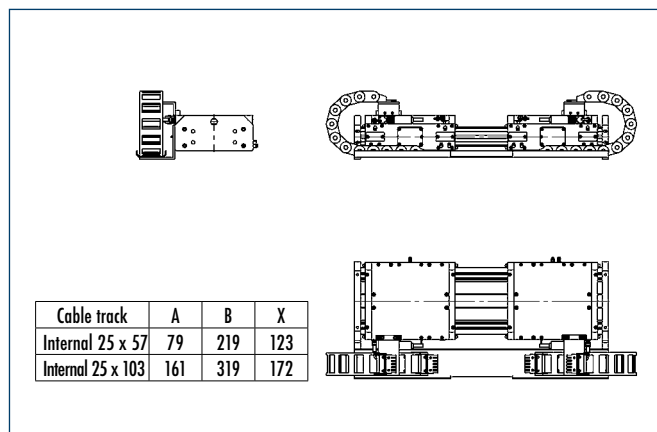

Figure : Cable track to left

XYZ for cable track width 50mm
 XYZ for cable track width 100mm

Cable tracks for two motor slides



XYZ for cable track width 50mm
 XYZ for cable track width 100mm

MLD T (TL) component option codes and ordering

Each axis is supplemented with the required options. Each option is made up of 4 digits. The first two digits indicate the axis type. These are identical for all options for an axis. * The last two digits indicate the selectable options or accessories.

Option digits for axis types:

MLD 200T = 62xx

MLD 300T = 63xx

MLD 200 TL = 64xx

MLD 400 TL = 65xx

MLD 600 TL = 66xx

Version	Description	Option
Active slide	1 slide	xx01
Motor for active slide with plug outlet	Left (completely assembled for INDRADRIIVE)	xx03
	Right (completely assembled for INDRADRIIVE)	xx04
	Left (completely assembled for SINAMICS)	xx58
	Right (completely assembled for SINAMICS)	xx59
Passive slide	1 slide	xx02 (n)**
Holding brake	Mounted in 1 active slide	xx05
Brake valve inc. 10m cable	for 1 slide	xx06
Wipers	mounted on slide	xx07
Reference switch	Inductive reference switches, left	xx08
	Inductive reference switches, right	xx09
	Inductive reference switches for 2 active slides	xx10
Limit switches	Inductive limit switches (right/left)	xx11
	Inductive limit switches for 2 active slides	xx12
	Mechanical limit switches (left/right)	xx13
	Mechanical limit switches for 2 active slides	xx14
Cable track	Narrow, attachment on left	xx15
	Narrow, attachment on right	xx16
	Narrow, for 2 slides left/right	xx17
	Wide, attachment on left	xx18
	Wide, attachment on right	xx19
	Wide, for 2 slides left/right	xx20
Shock absorber	2 units in set	xx21
	3 units in set (2 slides)	xx22
Centering sleeves	D = 9K7 in enclosed pack	xx24 (n)**
	D = 12K7 in enclosed pack	xx25 (n)**
Standard cable sets	INDR. / Basic cable set, 5m straight	xx32
	INDR. / Basic cable set, 10 m straight	xx33
	INDR. / Basic cable set, 15 m straight	xx34
	INDR. / Basic cable set, 20 m straight	xx35
	INDR. / Adv. cable set, 5m straight	xx36
	INDR. / Adv. cable set, 10 m straight	xx37
	INDR. / Adv. cable set, 15 m straight	xx38
	INDR. / Adv. cable set, 20 m straight	xx39
	Sinamics cable set, 5 m	xx40
	Sinamics cable set, 10 m	xx41
	Sinamics cable set, 15 m	xx42
	Sinamics cable set, 20 m	xx43

Measuring system mounting kit	Four-digit code: (e.g. 0132) generated from following code:	Digit 1	Digit 2	Digit 3	Digit 4
		0	1	3	2
Digit 1:	0				
Digit 2: Stroke measuring system type:	1 = Magnetic incremental linear unit 2 = Internal 3 = Absolute MSA 4 = Optical LIA				
Digit 3: Stroke measuring system cable length: (Corresponding to cable set length as standard)	1= 5m 2= 10m 3= 15m 4= 20m				
Digit 4: Drive controller cable version: (Corresponding to cable set version as standard)	1 = Internal 2 = BoschRexroth Indradrive BASIC 3 = BoschRexroth Indradrive ADVANCED 4 = SIEMENS Sinamics				

Sample order

MLD 200T	-	1	-	150	-	nnn	-	6204 - 6211 - 6216 - 6224(6) - 6233 - 0132
Type of axis		Number of active slides		Useful stroke		Total length*** (added by Schunk)		List of required options

* The exception is the stroke measuring system option, which always appears last.

** Options with () contain the quantity of the options specified in brackets. For all options where the number automatically corresponds to the number of active slides, no quantity is specified.

*** Total length = Profile length + 2x end plate
 The only lengths available as the profile length for this axis type - due to the magnet - are xx05, xx20 or xx80mm.
 The profile length is made up of the useful stroke, the total of the slide lengths and the safety reserve typical for the axis (14 mm) and is extended to the next technically feasible length by Schunk project engineers (wipers and shock absorbers are also taken into account). The Schunk useful stroke specification may slightly exceed the required useful stroke due to the permissible profile length. The total length is supplemented.

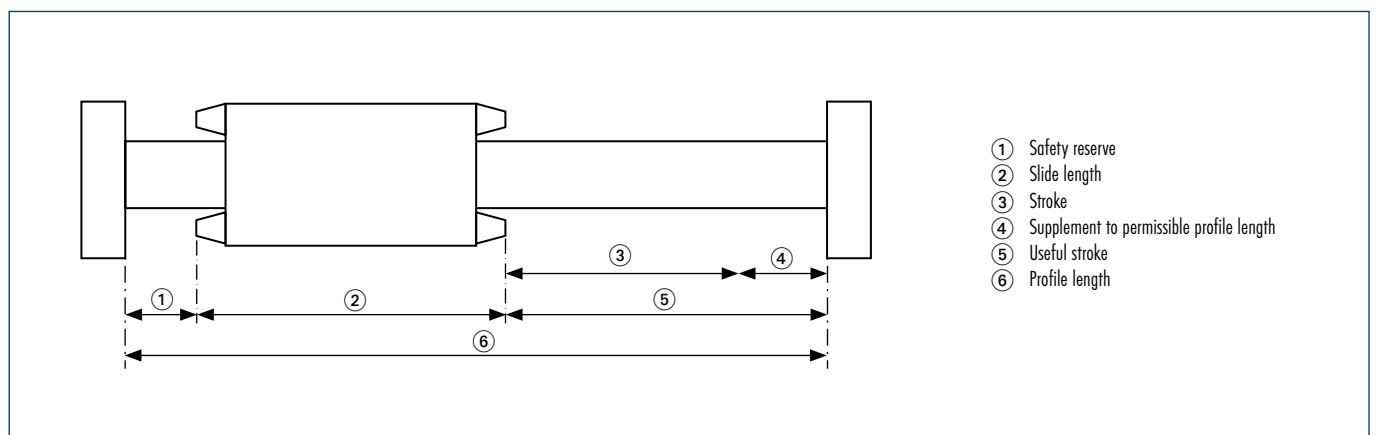

Scope of delivery includes

3-phase, electronically commutated AC synchronous linear motor with primary and secondary part, measuring system, profile guide with guide rollers, slide, profile end plates and with or without Hall sensor depending on the drive concept. Please specify other options when ordering.