

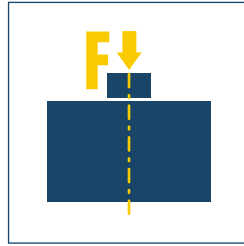

Sizes
8 .. 14



Weight
0.155 kg .. 0.485 kg



Axial force
280 N .. 330 N

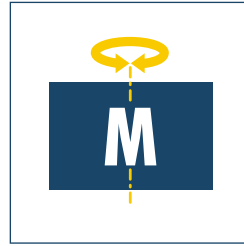

Torque
0.09 Nm .. 1.15 Nm



Bending moment
1.9 Nm .. 3.4 Nm

Application example



Miniature rotary gripping combination for the rapid handling of small components.

1 MRU 8.1-E-2 Rotary Actuator

2 MPG 32 2-Finger Parallel Gripper

Miniature Flat Rotary Actuator

Light, fast, flat rotary unit with numerous options such as flange/PTO shaft, fluid feed-through and more.

Area of application

For use in clean environmental conditions such as assembly or packaging zones and for rapid motion cycles

Your advantages and benefits

Clearly graded series with uniform torque growth

so that for many applications, the correct size is available as a standard product

Always with highly adjustable end positions

for the flexible adjustment of the angle of traverse

Drive with flange shaft or PTO shaft

for easy connection

Fluid feed-through can be used for gases, fluids and vacuum

dispensing with troublesome hoses

End positions free from play

for greater accuracy

Upwards continuation of the series

with the SRU series, ensuring suitability for a broad range of applications



Information about the series

Actuation

Pneumatic, with filtered compressed air (10 µm): Dry, lubricated or non-lubricated
Pressure medium: Required quality class of compressed air according to DIN ISO 8573-1: Quality class 4

Piston and pinion material

Hardened steel (16 MnCr 5)

Housing material

Aluminum press-drawn section

Working principle

Double pinion rack and pinion system

Warranty

24 months

Scope of delivery

Flow control couplings, guide sleeves, O-ring for direct connection, assembly and operating manual with manufacturer's declaration

Sectional diagram

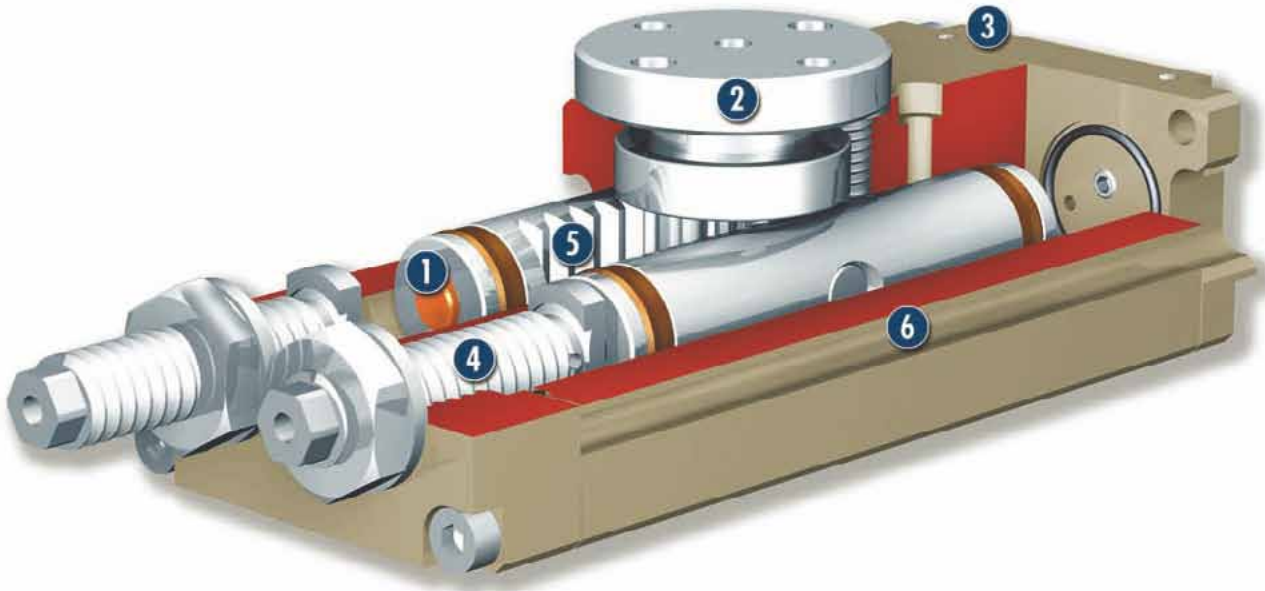

- 1 Damping**
integrated damping with elastomer
- 3 Housing**
weight-reduced through the use of a hard-anodized, high-strength aluminum alloy
- 5 Kinematics**
rack and pinion principle for transforming the drive force into the rotary movement with little play
- 2 Bearing arrangement**
high-precision bearing arrangement through the use of high-quality rolling-contact bearings
- 4 End position**
for a flexible end position
- 6 Monitoring**
position monitoring via solenoid switches

Function description

When subjected to pressure, the two pneumatic pistons move their end faces in a straight line in their bores, turning the pinion by means of the serrations on their sides.

Options and special information

Specialized angles of traverse and swivel ranges are also available on request.

Accessories

Accessories from SCHUNK – the suitable complement for the highest level of functionality, reliability and controlled production of all automation components.

Centering sleeves

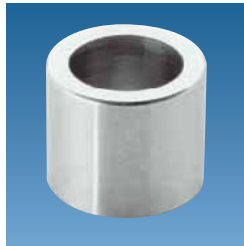

Fittings



MMS magnetic switches



W/WK/KV/GK sensor cables



V sensor distributors

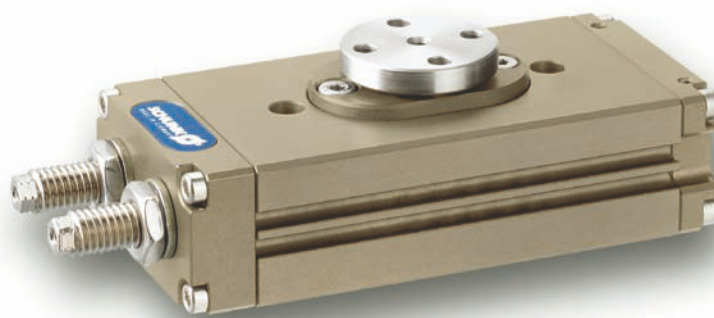

SDV-P pressure maintenance valves



① For the exact size of the required accessories, availability of this size and the designation and ID, please refer to the additional views at the end of the size in question. You will find more detailed information on our accessory range in the „Accessories“ catalog section.

General information on the series

Repeat accuracy

Repeat accuracy is defined as the spread of the limit position after 100 consecutive swiveling cycles.

Pinion position

The position of the pinion is always shown in the drawing in the left-hand end position. From here, the pinion rotates clockwise. The direction of rotation is indicated by the arrow.

Pinion screw connection diagram

Please note that if you wish to set the angle of traverse to less than 90°, the left-hand end stop must generally be screwed in completely. In this way, the screw connection diagram of the left-hand end stop is rotated clockwise by 90° in relation to the drawing, which shows the situation with an angle of traverse of 180°.

Special angles of traverse

Special angles of traverse and swivel ranges are available on request.

Cycle time

Cycle times are purely the times taken by the pinion/flange to turn round the nominal angle of rotation. Valve switching times, hose filling times or SPC reaction times are not included in the above times and must be taken into consideration when determining cycle times.

Layout or checking calculation

For deciding the layout or for checking calculations of rotary modules, we recommend that you use our SSE software, available on CD or from www.schunk.com. A checking calculation of the unit you have chosen is absolutely essential, as otherwise overloading may occur.

Obtain calculation support
from our calculation program
»SSE«
Available on CD-ROM or on the
Internet at www.schunk.com

Application specific parameters

- Torque
- Mass moment of inertia
- Swivel time

Size
(piston diameter)

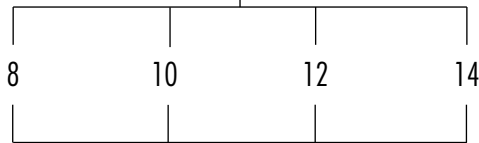

Actuation

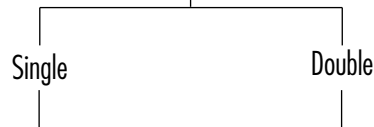

End position damping

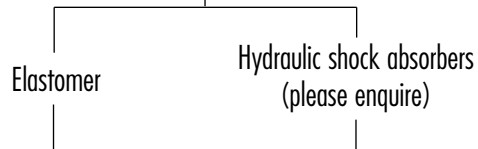

Fluid feed-through



Power output

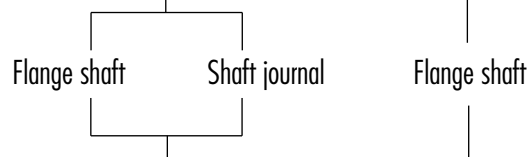

Middle position

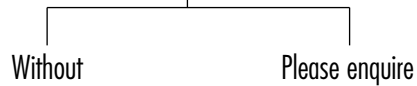

How to order

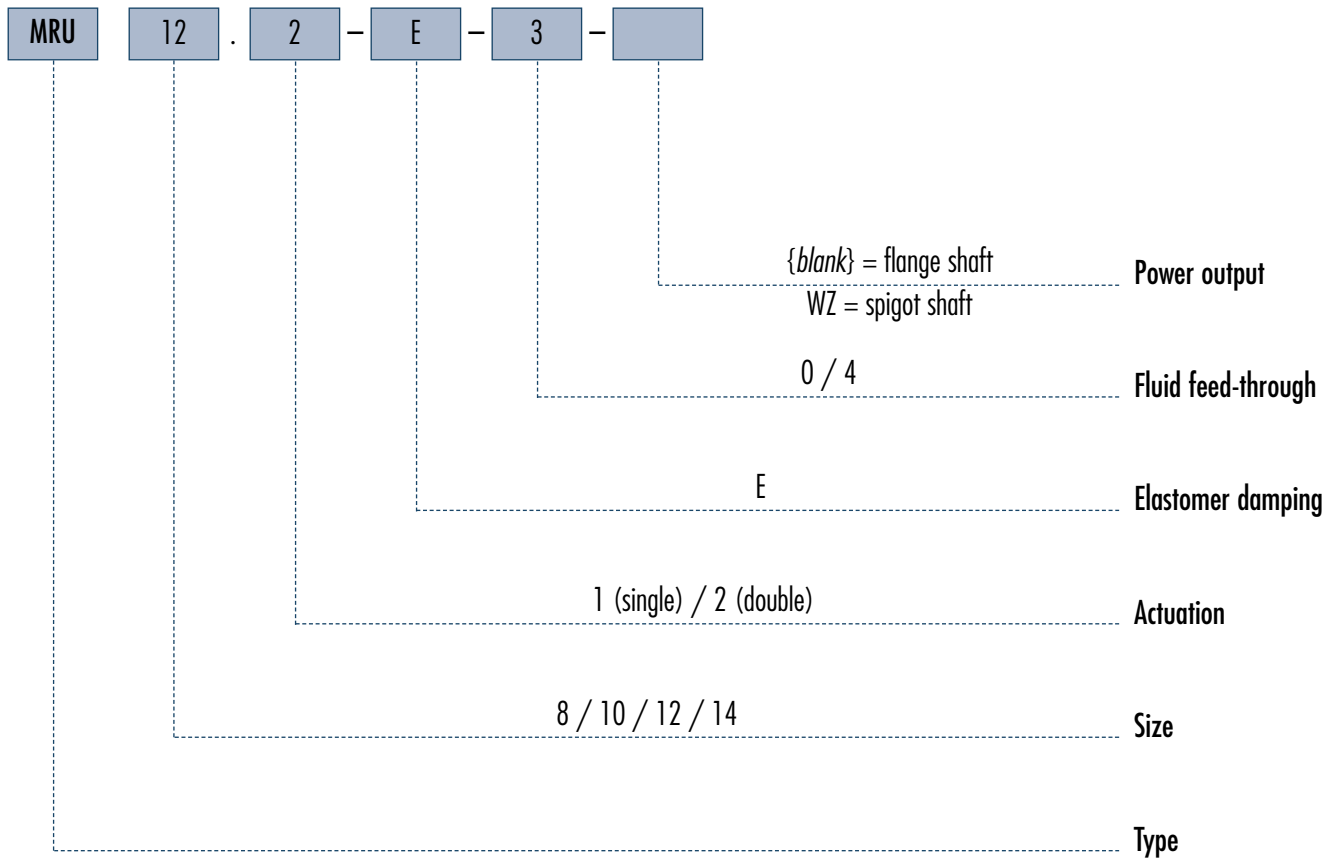

Staggered torque values

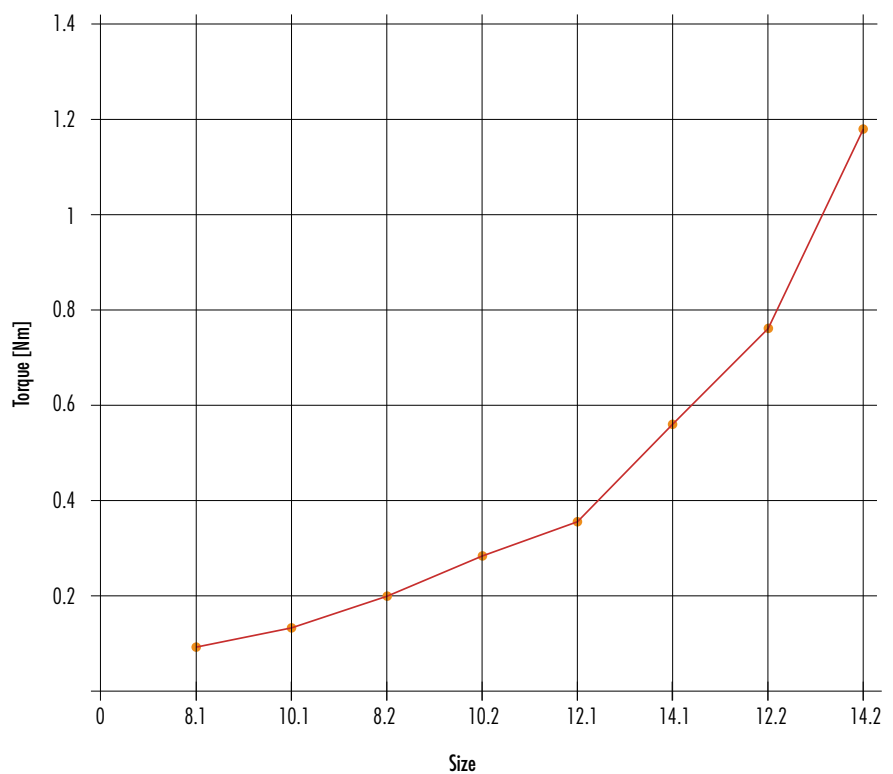



Pinion load

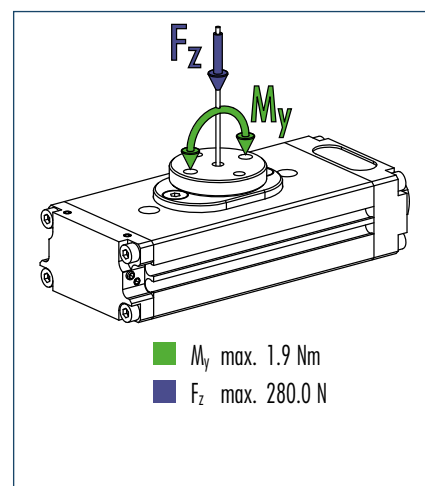

① Moments and forces may occur simultaneously. When using heavy attachments or ones with high mass moments of inertia, the speed must be restricted to ensure that the rotary movement occurs without any hitting or bouncing.

Technical data

Description		MRU 8.1-E-0	MRU 8.2-E-0	MRU 8.2-E-2	MRU 8.1-E-0-WZ	MRU 8.2-E-0-WZ
	ID	0357010	0357110	0357111	0357012	0357112
Torque	[Nm]	0.09	0.2	0.14	0.09	0.2
Rotating angle	[°]	180.0	180.0	180.0	180.0	180.0
Adjustability of end positions	[°]	90.0	90.0	90.0	90.0	90.0
No. of fluid feed-throughs		2				
IP class		65	65	65	65	65
Weight	[kg]	0.16	0.16	0.19	0.155	0.155
Cycle time (1 x nominal angle of rotation) without attached load	[s]	0.04	0.04	0.05	0.04	0.04
Fluid consumption per cycle (2 x nominal angle)	[cm ³]	0.7	1.4	1.4	0.7	1.4
Nominal pressure	[bar]	6.0	6.0	6.0	6.0	6.0
Minimum pressure	[bar]	4.5	4.5	4.5	4.5	4.5
Maximum pressure	[bar]	8.0	8.0	8.0	8.0	8.0
Diameter of connecting hose	[mm]	3.0	3.0	3.0	3.0	3.0
Max. pressure in fluid feed-through	[bar]	8.0				
Min. ambient temperature	[°C]	-10.0	-10.0	-10.0	-10.0	-10.0
Max. ambient temperature	[°C]	90.0	90.0	90.0	90.0	90.0
Repeat accuracy	[°]	0.07	0.07	0.07	0.07	0.07

Main views

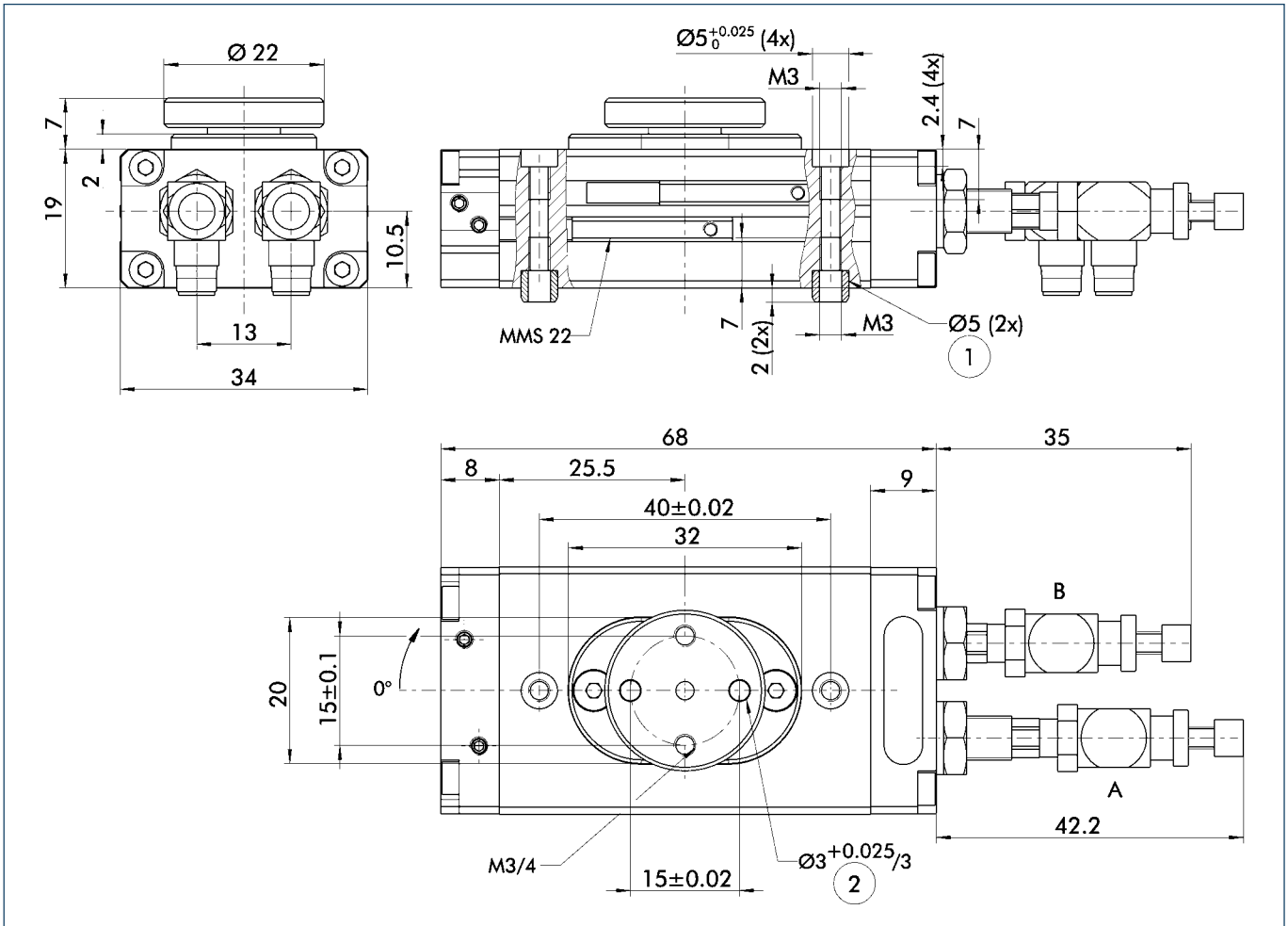

The drawing shows the unit in the basic version, the dimensions do not include the option described below.

- A,a Main/direct connection, clockwise rotary unit
- B,b Main/direct connection, anti-clockwise rotary unit
- ① Rotary unit connection
- ② Attachment connection

① The SDV-P pressure maintenance valve can be used to hold the position upon a loss of pressure (see „Accessories“ catalog section).

Shaft extensions

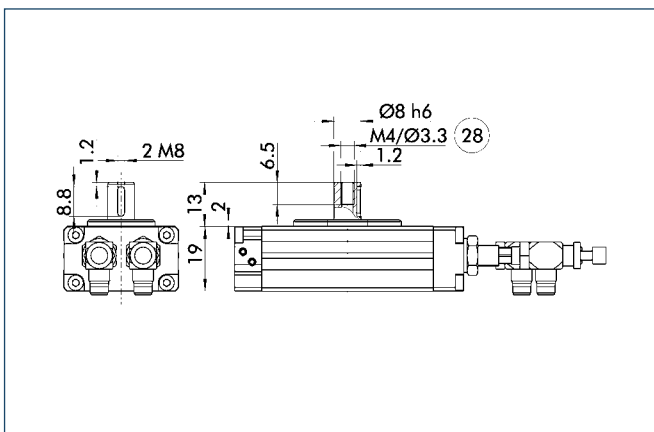

⑳ Through-bore

Different dimensions with the „shaft extension“ option

Fluid feed-through

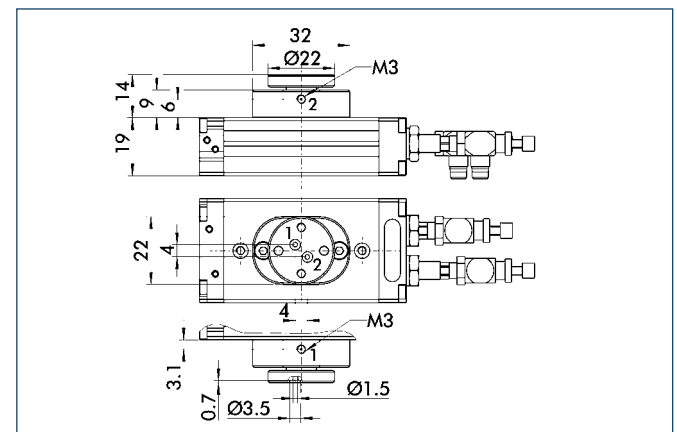

The fluid feed-through enables compressed air or fluids to be conveyed without the need for external hoses.

Sensor system

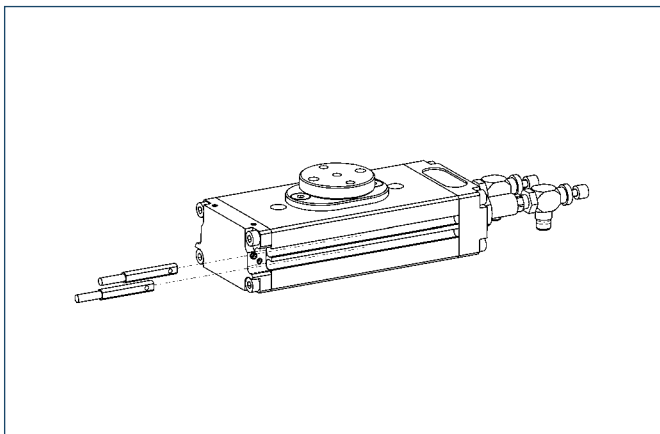

End position monitoring:

Electronic magnetic switches, for mounting in C-slot

Description	ID	Recommended product
MMS 22-S-M5-NPN	0301439	
MMS 22-S-M5-NPN-SA	0301449	
MMS 22-S-M5-PNP	0301438	
MMS 22-S-M5-PNP-SA	0301448	
MMS 22-S-M8-NPN	0301433	
MMS 22-S-M8-NPN-SA	0301443	
MMS 22-S-M8-PNP	0301432	•
MMS 22-S-M8-PNP-SA	0301442	
MMSK 22-S-NPN	0301435	
MMSK 22-S-NPN-SA	0301445	
MMSK 22-S-PNP	0301434	
MMSK 22-S-PNP-SA	0301444	

① Each rotary unit requires the same number of sensors as the positions that are to be monitored, i.e. mostly two, plus extension cable as an option.

Extension cables for proximity switches/magnetic switches

Description	ID
GK 3-M8	0301622
KV 10-M8	0301496
KV 20-M8	0301497
WK 3-M8	0301594
WK 3-M8 NPN	0301602
WK 5-M8	0301502
WK 5-M8 NPN	9641116

① Please note the minimum permitted bending radii for the sensor cables, which are generally 35 mm.



You can find more detailed information and individual parts of the above-mentioned accessories in the „Accessories“ catalog section.