

# LINEAR ACTUATOR

## TYPES

### CLM 25 TO

### CLM 200



Dear Customer,

Congratulations on choosing a SCHUNK product. By choosing SCHUNK, you have opted for the highest precision, top quality and best service.

**You are going to increase the process reliability of your production and achieve best machining results – to the customer's complete satisfaction.**

**SCHUNK products are inspiring.**

Our detailed assembly and operation manual will support you.

Do you have further questions? You may contact us at any time – even after purchase. You can reach us directly at the mentioned addresses in the last chapter of these instructions.

Kindest Regards,

Your SCHUNK GmbH & Co. KG  
Precision Workholding Systems  
Bahnhofstr. 106 - 134  
D-74348 Lauffen/ Neckar

Tel. +49-7133-103-2503  
Fax +49-7133-103-2189  
[automation@de.schunk.com](mailto:automation@de.schunk.com)  
[www.schunk.com](http://www.schunk.com)

Document last updated: 02.05.2007





---

## Contents

<b>1. SAFETY</b> .....	<b>3</b>
1.1. SYMBOL KEY .....	3
1.2. APPROPRIATE USE .....	3
1.3. SAFETY NOTES.....	3
1.4. INDICATIONS TO THE OPERATING MANUAL.....	4
<b>2. WARRANTY</b> .....	<b>4</b>
<b>3. SCOPE OF DELIVERY</b> .....	<b>5</b>
<b>4. TECHNICAL DATA</b> .....	<b>5</b>
<b>5. OPERATING AND ENVIRONMENTAL CONDITIONS</b> .....	<b>5</b>
<b>6. ASSEMBLY AND INSTALLATION</b> .....	<b>5</b>
6.1. DESIGN PRECAUTIONS .....	5
6.2. COMPRESSED AIR SUPPLY .....	6
6.3. SPECIAL CONNECTING MEASURES.....	6
6.4. ASSEMBLY MEASURES.....	6
6.5. MEASURES FOR THE INITIAL OPERATION .....	6
<b>7. HANDLING</b> .....	<b>7</b>
7.1. END POSITION SETS .....	7
7.2. ADJUSTMENT OF LINEAR ACTUATOR STROKE LENGTH.....	8
7.3. DAMPING ADJUSTMENT.....	8
<b>REPAIRS</b> .....	<b>8</b>
<b>RESPONSE TO MALFUNCTIONS</b> .....	<b>9</b>
<b>MAINTENANCE AND CARE</b> .....	<b>9</b>
<b>REPLACEMENT PARTS</b> .....	<b>10</b>
7.4. CLM 25 .....	10
7.5. CLM 50, 100, 200.....	11
<b>8. EC DECLARATION OF INCORPORATION</b> .....	<b>12</b>
<b>9. INDEX</b> .....	<b>13</b>
<b>10. CONTACT</b> .....	<b>14</b>

## 1. Safety

### 1.1. Symbol Key



You will find this symbol wherever **hazards for persons or damage to the product** are possible.



This symbol indicates **important information** on the product or its handling.

### 1.2. Appropriate Use

The unit must only be used within the scope of its technical data. Appropriate use also includes compliance with the conditions the manufacturer has specified for commissioning, assembly, operation, environment and maintenance. Using the unit with disregard to even a minor specification will be deemed inappropriate use. The manufacturer assumes no liability for any injury or damage resulting from inappropriate use.

The linear actuators are manufactured in accordance with the current level of technology and with recognised safety regulations. During their use, however, there may occur risks to life and limb of the user or impairment of the portal actuator and other material assets.

The linear actuators are intended exclusively for the linear movement of service loads in any position that do not react in their manipulation with any risk to persons, property or the environment.

The maximum permissible service loads and forces are given in our standard catalogue. Any usage beyond these definitions is inappropriate.

The manufacturer cannot be held liable for loss or damage arising therefrom. The risk is borne exclusively by the user.

The linear actuator must only be operated by persons that are familiar therewith and that have been instructed in the associated hazards. The relevant accident prevention regulations and the other generally recognised safety and occupational health regulations must be complied with.

### 1.3. Safety Notes

- 1. Responsibility for the compatibility of pneumatic equipment lies with the person who designs the pneumatic system or takes the decision on its specifications.**
  - Since the products specified herein can be used under various operating conditions, their compatibility with the appropriate pneumatic system must be based on specifications and/or tests in order to conform to their requirements.

**2. Machines and equipment operated by pneumatic means may only be used by trained personnel.**



- Compressed air can be hazardous if an operator is not familiar with its use. The assembly, handling or repair of pneumatic systems is to be undertaken by trained and experienced personnel.

**3. Do not carry out maintenance work on machines and equipment and do not attempt to remove components until it has been confirmed that it is safe to do so.**

- Inspection and maintenance of machines and equipment may only be carried out after it has been confirmed that the devices that must be switched off are in a securely deactivated condition.
- If machine parts must be removed, carry out safety precautions as mentioned above. Deactivate the compressed air supply to this machine and release any remaining compressed air from the system.
- Before machines and equipment are switched on again, take measures to ensure that cylinder rods etc. are not pushed outwards. Allow compressed air to enter the system slowly so that counterpressure builds up gradually.

**4. Contact SCHUNK (see chapter 10 page 14) if the product is to be used under one of the following conditions:**

- Conditions and environments that lie outside the stated specifications, or where the product is to be used outdoors.
- Installation in equipment in conjunction with nuclear power, railways, aerospace, vehicles, medical equipment, food and drink, leisure equipment, emergency shutdown circuits, applications in presses or safety equipment.
- Any application that may possibly have negative influences on persons, animals or property and that requires a special safety analysis.

**5. This user manual should always be easily accessible.**

### **1.4. Indications to the operating manual**

This user manual describes linear actuators of series CLM 25, CLM 50, CLM 100 and CLM 200.

All statements in this user manual refer to the types stated above.

## **2. Warranty**

The warranty period is 24 months or 40 million load cycles after delivery date from the factory, assuming use in single-shift operation and that the recommended maintenance and lubrication intervals are respected. Components that come into contact with workpieces, wearing parts, shock absorbers, stop screws and proximity switches are never included in the warranty.

The warranty covers the replacement or repair of defective parts in the manufacturing plant. Further claims are hereby excluded. In this context, please also see our General Terms and Conditions.

### 3. Scope of Delivery

The scope of delivery comprises

- Linear actuator CLM, depending on the version ordered

### 4. Technical Data

Please consult our catalogue for further technical details. The last version is valid in each case. (in accordance with Chapter 2.3 General Terms and Conditions)

The airborne sound emitted from the unit is  $\leq 70\text{dB(A)}$

### 5. Operating and environmental conditions

- Do not use the product in environments comprising corrosive gases, salt water, water or vapours.
- For use in an atmosphere where water drops, oil, sprays etc, occur take appropriate countermeasures in order to ensure protection.
- If electronic end switches are to be used, these should not be used in the presence of strong magnetic fields.
- Please contact SCHUNK (see chapter 10 page 14) if the product is to be used in the presence of strong magnetic fields.
- Do not use the linear actuator in an atmosphere in which it could come into contact with fluids such as oil or water.
- Do not use the linear actuator in an atmosphere in which it could come into direct contact with substances such as powder dust, dust, sprays etc.
- Do not use the linear actuator in an atmosphere in which sources of heat are present.
- Do not subject the linear actuator to excessive vibrations and/or shocks.

### 6. Assembly and Installation

#### 6.1. Design precautions

- A protective guard is recommended in order to minimise the risk of injury.
- Ensure that loose, fixed and/or connected parts are tightened securely.
- Due to the high levels of kinetic energy, shock absorbers must be used.
- Take account of the possibility that the operating pressure may decrease as a result of power failures etc.
- Pay attention to the possibility of the failure of power supplies.
- Mount the compressed air supply in such a way as to prevent sudden extension of the system.
- Pay attention to emergency shutdown facilities.
- Pay attention to what will happen after an emergency stop or abnormal stoppage. Ensure that nobody can be placed at risk or be injured when equipment is restarted.

## 6.2. Compressed air supply

- Use clean compressed air and insert a filter between the supply and the pneumatic system.
- Install a water separator in the pneumatic system.
- Use the product only within the range specified for the medium temperature and ambient temperature.

### Air specification

- dry (free from condensation)
- filtered to 10 microns
- oiled or oil-free

## 6.3. Special connecting measures

- Use connecting pipes of a cross-section that is larger than or identical to that of the connector thread.
- Blow air through the connecting pipes before fitting the devices in order to remove any dust, contaminant or particles.
- Avoid the ingress of sealing material into the pipe network.
- Do not remove pneumatic components from their packaging until shortly before fitting.

## 6.4. Assembly measures

- During the mounting of loads, do not allow the system to be subjected to impermissible forces or moments.
- The flatness of the mounting surfaces must be less than 0.02mm.
- Select the correct means of connection with a load that has its own guidance mechanism and ensure that this is adequately aligned.
- Avoid contact with the linear actuator during operation.
- Select a suitable screw tightening torque for mounting of the linear actuator or loads on the linear actuator in accordance with the generally valid guidelines for screw connections.

## 6.5. Measures for the initial operation



Please read this user manual carefully. Knowledge of this user manual is essential in order to prevent errors and ensure problem-free operation.



**Under no circumstances may linear actuators be operated with oiled air if they are subsequently to be operated with oil-free air.**

- Check the technical specifications.
- Do not use the device until you have checked that it functions correctly taking account of all permissible operating parameters.
- Regulate the operating speed of the cylinder by means of throttle type non-return valves. Increase from the low speed to higher speeds until the required operating speed is reached.

### Selection and dimensioning

- Do not subject the units to loads that exceed the limits of their operating range. If excessive loads are applied, the guidance unit could suffer damage or inaccuracies. The maximum permissible loads are given in our standard catalogue.
- Do not allow the system to experience impermissible forces or shocks.

## 7. Handling

### 7.1. End position sets



The stop screw LMAS-... must only be used for short stroke lengths, low stroke speeds and low kinetic energy levels!

**Shock absorber stops LMST-... should be used as standard.**

The following components are available for limiting of stroke length, damping and detection of end positions:

- LMAS-... (Stop screw)
- LMST-... (Shock absorber stop)
- NI-... (Proximity switch)

The drawing below shows the installation of LMST-.. and NI-...

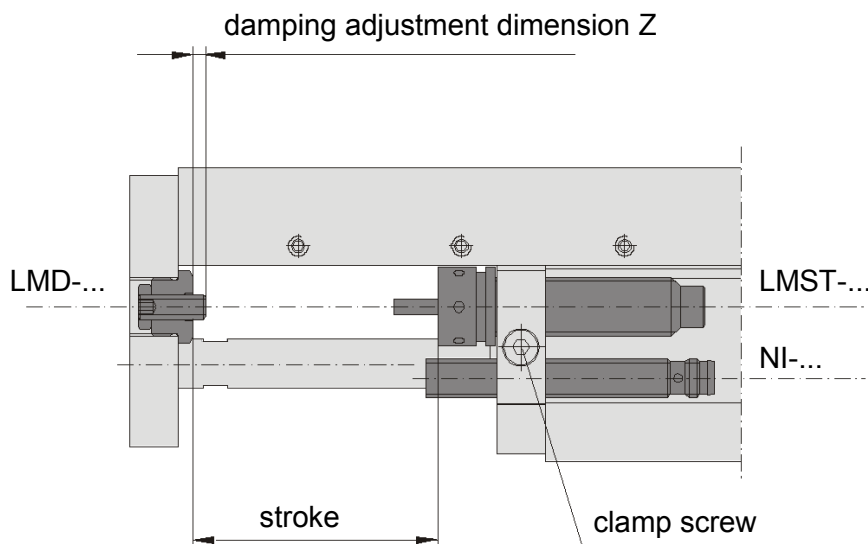

**Figure 1: linear actuator end position sets**

## 7.2. Adjustment of linear actuator stroke length

The stroke length of the linear actuator can be adjusted, after the clamping screw has been loosened, by adjusting the shock absorber stop LMST and proximity switch NI. Once the required stroke length has been set, the clamping mechanism must be tightened again.

### Max. permissible screw tightening torque for grade 8.8:

- CLM 25 1.5Nm
- CLM 50 1.5Nm
- CLM 100 3.0Nm
- CLM 200 5.9Nm

**The maximum possible end position adjustment is given in our standard catalogue.**

## 7.3. Damping adjustment

The adjustment screw of the damper adjustment mechanism LMD can be used to adjust the stroke of the shock absorber and thereby the damping curve to the kinetic energy occurring. The locknut / clamping screw is loosened and the appropriate setting value is adjusted by turning the adjustment screw.

**The maximum and minimum setting values are given in our standard catalogue.**

## Repairs



The repair or elimination of defects on our products by the customer may only be carried out with our explicit written agreement. Any failure to adhere to this principle renders invalid our warranty and liability for any resulting warranty or secondary losses.

Following receipt and examination, all linear actuators of series CLM can be repaired by SCHUNK.

## Response to malfunctions



**Malfunctions that are caused by defective components may only be remedied by replacement of these components.**

Defective components may only be replaced by SCHUNK genuine replacement parts.

Malfunction	Cause	Remedy
<b>Actuator does not move in/out</b>	(1) No compressed air (2) Incorrect pneumatic connections	(1) Check compressed air (2) Check pneumatic elements
<b>End position signal not present</b>	(1) Initiator incorrectly set in relation to stop (2) Initiator defective (3) Broken cable	(1) Readjust initiator (2) Replace initiator (3) Replace initiator cable
<b>Actuator impacts on end positions</b>	(1) Damping incorrectly adjusted (2) Shock absorber defective (3) Ventilation valve defective (4) Stroke speed too high	(1) Adjust stop screw (2) Change shock absorber (3) Check ventilation valve (4) Set ventilation valve
<b>Service load vibrates in end position</b>	(1) Stroke speed too high (2) Inadequate damping (3) Unfavourable installation (4) Unfavourable CLM type	(1) Set ventilation valve (2) Optimise damper stroke (3) Check design (4) Use larger CLM type

## Maintenance and Care



**Under no circumstances may linear actuators be operated with oiled air if they are subsequently to be operated with oil-free air.**

- The integral cylinders are lubricated for life and do not require relubrication. Operation with oiled or oil-free compressed air is permissible without restrictions.
- The crossed roller guidance systems are lubricated for life. It is not therefore necessary to lubricate these again before operation.  
Lubrication or relubrication with rolling bearing grease is recommended after running for approx. 3000km.
- All linear actuators of series CLM are maintenance-free. In order to achieve the maximum operating life, this chapter and chapter 6.2 (at page 6) of this user manual should be observed.
- Apart from normal cleaning of machines, no further maintenance measures are necessary.

## Replacement parts

### 7.4. CLM 25

As a standardised wear part set, a seal set is available under ordering number CLMDI 25. The scope of delivery includes all seals.

In accordance with the section drawing below, all other wear parts and individual parts are available as single items.

**Ordering numbers are as indicated in the following example**

- Part No. 1 CLM 25 - H025 - 01

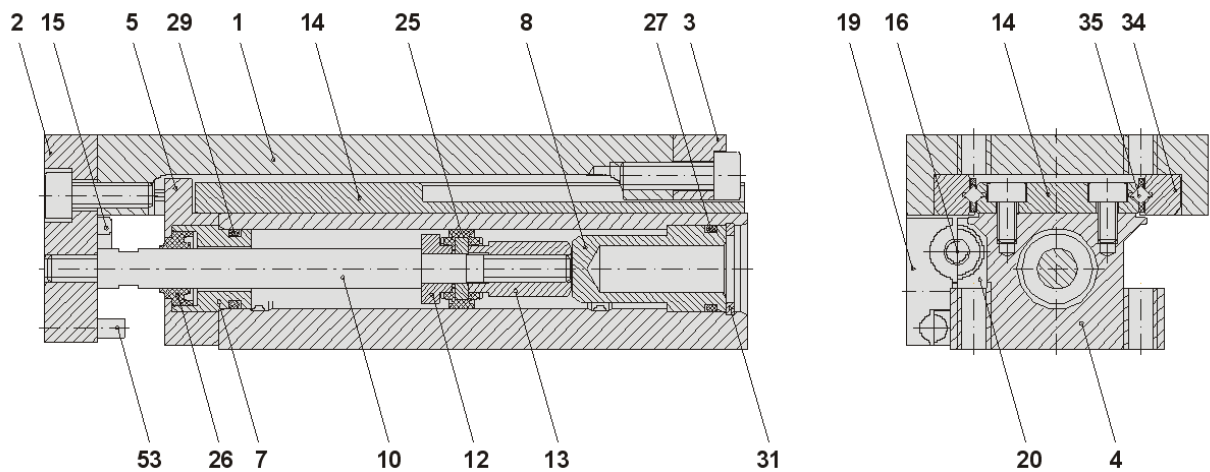

**Figure 2: section drawing CLM 25**

### 7.5. CLM 50, 100, 200

As standardised wear part sets, seal sets are available. The scope of delivery includes all seals. Ordering numbers are as indicated in the following example:

- CLMDI 100 (for linear actuator of series CLM 100)

In accordance with the section drawing below, all other wear parts and individual parts are available as single items.

**Ordering numbers are as indicated in the following example**

- Part No. 1 CLM 100 - H075 - 01

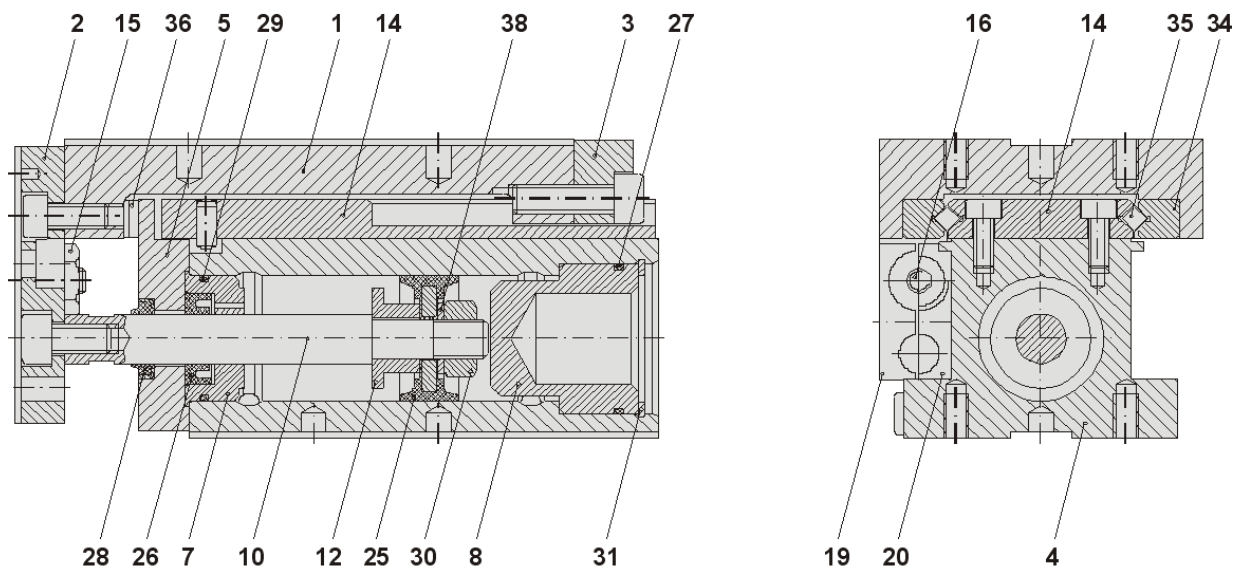

**Figure 3: section drawing CLM 50, 100, 200**

## 8. EC declaration of incorporation

In terms of the EC Machinery Directive 2006/42/EC, annex II B

Manufacturer/  
distributor                      SCHUNK GmbH & Co. KG.  
  Spann- und Greiftechnik  
  Bahnhofstr. 106 – 134  
  74348 Lauffen/Neckar, Germany

We hereby declare that the following product:

**Product designation**    Linear actuator  
**Type designation:**        CLM 25...CLM 200  
**ID number:**                0314035...0314447

meets the applicable basic requirements of the Directive **Machinery (2006/42/EC)**.

The incomplete machine may not be put into operation until conformity of the machine into which the incomplete machine is to be installed with the provisions of the Machinery Directive (2006/42/EC) is confirmed.

Applied harmonized standards, especially:

EN ISO 12100-1                Safety of machines - Basic concepts, general principles for design --  
  Part 1: Basic terminology, methodology  
EN ISO 12100-2                Safety of machines - Basic concepts, general principles for design --  
  Part 2: Technical principles

The manufacturer agrees to forward on demand the special technical documents for the incomplete machine to state offices.

The special technical documents according to Annex VII, Part B, belonging to the incomplete machine have been created.

Person responsible for documentation: Mr. Michael Eckert, Tel.: +49(0)7133/103-2204

Location, date/signature:                      Lauffen, Germany,  
  January 2010    p.p. 

Title of the signatory                              Director for Development

## 9. Index

### A

Adjustment	
damping.....	8
stroke length.....	8
Air specification.....	6
Assembly.....	5
Assembly measures.....	6

### C

Compressed air supply.....	6
connecting measures.....	6

### D

Data	
technical.....	5
Design precautions.....	5
dimensioning.....	7

### E

EC Machine Directive.....	12
end position adjustment.....	8
End position sets.....	7
environmental conditions.....	5

### H

Handling.....	7
---------------	---

### I

Indication	
operating manual.....	4
initial operation.....	6

### L

linear actuator.....	7
----------------------	---

### M

Machine directive	
EC Machine Directive.....	12
Maintenance and Care.....	9
malfunctions.....	9

### O

Operating.....	5
----------------	---

### R

Repairs.....	8
Replacement parts	

CLM 100.....	11
CLM 200.....	11
CLM 25.....	10
CLM 50.....	11
Replacement parts.....	10

### S

Safety notes.....	3
Scope of delivery.....	5
screw tightening torque.....	8
Symbol key.....	3

### T

Terms and conditions	
general.....	4

### U

Use	
appropriate.....	3

### W

Warranty.....	4
---------------	---

## 10. Contact



### GERMANY – HEAD OFFICE

SCHUNK GmbH & Co. KG  
Spann- und Greiftechnik  
Bahnhofstrasse 106 – 134  
D-Lauffen/Neckar  
Tel. +49-7133-103-0  
Fax +49-7133-103-2399  
info@de.schunk.com  
www.schunk.com



### CANADA

SCHUNK Intec Corp.  
190 Britannia Road East,  
Units 23-24  
Mississauga, ON L4Z 1W6  
Tel. +1-905-712-2200  
Fax +1-905-712-2210  
info@ca.schunk.com  
www.ca.schunk.com



### DENMARK

SCHUNK Intec A/S  
Storhaven 7  
7100 Vejle  
Tel. +45-43601339  
Fax +45-43601492  
info@dk.schunk.com  
www.dk.schunk.com



### HUNGARY

SCHUNK Intec Kft.  
Széchenyi út. 70.  
3530 Miskolc  
Tel. +36-46-50900-7  
Fax +36-46-50900-6  
info@hu.schunk.com  
www.hu.schunk.com



### AUSTRIA

SCHUNK Intec GmbH  
Holzbauernstr. 20  
4050 Traun  
Tel. +43-7229-65770-0  
Fax +43-7229-65770-14  
info@at.schunk.com  
www.at.schunk.com



### CHINA

SCHUNK Intec Precision  
Machinery Trading (Shang-  
hai)  
Co., Ltd.  
Xinzhuang Industrial Park  
479 Chundong Road  
Minhang District  
Shanghai 201108  
Tel. +86-21-51760266  
Fax +86-21-51760267  
info@cn.schunk.com  
www.cn.schunk.com



### FRANCE

SCHUNK Intec SARL  
Parc d'Activités des Trois  
Noyers 15, Avenue James de  
Rothschild  
Ferrières-en-Brie  
77614 Marne-la-Vallée  
Cedex 3  
Tel. +33-1-64 66 38 24  
Fax +33-1-64 66 38 23  
info@fr.schunk.com  
www.fr.schunk.com



### INDIA

SCHUNK Intec India Private  
Ltd. # 80 B, Yeswanthpur  
Industrial Suburbs,  
Bangalore 560 022  
Tel. +91-80-40538999  
Fax +91-80-41277363  
info@in.schunk.com  
www.in.schunk.com



### BELGIUM, LUXEMBOURG

SCHUNK Intec N.V./S.A.  
Bedrijvent centrum Regio Aalst  
Industrielaan 4, Zuid III  
9320 Aalst-Erembodegem  
Tel. +32-53-853504  
Fax +32-53-836022  
info@be.schunk.com  
www.be.schunk.com



### CZECH REPUBLIC

SCHUNK Intec s.r.o.  
Drážni 7  
627 00 Brno  
Tel. +420-545 229 095  
Fax +420-545 220 508  
info@cz.schunk.com  
www.cz.schunk.com



### GREAT BRITAIN, IRELAND

SCHUNK Intec Ltd.  
Cromwell Business Centre  
10 Howard Way,  
Interchange Park  
Newport Pagnell MK16 9QS  
Tel. +44-1908-611127  
Fax +44-1908-615525  
info@gb.schunk.com  
www.gb.schunk.com

### ITALY

SCHUNK Intec S.r.l.  
Via Barozzo  
22075 Lurate Caccivio (CO)  
Tel. +39-031-4951311  
Fax +39-031-4951301  
info@it.schunk.com  
www.it.schunk.com

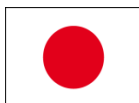

**JAPAN**

SCHUNK Intec K.K.  
45-28 3-Chome Sanno  
Ohta-Ku Tokyo 143-0023  
Tel. +81-33-7743731  
Fax +81-33-7766500  
s-takano@tbk-hand.co.jp  
www.tbk-hand.co.jp



**POLAND**

SCHUNK Intec Sp.z o.o.  
ul. Stoneczna 116 A  
Stara Iwiczna  
05-500 Piaseczno  
Tel. +48-22-7262500  
Fax +48-22-7262525  
info@pl.schunk.com  
www.pl.schunk.com



**SOUTH KOREA**

SCHUNK Intec Korea Ltd.  
# 907 Joongang  
Induspia 2 Bldg.,  
144-5 Sangdaewon-dong  
Jungwon-gu, Seongnam-si  
Kyunggi-do, 462-722  
Tel. +82-31-7376141  
Fax +82-31-7376142  
info@kr.schunk.com  
www.kr.schunk.com



**SWITZERLAND,  
LIECHTENSTEIN**

SCHUNK Intec AG  
Im Ifang 12  
8307 Effretikon  
Tel. +41-523543131  
Fax +41-523543130  
info@ch.schunk.com  
www.ch.schunk.com



**MEXICO, VENEZUELA**

SCHUNK Intec S.A. de C.V.  
Calle Pirineos # 513 Nave 6  
Zona Industrial Benito Juárez  
Santiago de Querétaro,  
Qro. 76120  
Tel. +52-442-211-7800  
Fax +52-442-211-7829  
info@mx.schunk.com  
www.mx.schunk.com



**PORTUGAL**

Sales Representative  
Victor Marques  
Tel. +34-937-556 020  
Fax +34-937-908 692  
Mobil +351-963-786 445  
info@pt.schunk.com  
www.pt.schunk.com



**SPAIN**

SCHUNK Intec S.L.  
Foneria, 27  
08304 Mataró (Barcelona)  
Tel. +34-937 556 020  
Fax +34-937 908 692  
info@es.schunk.com  
www.es.schunk.com



**TURKEY**

SCHUNK Intec  
Bağlama Sistemleri ve  
Otomasyon San. ve Tic. Ltd.  
Şti.  
Küçükyali İş Merkezi  
Girne Mahallesi  
Irmak Sokak, A Blok, No: 9  
34852 Maltepe, İstanbul  
Tel. +90-216-366-2111  
Fax +90-216-366-2277  
info@tr.schunk.com  
www.tr.schunk.com



**NETHERLANDS**

SCHUNK Intec B.V.  
Speldenmakerstraat 3d  
5232 BH 's-Hertogenbosch  
Tel. +31-73-6441779  
Fax +31-73-6448025  
info@nl.schunk.com  
www.nl.schunk.com



**SLOVAKIA**

SCHUNK Intec s.r.o.  
Mostná 62  
949 01 Nitra  
Tel. +421-37-3260610  
Fax +421-37-6421906  
info@sk.schunk.com  
www.sk.schunk.com



**SWEDEN**

SCHUNK Intec AB  
Morabergsvägen 28  
152 42 Södertälje  
Tel. +46-8 554 421 00  
Fax +46-8 554 421 01  
info@se.schunk.com  
www.se.schunk.com



**USA**

SCHUNK Intec Inc.  
211 Kitty Hawk Drive  
Morrisville, NC 27560  
Tel. +1-919-572-2705  
Fax +1-919-572-2818  
info@us.schunk.com  
www.us.schunk.com



**RUSSIA**

OOO SCHUNK Intec  
ul. Samojlovoj, 5, lit. C  
St. Petersburg 192102  
Tel. +7-812-326-78-35  
Fax +7-812-326-78-38  
info@ru.schunk.com  
www.ru.schunk.com

