

MMS, MMS-K

MAGNETIC SWITCH



Dear Customer,

Congratulations on choosing a SCHUNK product. By choosing SCHUNK, you have opted for the highest precision, top quality and best service.

You are going to increase the process reliability of your production and achieve best machining results – to the customer's complete satisfaction.

SCHUNK products are inspiring.

Our detailed assembly and operation manual will support you.

Do you have further questions? You may contact us at any time – even after purchase. You can reach us directly at the mentioned addresses in the last chapter of these instructions.

Kindest Regards,

Your SCHUNK GmbH & Co. KG
Precision Workholding Systems
Bahnhofstr. 106 - 134
D-74348 Lauffen/ Neckar

Tel. +49-7133-103-2503

Fax +49-7133-103-2189

automation@de.schunk.com

www.schunk.com

Date of document: 29.01.2008





Table of contents

1 ELECTRICAL CONNECTION3

2 INSTALLATION AND ADJUSTMENT OF THE SENSOR.....4

3 PROBLEM ANALYSIS6

3.1 GENERAL.....6

3.2 ANALYSIS 1.....6

3.3 ANALYSIS 2.....7

4 TESTS.....7

4.1 SENSOR TEST7

4.2 SENSOR TEST, EXTERNAL.....8

4.3 POWER SUPPLY TEST.....9

5 SOURCES OF INTERFERENCE.....10

6 ACTIONS.....10

7 ENCLOSURE.....11

8 CONTACT.....12

1 Electrical connection



Note

Malfunction of the magnetic switch due to incorrect handling and installation.

- ⇒ Have electrical work carried out only by qualified personnel.
 - ⇒ Do not pull on the cable!
 - ⇒ Do not allow the sensor to hang from the cable!
- ⇒ Do not overtighten the mounting screw or mounting clip!
- ⇒ Avoid contact of the magnetic switch with hard objects and with chemicals, in particular nitric acid, chromic acid and sulphuric acid.
- ⇒ The maximum bending radius of the cable is 15 times the cable diameter.

Type	M8	M12
Connection	<p>Figure 1: M8 connector</p>	<p>Figure 2: M12 connector</p>
	<ul style="list-style-type: none"> ⇒ 1 = + 10 to 30 V DC ⇒ 3 = GND ⇒ 4 = output 	<ul style="list-style-type: none"> ⇒ 1 = + 10 to 30 V DC ⇒ 2 = blind hole ⇒ 3 = GND ⇒ 4 = output ⇒ 5 = blind hole

Type MMS-K

SCHUNK sensors can be ordered in the cable version (MMS-K). You then receive a sensor connected to a 2 m cable. The end of the cable has open wires.

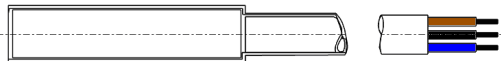

Figure 3: Sensor with wires

Connection	PNP (closer)	NPN (closer)
<p>1 = brown 4 = black 3 = blue</p>		

2 Installation and adjustment of the sensor

Note



⇒ Allen wrenches can affect the switching process of the sensor. Do not use tools made of ferro-magnetic material. Fine positioning of the sensor is achieved by carefully and very gently pushing or pulling.



⇒ The following installation and adjustment example is based on the PGNplus gripper type. The installation and adjustment is similar for all other gripper types. For assistance, refer to the "Accessories" chapter of the operating manual for the respective gripper.

Start

Step 1

⇒ Move gripper to "open" position.

Step 2

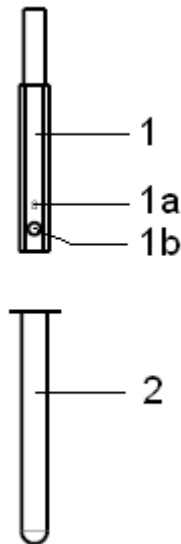

⇒ Insertion of the sensor into the groove.

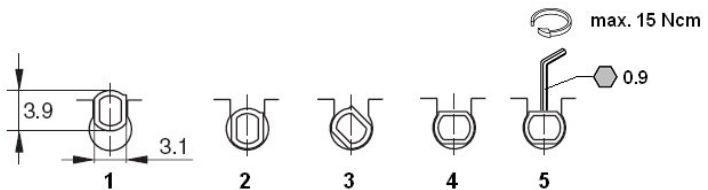
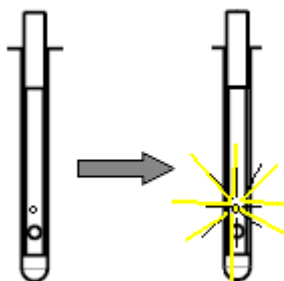

Figure 1 - Insert sensor vertically into the groove from above.
 Figure 2 - Sensor is vertical in the groove.
 Figure 3 - Turn sensor 90° so that the set screw and the LED (1a) of the sensor are visible.
 Figure 4 - Sensor is in the correct position in the groove.
 Figure 5 - Tighten set screw (1b) of the sensor slightly, so that the sensor can no longer turn in the groove but can still be moved easily.

- 1 – magnetic switch
- 1a – set screw
- 1b – LED of the sensor
- 2 – groove on gripper

Step 3



⇒ Push the sensor carefully to the end of the groove.
 ⇒ If the LED of the sensor lights up, the adjustment is complete.
 ⇒ If the LED of the sensor does not light up, then pull the sensor back a little until the LED lights up. (It may be necessary to pull the sensor back a little further in order to increase the switching reliability.)

Step 4

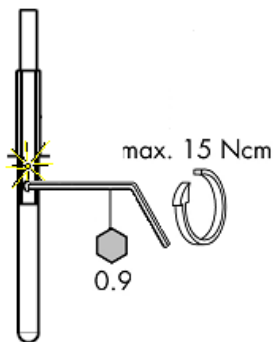

⇒ Carefully fasten the sensor (max. 15 Ncm) with an Allen wrench, size 0.9.

Step 5

⇒ Move gripper to "**closed**" position.

Step 6

⇒ Insert sensor into groove as in **Step 2**.

Step 7

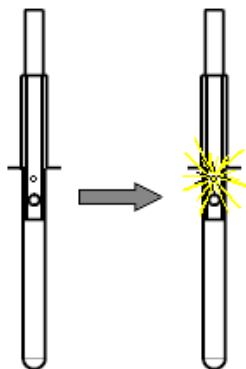

⇒ Carefully push the sensor further in the groove until the LED lights up.
⇒ It may be necessary to push the sensor further in order to increase the switching reliability.

Step 8

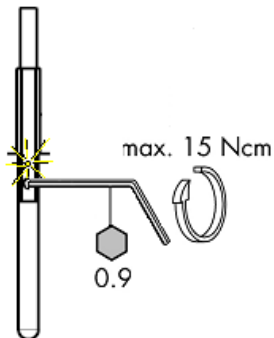

⇒ Carefully fasten the sensor with an Allen wrench, size 0.9.

End

⇒ Check the adjustments with the sensor test on page 7.

3 Problem analysis



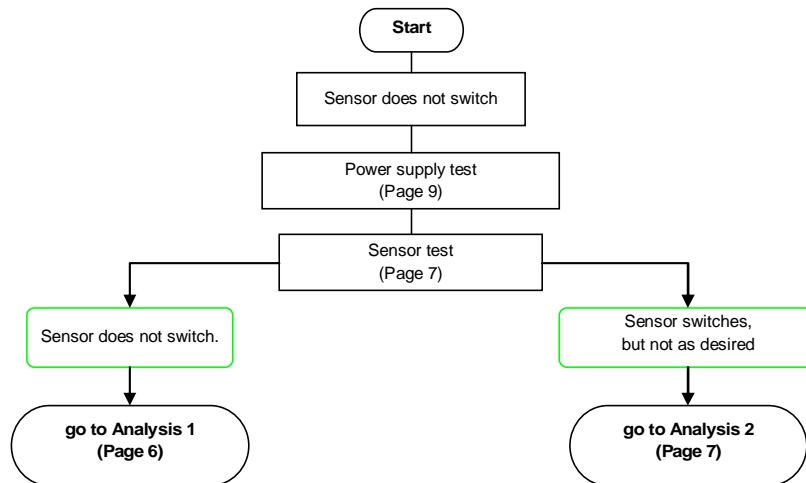

3.1 General

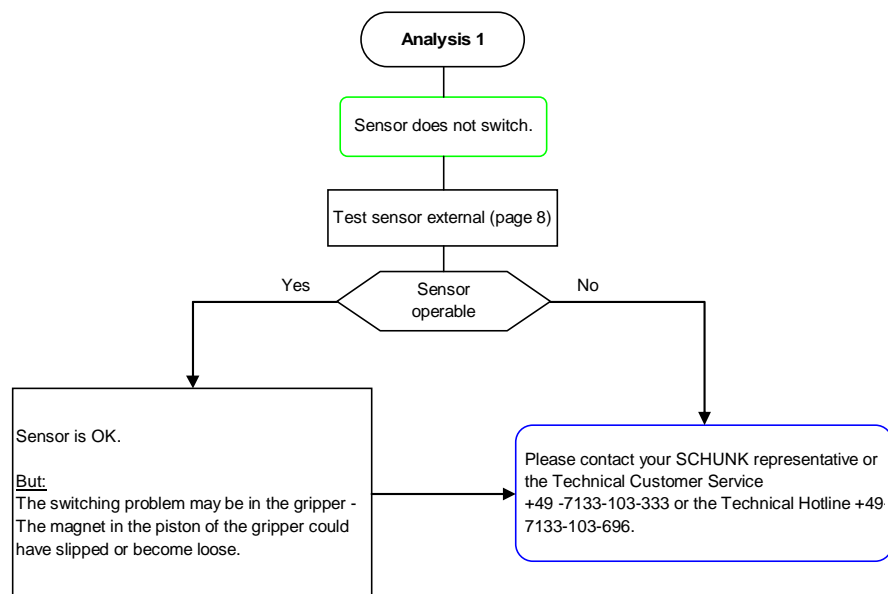

3.2 Analysis 1



Symbols

-  - an action
-  - possible reaction of an action
-  - intermediate result of an action
-  - a result of an action

3.3 Analysis 2

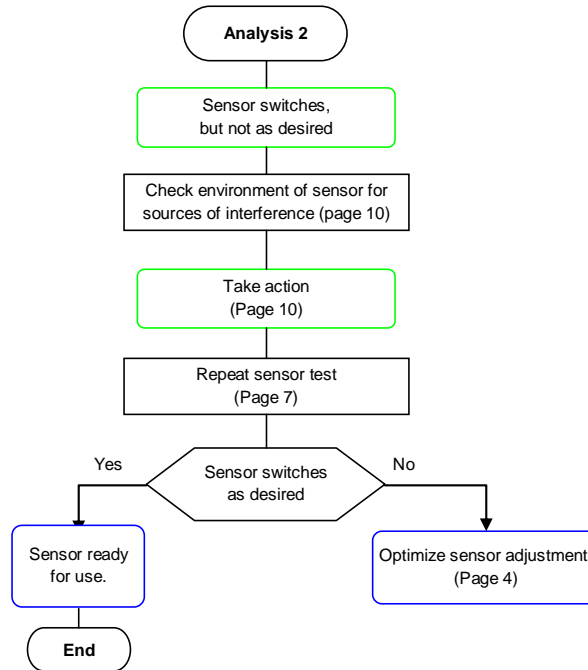

4 Tests

4.1 Sensor test

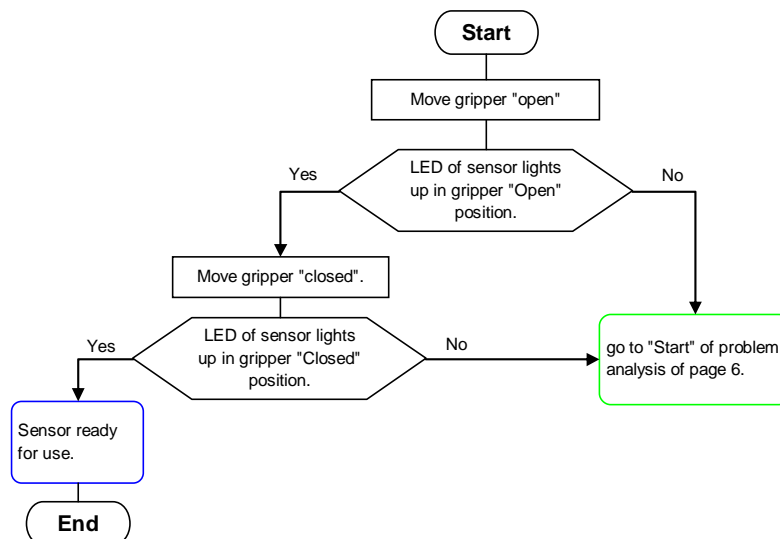

Symbols

- ▭ - an action
- ◇ - possible reaction of an action
- ▭ (green) - intermediate result of an action
- ▭ (blue) - a result of an action

4.2 Sensor test, external

Start ⇒ Sensor should be tested outside of the unit.

Step 1

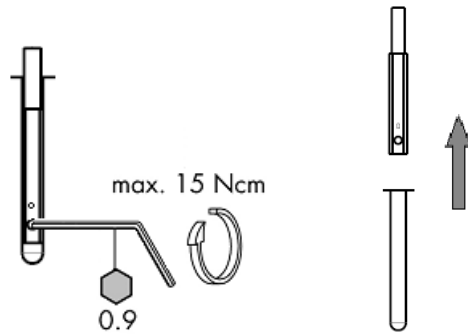

- ⇒ Remove sensor:
- Switch off unit.
 - Loosen set screw of sensor.
 - Pull sensor from the groove.

⇒ The sensor is connected to the power supply (voltage range 10 - 30V DC).

Step 2

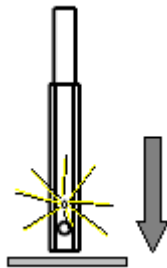

⇒ Move the bottom side of the sensor slowly toward a magnet until it makes contact.

- The sensor is OK if it switches (if the LED lights up).

⇒ If the sensor does not switch: turn the magnet around and move the sensor toward the magnet again.

End ⇒ Go to Analysis 1 (page 6), "Sensor functioning" and follow the corresponding branch of the diagram.



Note

This test can also be conducted with the SST sensor tester (see Enclosure, page 11).

4.3 Power supply test

Measure the voltage at the sensor using the multimeter. Is there sufficient voltage? The voltage must be within the range of 10 - 30V DC.

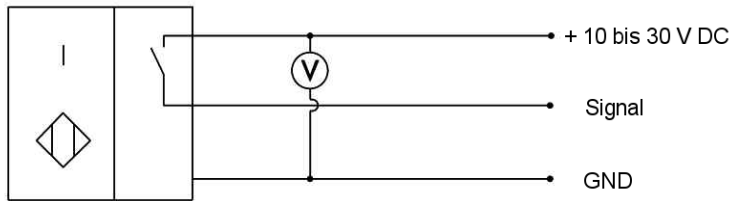

Figure 4: PNP circuit diagram for voltage test



Note

The external sensor test (see Chapter 4.2) can be used to determine whether or not there is a broken cable.

- (1) If the sensor switches (LED lights up) during this test, there is sufficient voltage.
- (2) If the sensor does not switch (LED does not light up), then please contact your SCHUNK representative or our Technology Hotline at +49-7133-103-696.



5 Sources of interference

The functions of sensors can be affected by external magnetic fields in the immediate vicinity. Magnetic fields can be created by:

- motors (coils)
- relays
- linear motors
- identical or similar products
- electric welding
- permanent magnets

Magnetic fields can also be created by self-magnetizing materials. "Self-magnetizing materials" are soft magnetic materials. The main component of such materials is iron, for example.

Soft magnetic materials (examples)	Non soft magnetic materials (examples)
<ul style="list-style-type: none"> - Fe tools (e.g. Allen wrenches, etc.) - Fe workpieces - Fe screws - Fe adapter plates - Liquids with soft magnetic chips 	<ul style="list-style-type: none"> - aluminum - almost all plastics

6 Actions

Description of cause	Source of interference	Action
The sensor is disturbed or affected by external magnetic fields or soft magnetic materials (Fe).	motors (coils) relays linear motors electric welding	Increase the distance between the sensor and these sources of interference (until the sensor switches correctly).
	magnetic workpieces (workpieces made of iron (Fe) or similar materials) magnetized components and tools (adapter plates made of Fe, screws made of Fe, or hexagon socket screws made of Fe, etc.)	Use finger attachments made of aluminum. Use aluminum components, for example V4A screws.
The sensor is affected by another sensor.	identical or similar product	Increase the distance between the sensors to at least 2 mm.
The sensor is affected by accumulations of magnetic chips in the vicinity (in the air gap).	Liquids with magnetic chips or similar materials.	Clean the area directly surrounding the sensor on a regular basis. (The higher the exposure to such liquids, the more frequent the area has to be cleaned.)
The sensor is affected by the gripper immediately next to it.	integrated magnets in the piston of the gripper	Increase the distance to the next gripper to at least 10 mm.

7 Enclosure

Sensor test with the SST sensor tester

The SST enables a simplified testing variant. This sensor testing unit can be used to check the operation of sensors, whether they are already installed or not. The SST has a switch for changing the setting from PNP to NPN. The correct operation of the sensor is indicated by a sound and by an LED.

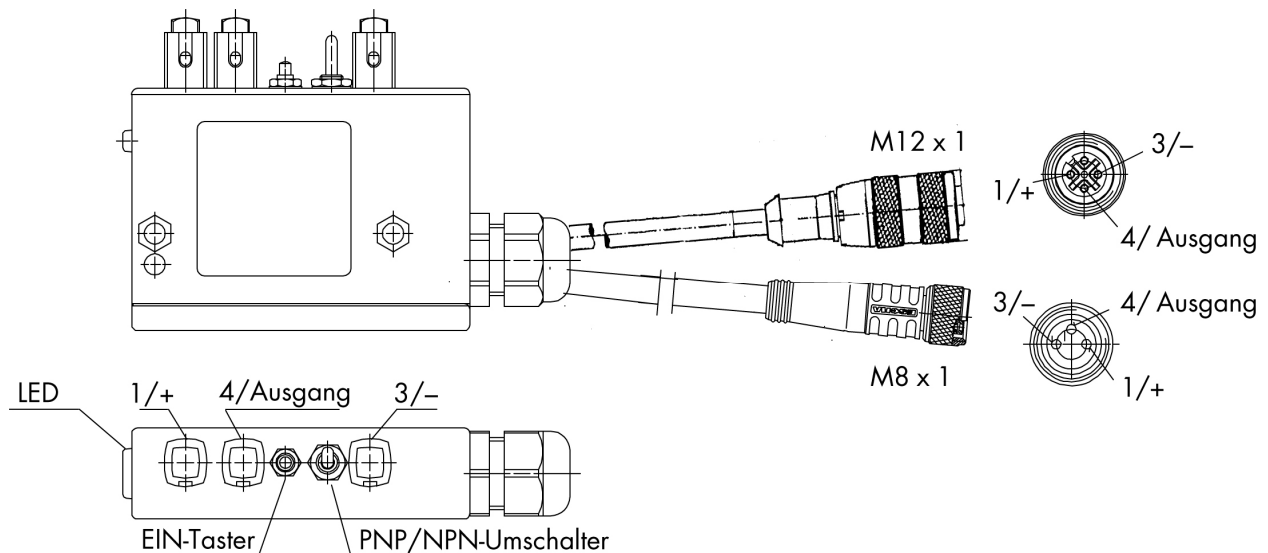

Figure 5: SST

Connection scheme for SST sensor tester:

- ⇒ brown to + (1)
- ⇒ black to output (4)
- ⇒ blue to - (3)

Testing with the SST sensor tester:

- (1) Connect the sensor according to the above connection scheme.
- (2) Press the On button.
- (3) Move the bottom side of the sensor slowly toward a magnet until it makes contact.
 - The sensor is OK if it switches (if the LED lights up).
 - If the sensor does not switch: turn the magnet around and move the sensor toward the magnet again.



Note

If the LED does not light up, move the PNP/NPN switch in the other direction and repeat steps (2-3).

(Towards the sign is the PNP setting and away from the sign, as shown above, is the NPN setting.)

The SST sensor tester is available as an accessory for sensors. For more detailed information, please see our catalog 'Gripper modules / Automation', chapter "Accessories for sensors" on page 954. Further information is also available from your SCHUNK representative.

⇒ You can order the SST sensor tester under order number 0301400.

8 Contact



GERMANY – HEAD OFFICE

SCHUNK GmbH & Co. KG
Spann- und Greiftechnik
Bahnhofstrasse 106 – 134
D-Lauffen/Neckar
Tel. +49-7133-103-0
Fax +49-7133-103-2399
info@de.schunk.com
www.schunk.com



CANADA

SCHUNK Intec Corp.
190 Britannia Road East,
Units 23-24
Mississauga, ON L4Z 1W6
Tel. +1-905-712-2200
Fax +1-905-712-2210
info@ca.schunk.com
www.ca.schunk.com



DENMARK

SCHUNK Intec A/S
Storhaven 7
7100 Vejle
Tel. +45-43601339
Fax +45-43601492
info@dk.schunk.com
www.dk.schunk.com



HUNGARY

SCHUNK Intec Kft.
Széchenyi út. 70.
3530 Miskolc
Tel. +36-46-50900-7
Fax +36-46-50900-6
info@hu.schunk.com
www.hu.schunk.com



AUSTRIA

SCHUNK Intec GmbH
Holzbauernstr. 20
4050 Traun
Tel. +43-7229-65770-0
Fax +43-7229-65770-14
info@at.schunk.com
www.at.schunk.com



CHINA

SCHUNK GmbH & Co.KG
Shanghai
Representative Office
777 Zhao Jia Bang Road
Pine City Hotel, Room 923
Xuhui District
Shanghai 200032
Tel. +86-21-64433177
Fax +86-21-64431922
info@cn.schunk.com
www.cn.schunk.com



FRANCE

SCHUNK Intec SARL
Parc d'Activités des Trois
Noyers 15, Avenue James de
Rothschild
Ferrières-en-Brie
77614 Marne-la-Vallée
Cedex 3
Tel. +33-1-64 66 38 24
Fax +33-1-64 66 38 23
info@fr.schunk.com
www.fr.schunk.com



INDIA

SCHUNK India Branch Office
80 B, Yeswanthpur
Industrial Suburbs,
Bangalore 560 022
Tel. +91-80-41277361
Fax +91-80-41277363
info@in.schunk.com
www.in.schunk.com



BELGIUM, LUXEMBOURG

SCHUNK Intec N.V./S.A.
Bedrijvent centrum Regio Aalst
Industrielaan 4, Zuid III
9320 Aalst-Erembodegem
Tel. +32-53-853504
Fax +32-53-836022
info@be.schunk.com
www.be.schunk.com



CZECH REPUBLIC

SCHUNK Intec s.r.o.
Ernsta Macha 1
643 00 Brno
Tel. +420-545 229 095
Fax +420-545 220 508
info@cz.schunk.com
www.cz.schunk.com



GREAT BRITAIN, IRELAND

SCHUNK Intec Ltd.
Cromwell Business Centre
10 Howard Way,
Interchange Park
Newport Pagnell MK16 9QS
Tel. +44-1908-611127
Fax +44-1908-615525
info@gb.schunk.com
www.gb.schunk.com



ITALY

SCHUNK Intec S.r.l.
Via Barozzo
22075 Lurate Caccivio (CO)
Tel. +39-031-4951311
Fax +39-031-4951301
info@it.schunk.com
www.it.schunk.com

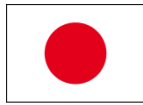

JAPAN

SCHUNK Intec K.K.
45-28 3-Chome Sanno
Ohta-Ku Tokyo 143-0023
Tel. +81-33-7743731
Fax +81-33-7766500
s-takano@tbk-hand.co.jp
www.tbk-hand.co.jp



POLAND

SCHUNK Intec Sp.z o.o.
Stara Iwiczna,
ul. Sloneczna 116 A
05-500 Piaseczno
Tel. +48-22-7262500
Fax +48-22-7262525
info@pl.schunk.com
www.pl.schunk.com



SOUTH KOREA

SCHUNK Intec Korea Ltd.
907 Joongang
Induspia 2 Bldg.,
144-5 Sangdaewon-dong
Jungwon-gu, Seongnam-si
Kyunggi-do, 462-722
Tel. +82-31-7376141
Fax +82-31-7376142
info@kr.schunk.com
www.kr.schunk.com



**SWITZERLAND,
LIECHTENSTEIN**

SCHUNK Intec AG
Soodring 19
8134 Adliswil 2
Tel. +41-44-7102171
Fax +41-44-7102279
info@ch.schunk.com
www.ch.schunk.com



MEXICO, VENEZUELA

SCHUNK Intec S.A. de C.V.
Av. Luis Vega y Monroy # 332
Frac. Plazas de Sol
Santiago de Querétaro,
Qro. 76099
Tel. +52-442-223-6525
Fax +52-442-223-7665
info@mx.schunk.com
www.mx.schunk.com



PORTUGAL

Sales Representative
Victor Marques
Tel. +34-937-556 020
Fax +34-937-908 692
Mobil +351-963-786 445
info@pt.schunk.com
www.pt.schunk.com



SPAIN

SCHUNK Intec S.L.
Foneria, 27
08304 Mataró (Barcelona)
Tel. +34-937 556 020
Fax +34-937 908 692
info@es.schunk.com
www.es.schunk.com



TURKEY

SCHUNK Intec
Bağlama Sistemleri ve
Otomasyon San. ve Tic. Ltd.
Şti.
Küçükyali İş Merkezi
Girne Mahallesi
Irmak Sodak, A Blok, No: 9
34852 Maltepe, Istanbul
Tel. +90-216-366-2111
Fax +90-216-366-2277
info@tr.schunk.com
www.tr.schunk.com



NETHERLANDS

SCHUNK Intec B.V.
Speldenmakerstraat 3d
5232 BH 's-Hertogenbosch
Tel. +31-73-6441779
Fax +31-73-6448025
info@nl.schunk.com
www.nl.schunk.com



SLOVAKIA

SCHUNK Intec s.r.o.
Mostná 62
919 01 Nitra
Tel. +421-37-3260610
Fax +421-37-6421906
info@sk.schunk.com
www.sk.schunk.com



SWEDEN

SCHUNK Intec AB
Morabergsvägen 28
152 42 Södertälje
Tel. +46-8 554 421 00
Fax +46-8 554 421 01
info@se.schunk.com
www.se.schunk.com



USA

SCHUNK Intec Inc.
211 Kitty Hawk Drive
Morrisville, NC 27560
Tel. +1-919-572-2705
Fax +1-919-572-2818
info@us.schunk.com
www.us.schunk.com