

Fluidic Monitoring System

Pneumatic monitoring for three positions. For systems that can be monitored by means of conventional sensors.



Function description

The PA3 returns the information “open”, “gripped” or “closed” to the controller via a single, additional pneumatic line. The pneumatic actuator only has to be modified with two pneumatic connections for this purpose. The PA3 is started up via a push button switch and a potentiometer. The unit is automatically taught during a set-up cycle.

Your advantages and benefits

Position scan without electric sensors

for diverse applications in new environments

An additional pneumatic line as an information hose

therefore only slight modification of the gripper necessary, also possible as retrofitting of existing components

Simple start-up

via button and potentiometer

Self teach-in function

for automatic teaching of the monitoring system during the set-up cycle

Application example

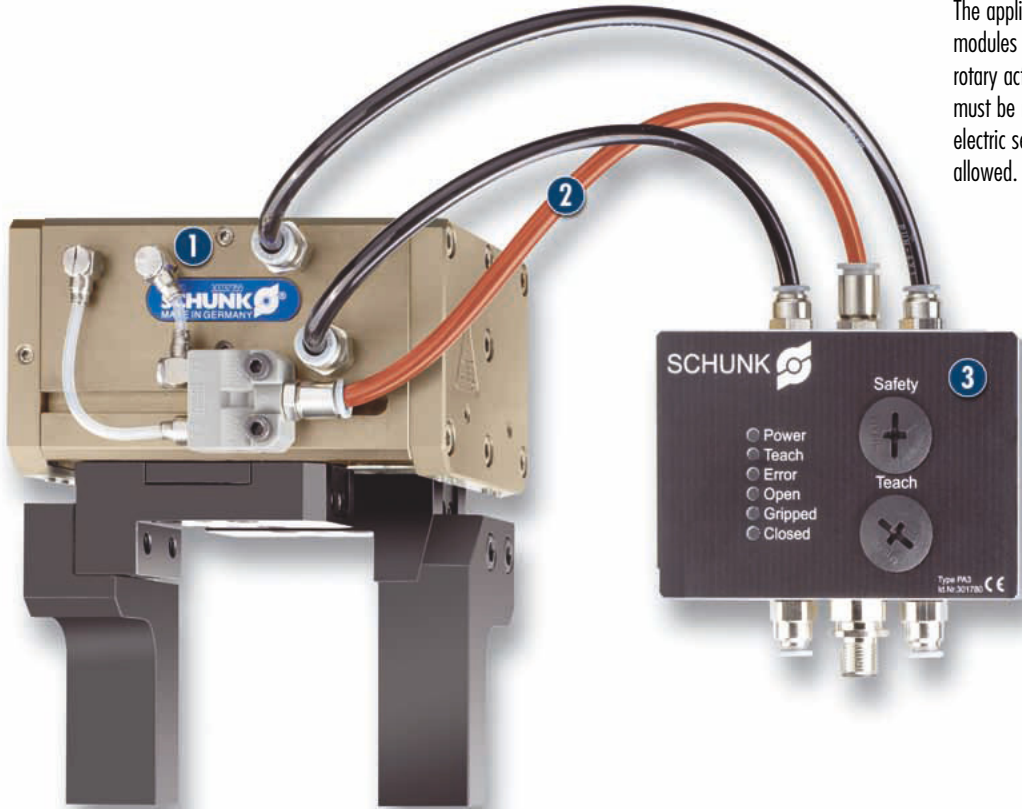

Area of application

The applications range from pneumatic gripper modules to pneumatic actuators, such as cylinders or rotary actuators. For example, when gripper modules must be monitored in places that are not accessible by electric sensors or where electric sensors are not allowed.

1 2-Finger Long-stroke Gripper
PFH 30
with special bores for the PA3

2 Additional information source

3 PA3-Electronic system

General information

Power supply for electronics
24 V DC

Warranty
24 months





Technical data

Description	PA3
ID	0301780
IP class	67
Type of voltage	DC
Nominal voltage [V]	24
Min. voltage [V]	21.6
Max. voltage [V]	26.4
Nominal power current [mA]	30
Maximum current [mA]	130
Weight [kg]	1.13
Hose connection [mm]	6
Min. nominal pressure [bar]	3
Max. pressure [bar]	10
Permissible media	compressed air
Typical switching time [s]	1

Main view

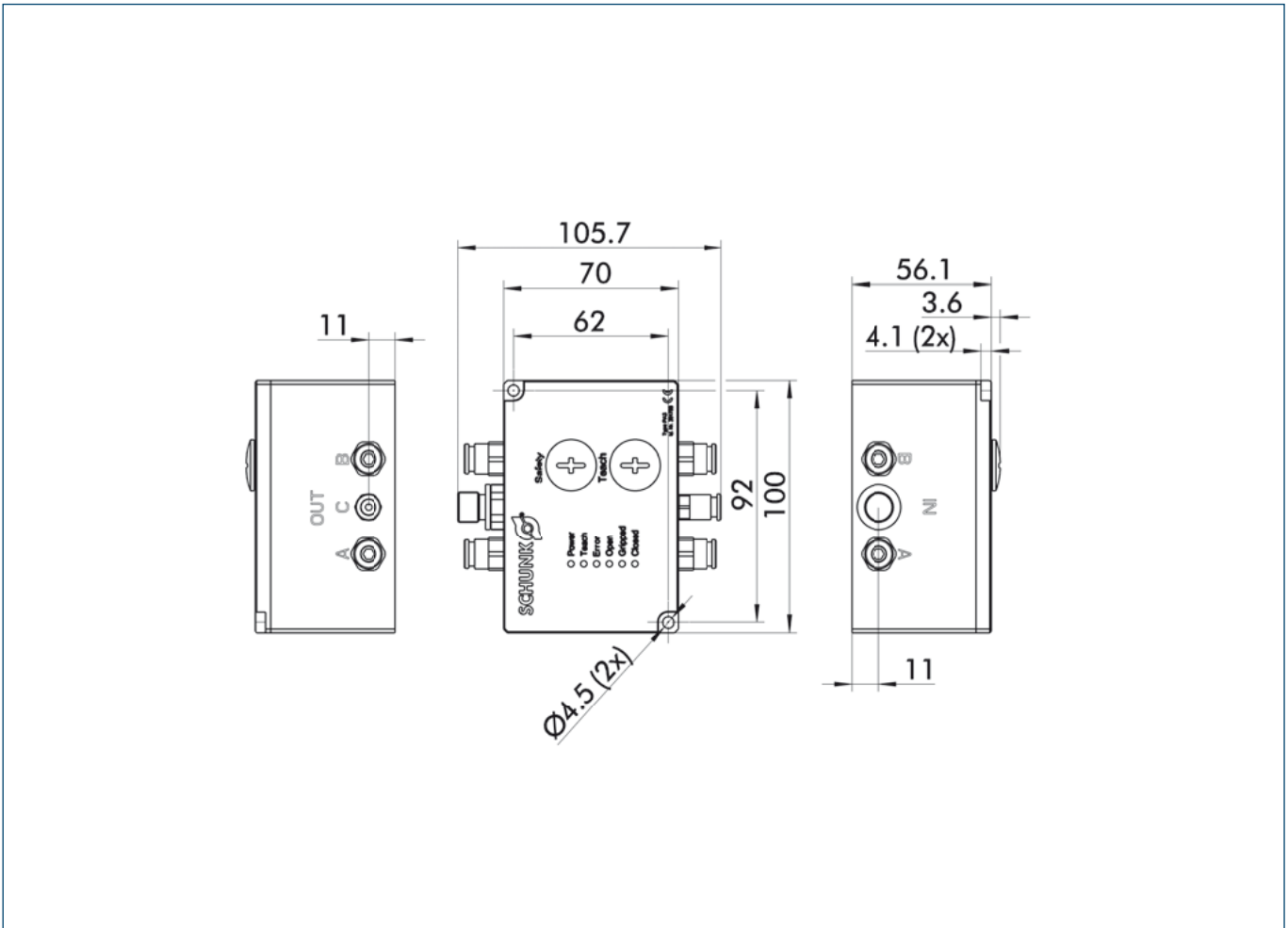

AND valve

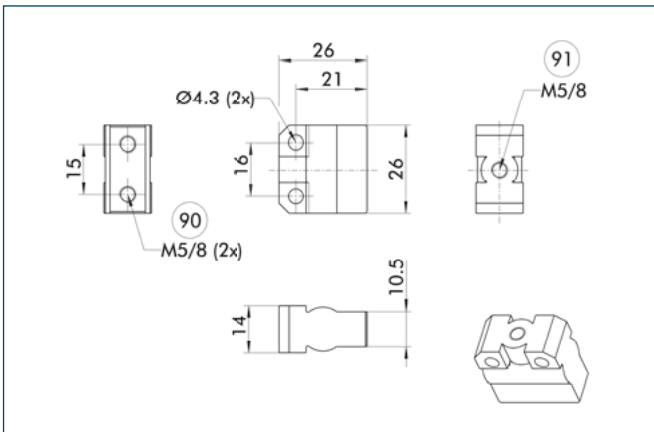

- 90 Input
- 91 Output

Two additional bore holes in the piston chamber of the monitored components are connected with the AND valve. The resulting pressure signal is sent to the PA3.