

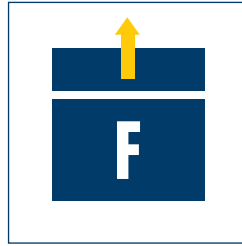

Sizes
30 .. 48



Weight
0.17 kg .. 1.56 kg
0.37 lbs .. 3.44 lbs



Advancing force
83 N .. 265 N
18.7 lbf .. 60 lbf



Stroke
15 mm .. 60 mm
0.591 in .. 2.362 in



Bending moment
5 Nm .. 20 Nm
3.7 lbf ft .. 14.8 lbf ft

Application example

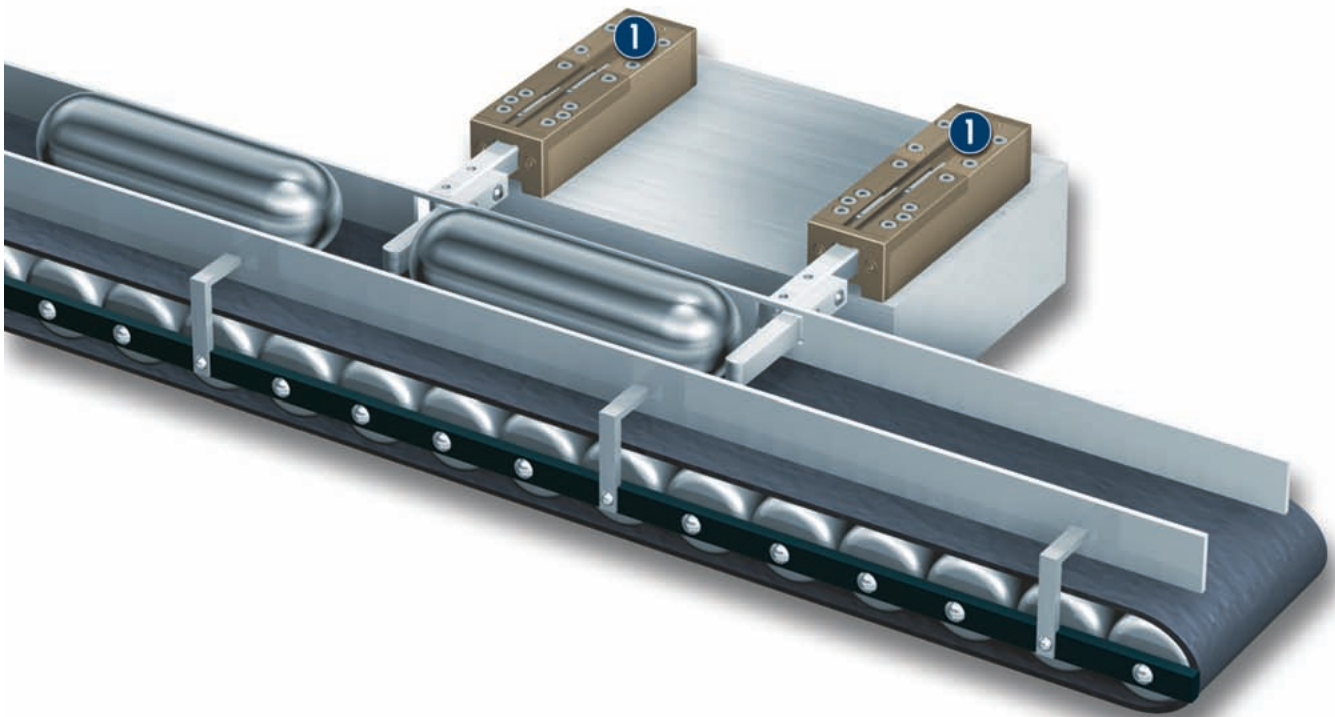

Separation of cylindrical blanks
for individual feed to the machining station

1 PES 38 Single Escapement

Single Escapement

Single escapement with integrated magnetic switch monitoring, can also be used as a stop cylinder

Area of application

For use for the individual feeding of bulk material or magazined workpieces, or for use as a stop cylinder for the temporary stoppage of pallets on conveyor systems.

Your advantages and benefits

Attached to the housing

allowing universal mounting of the escapement

Threads on four surfaces of the base finger

for the flexible attachment of the top fingers

Diverse options

(dust protection, spring lock, stopp cylinder) for optimization to suit precisely your requirements.



Information about the series

Working principle

Conventional, pneumatic round piston drive, directly connected to a square base finger

Housing material

Aluminum, hard-anodized

Base finger material

Polished stainless steel

Warranty

24 months

Actuation

Pneumatic, with filtered compressed air (10 µm): Dry, lubricated or non-lubricated
Pressure medium: Required quality class of compressed air according to DIN ISO 8573-1: Quality class 4

Scope of delivery

Centering sleeves, T-slots, assembly and operating manual with manufacturer's declaration



Sectional diagram

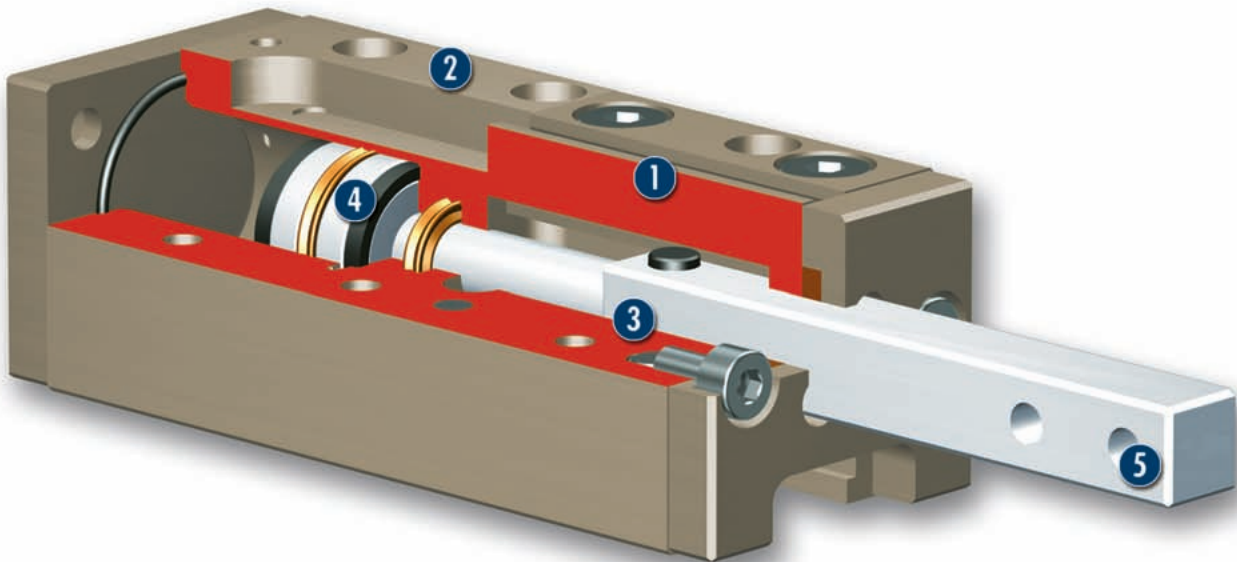

- 1 Monitoring**
Integrated end position monitoring with magnetic switches
- 3 Guidance**
Maximum precision and load-bearing capacity through guidance with minimum play
- 5 Mounting options**
for universal finger assembly
- 2 Housing**
Weight-reduced through the use of a hard-anodized, high-strength aluminum alloy
- 4 Drive**
Pneumatic, powerful and easy to handle

Function description

The pneumatic piston is moved by compressed air. This causes the square rod to extend and retract. The product-specific top finger mounted on the square rod separates the workpieces that are fed to it. When employed as a pallet stopper, the square rod itself acts as the stop.

Options and special information

Dust-protection version

Dust proof, increased degree of protection against the ingress of substances, for use in dusty environments

Stop cylinder version

For the temporary stoppage of pallets on conveyor systems

Accessories

SCHUNK accessories – the suitable complement for the highest level of functionality, reliability and controlled production of all automation modules.

Centering sleeves



Fittings



MMS magnetic switch



W/WK/KV/GK sensor cables



V sensor distributors



SDV-P pressure maintenance valves



① For the exact size of the required accessories, availability of this size and the designation and ID, please refer to the additional views at the end of the size in question. You can find more detailed information on our accessory range in the "Accessories" catalog section.

General information on the series

Using the PES as an escapement

When the PES is used as an escapement, as a rule a workpiece-specific top finger is mounted.

Using the PES as a stopper

When the PES is used as a stopper, the PES piston rod itself has contact with the pallet that needs to be stopped. No top fingers may be mounted.

T-slot mounting

Alternatively, the PES can also be mounted using the groove on the rear and the supplied T-slots.

Finger length L

The finger length L is measured from the upper edge of the housing to the point of contact of the workpiece/pallet in the direction of motion of the piston rod.





Permitted weight/speed

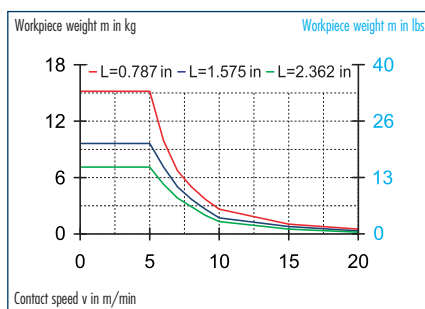

Permitted weight/speed

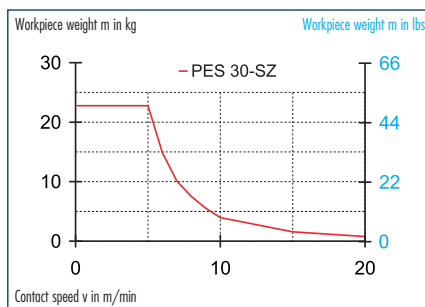

Finger load

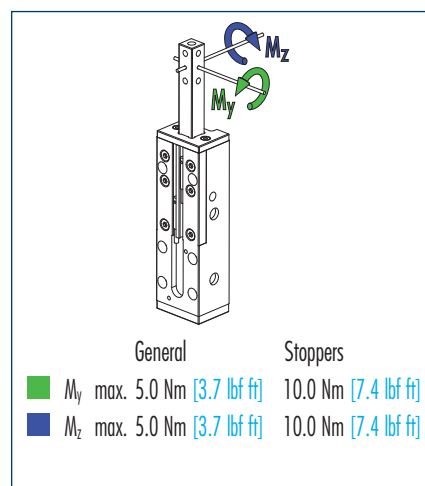

① Moments apply from the upper edge of the housing and may occur simultaneously. Leverages of forces are measured from the upper edge of the housing.

Technical data

Description		PES 30	PES 30-FS	PES 30-SD	PES 30-FS-SD	PES 30-SZ
	ID	0302650	0302651	0302300	0302301	0302652
Max. bending moment	Nm [lbf ft]	5.0 [3.7]	5.0 [3.7]	5.0 [3.7]	5.0 [3.7]	10.0 [7.4]
Weight	kg [lbs]	0.17 [0.37]	0.19 [0.42]	0.17 [0.37]	0.19 [0.42]	0.25 [0.55]
Stroke	mm [in]	15.0 [0.591]	15.0 [0.591]	15.0 [0.591]	15.0 [0.591]	15.0 [0.591]
Advancing force	N [lbf]	83.0 [18.7]	93.0 [20.9]	83.0 [18.7]	93.0 [20.9]	83.0 [18.7]
Spring lock		No	Yes	No	Yes	No
Min. spring force	N [lbf]		7.0 [1.6]		7.0 [1.6]	
Stopper version		No	No	No	No	Yes
Max. permitted finger weight	kg [lbs]	0.12 [0.26]	0.12 [0.26]	0.12 [0.26]	0.12 [0.26]	0.0 [0.00]
Dust protection		No	No	Yes	Yes	No
IP class		40	40	64	64	40
Air consumption per double stroke of a finger	cm ³ [in ³]	4.17 [0.25]	4.17 [0.25]	4.17 [0.25]	4.17 [0.25]	4.17 [0.25]
Nominal pressure	bar [psi]	6.0 [87]	6.0 [87]	6.0 [87]	6.0 [87]	6.0 [87]
Minimum pressure	bar [psi]	2.0 [29]	2.0 [29]	2.0 [29]	2.0 [29]	2.0 [29]
Maximum pressure	bar [psi]	6.0 [87]	6.0 [87]	6.0 [87]	6.0 [87]	6.0 [87]
Min. ambient temperature	°C [°F]	-10.0 [14]	-10.0 [14]	-10.0 [14]	-10.0 [14]	-10.0 [14]
Max. ambient temperature	°C [°F]	90.0 [194]	90.0 [194]	90.0 [194]	90.0 [194]	90.0 [194]

Main views

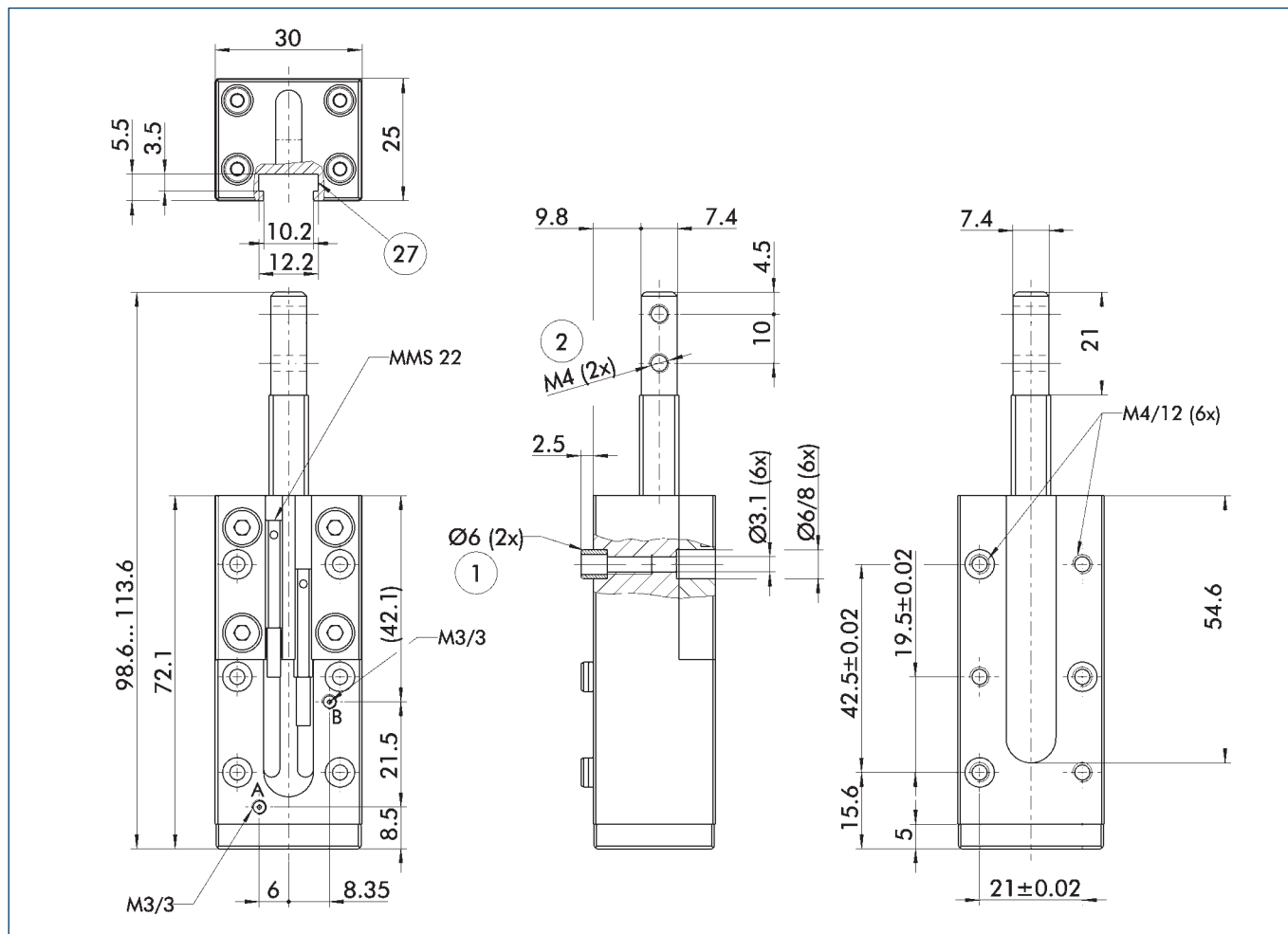

The drawing shows the escapement in the basic version, the dimensions do not include the options described below.

① As an alternative to the spring-loaded positioning lock, the SDV-P pressure maintenance valve can be used (see "Accessories" catalog section).

- A,a Main/direct connection, extend advance linear unit
- B,b Main/direct connection, return retract linear unit
- ① Linear unit connection
- ② Connection of the unit
- ②7 Fastening groove for T-nuts

FS spring lock

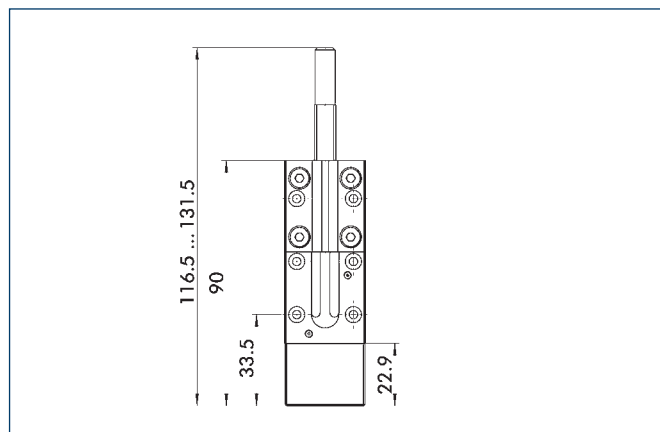

The spring lock ensures that the escapement does not return, thereby releasing the parts, if there is a drop in pressure.

Dust-protection version

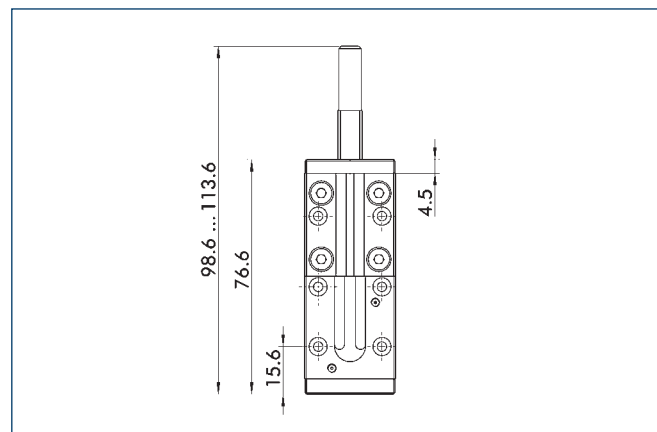

With its additional cover panel, the dust-protection version increases tightness from IP40 to IP64.

Spring lock and dust protection

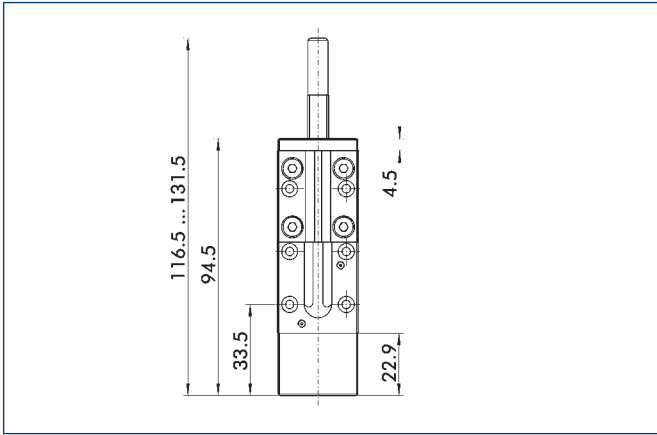

SZ stop cylinder version

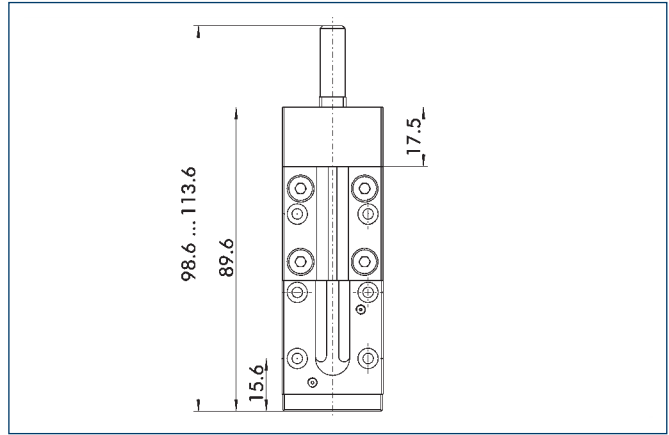

Stopper version for use as a stop cylinder in pallet conveyor systems.
The pallets are stopped directly by the base fingers, no top fingers are mounted.



You can find more detailed information and individual parts of the above-mentioned accessories in the "Accessories" catalog section.

Sensor system

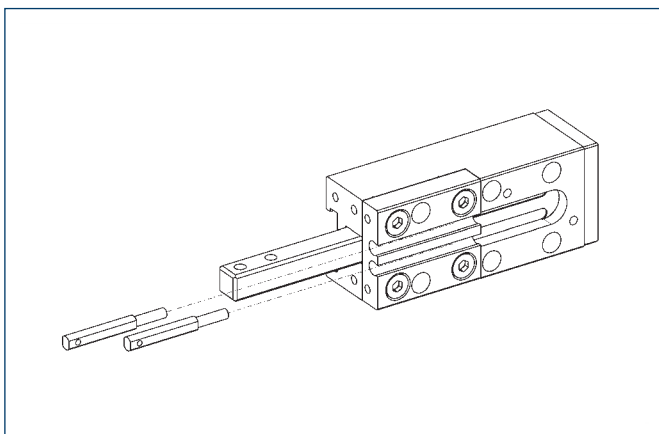

End position monitoring:

Electronic magnetic switches, for mounting in C-slot

Description	ID	Recommended product
MMS 22-S-M5-NPN	0301455	
MMS 22-S-M5-NPN-SA	0301461	
MMS 22-S-M5-PNP	0301454	
MMS 22-S-M5-PNP-SA	0301460	
MMS 22-S-M8-NPN	0301451	
MMS 22-S-M8-NPN-SA	0301457	
MMS 22-S-M8-PNP	0301450	•
MMS 22-S-M8-PNP-SA	0301456	
MMSK 22-S-NPN	0301453	
MMSK 22-S-NPN-SA	0301459	
MMSK 22-S-PNP	0301452	
MMSK 22-S-PNP-SA	0301458	

① Two sensors (NO contacts) are required for each escapement, plus extension cables as an option.

Extension cables for proximity switches/magnetic switches

Description	ID
GK 3-M5-PNP/NPN	0301652
GK 3-M8	0301622
KV 10-M8	0301496
KV 20-M8	0301497
W 3-M5-PNP/NPN	0301650
WK 3-M8	0301594
WK 3-M8 NPN	0301602
WK 5-M8	0301502
WK 5-M8 NPN	9641116

① Please note the minimum permitted bending radii for the sensor cables, which are generally 35 mm.



You can find more detailed information and individual parts of the above-mentioned accessories in the “Accessories” catalog section.

