

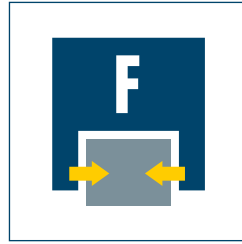

**Sizes**  
1212 .. 2128



**Mass**  
0.54 kg .. 2.33 kg



**Gripping force**  
50 N .. 420 N

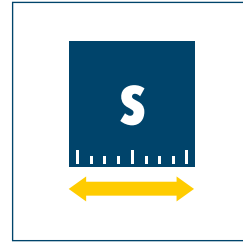

**Stroke per finger**  
2.5 mm .. 8.0 mm



**Torque**  
0.38 Nm .. 1.9 Nm

### Application example

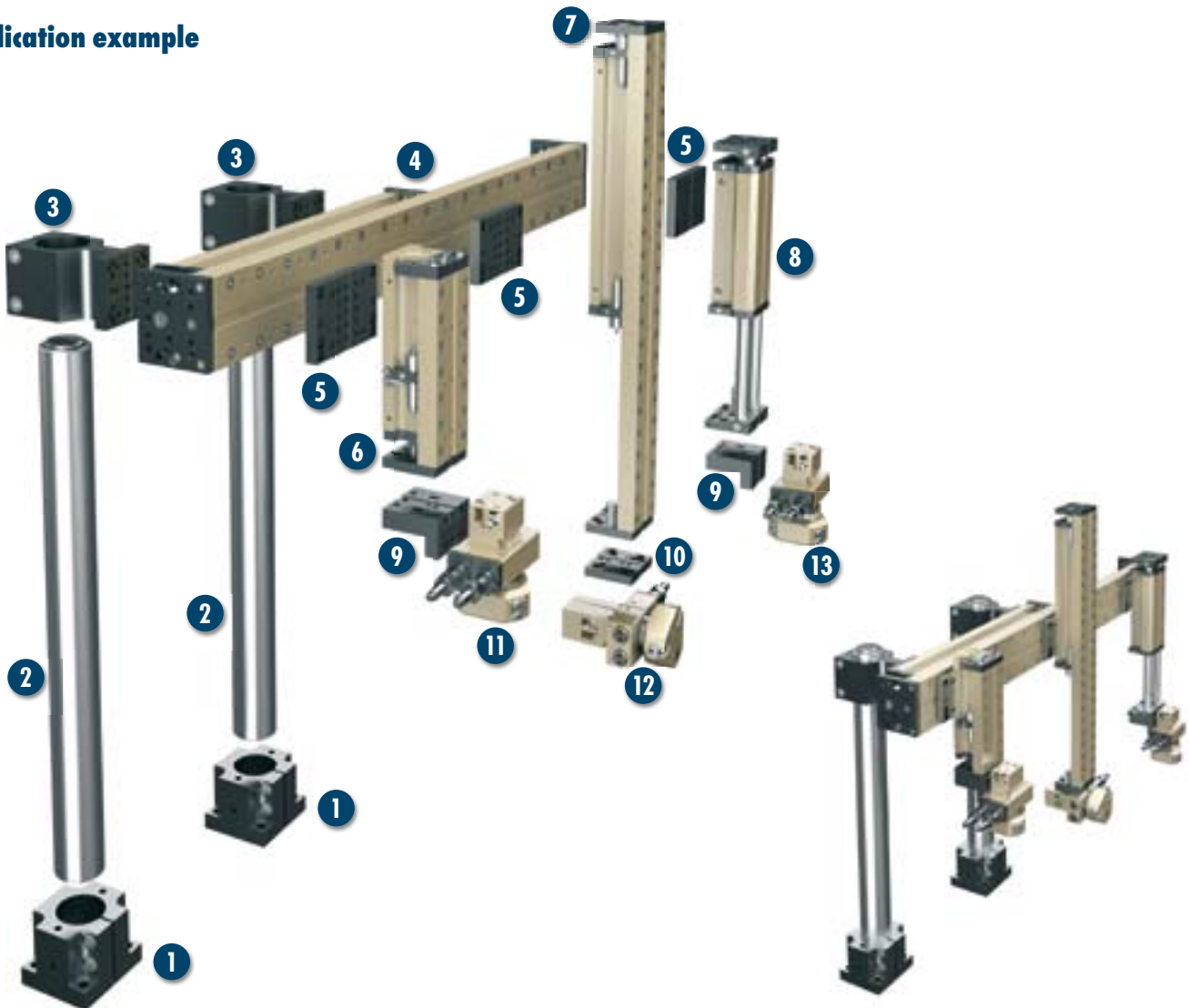

Pneumatic cross gantry with three vertical axes and two rotational axes for workpiece turning of small components

- |   |                                 |    |                                   |
|---|---------------------------------|----|-----------------------------------|
| 1 | Single base support, SOE 055    | 8  | Linear module, KLM 100-H100       |
| 2 | Hollow pillar, SLH 055-0600     | 9  | Adapter plate, APL 123            |
| 3 | Single mounting plate, APEV 085 | 10 | Adapter plate, APL 120            |
| 4 | Linear module, LM 300-H450      | 11 | Gripping rotary module, RC 1520   |
| 5 | Adapter plate, APL 220          | 12 | Gripping rotary module, RC 1520-K |
| 6 | Linear module, CLM 100-H075     | 13 | Gripping rotary module, RC 1520-D |
| 7 | Linear module, LM 100-H200      |    |                                   |

## Rotary module with centric gripper

Rotary gripping combination, consisting of a rotary module and a 3-finger centric gripper

### Area of application

Gripping and rotating combined in one module for small to medium workpieces in low-contamination environments. Also for places where space is limited

### Advantages – your benefits

#### T-slot guidance

For precise gripping at high bearing load capacities

#### Constant clamping force

Over the entire range of stroke

#### Gripping rotary modules without rotating power lines

For maximum reliability

#### Choice of I.D. or O.D. gripping

For maximum flexibility in applications

#### Integration of a gripping force retaining device is optional

For firm grip even in the event of power failure

#### Continuous angle of rotation adjustment

Over the entire range of rotation

#### Double piston design in the swivel unit

For elimination of backlash at the end positions and high repeat accuracy

#### Integrated shock absorbers with adjustable absorption characteristic

For optimal dampening

#### “Continuously adjustable intermediate position” option

Can be done using an intermediate stop which can be integrated

#### End-position monitoring

Up to four monitoring sets possible

#### Standardized mounting bores

For numerous combinations with other GEMOTEC system elements

### General information about the series

#### Working principle

Combination of rack/pinion with piston actuation

#### Housing material

Aluminum alloy, hard-anodized

#### Base jaw material

Steel

#### Actuation

Pneumatic, via filtered compressed air (10 µm): dry, lubricated, or non-lubricated  
Pressurizing medium: requirements for compressed air quality class according to DIN ISO 8573-1: Quality class 4

#### Scope of delivery

Completely ready for operation  
without bracket for proximity switch and without proximity switch

#### Warranty

24 months

#### Gripping force retaining device

Possible with variants with mechanical gripping force safety devices or pressure maintenance valves

#### Modular design

Gripping rotary modules are designed to be modular and consist of flat swivel units, RM 12 - 21, and GMC grippers

For production reasons, the colors may vary from those shown in the catalog.



## Cross-section of function

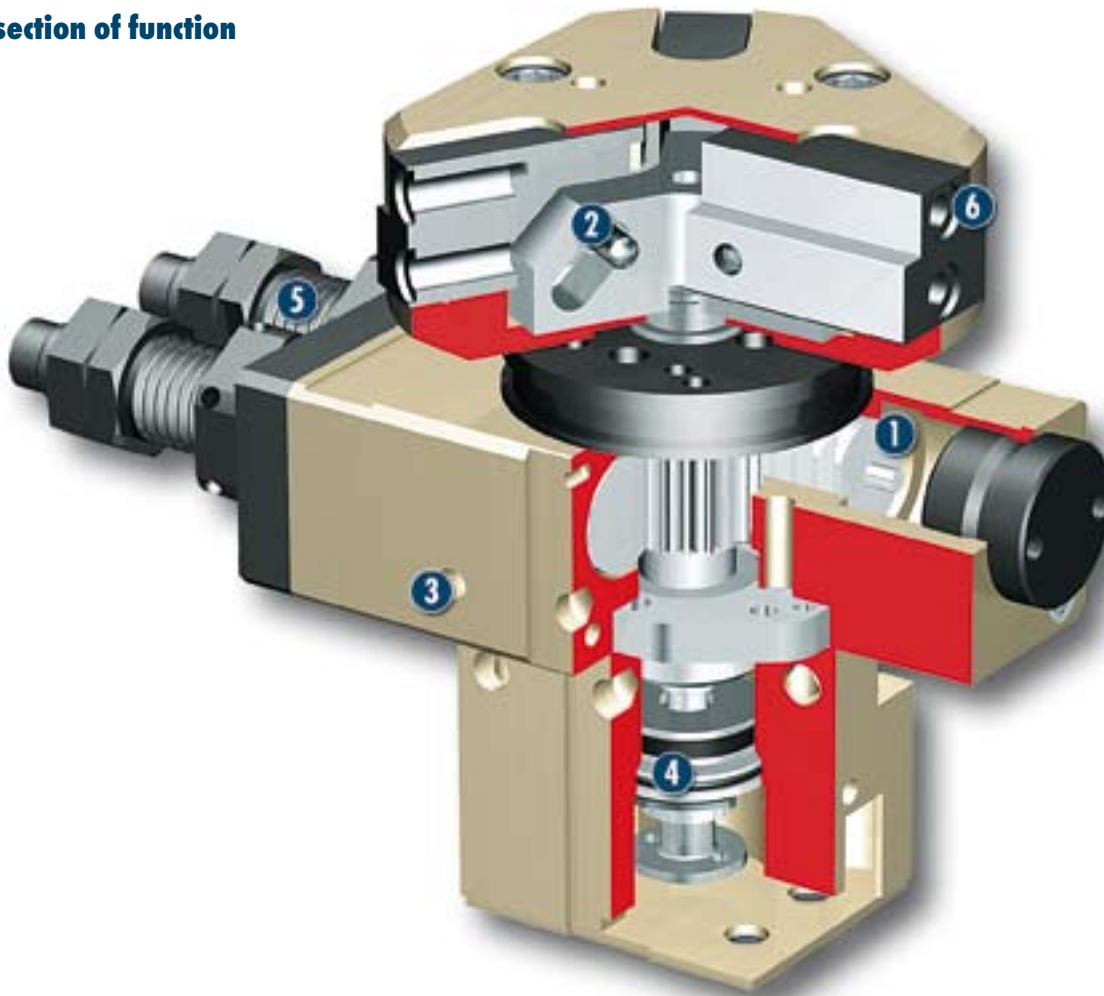

- |  |  |  |
|--|--|--|
| <p><b>1 Drive, turning</b><br/>Pneumatic, rack and pinion design</p>       | <p><b>3 Modular design hole pattern</b><br/>Completely integrated in the module system</p> | <p><b>5 Rotating angle adjustment</b><br/>For a flexible end position, with hydraulic shock absorber</p> |
| <p><b>2 Kinematics</b><br/>Inside, power transmission via line contact</p> | <p><b>4 Drive, gripping</b><br/>Double pressurized piston-actuated system</p>              | <p><b>6 Base jaws</b><br/>For adaptation of the workpiece-specific gripper fingers</p>                   |

## Description of function

The rotary movement is done by the two pneumatic piston racks when pressure is applied to their end faces, causing them to move in a straight line in their bore holes and turn the pinion by way of the teeth machined on the side of the racks. For the gripping movement, the piston is moved up or down using compressed air. The wedge links the piston movement in a synchronized opening and closing together with the guidance of the base jaws.

## Options and special information

**Rotation adapter version**

The gripping head can be continuously adjusted and indexed in relation to the drive.

No power lines are rotated with the unit.

This module can be combined as standard with many elements from the modular system. You can find more information in the "Accessories" chapter.

## Accessories

Accessories from SCHUNK – the ideal components for the best functionality, reliability, and controlled production for all automation modules.

Fittings



Centering strips



Adapter plates

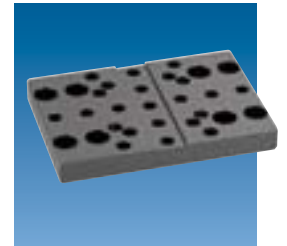

Inductive proximity switch, NI



Sensor cable



Pillar assembly systems



Pressure maintenance valve



① Please see the side views at the end of the respective size for information concerning specific sizes, accessories availability for that size, designation, and ID numbers. You can find more information about our accessories program in the 'Accessories' part of the catalog.

## General information about the series

### Gripping force

This is the arithmetic sum of the gripping forces applied to each claw jaw, measured at a distance of 10 mm from the upper edge of the gripper.

### Pinion position

The position of the pinion is always shown in the left end position. The pinion rotates from here to the right in the clockwise direction. The arrow makes the direction of rotation clear.

### Screw connection diagram at the pinion

Please note that when the rotating angle is to be set for less than 90°, the left stop will generally be completely turned in. The left end position therefore has a

screw connection diagram which has been rotated by 90° in the clockwise direction in relation to the drawing, which is shown at a 180° angle of rotation.

### Finger length

The finger length is measured from the upper edge of the gripper housing in the direction of the main axis.

### Layout or sizing

For layout or sizing of rotary modules, we recommend using our TOOLBOX sizing software, which can be obtained at [www.schunk.com](http://www.schunk.com). Sizing the selected unit is absolutely necessary, since otherwise overloading can result.



### Gripping force, I.D. gripping

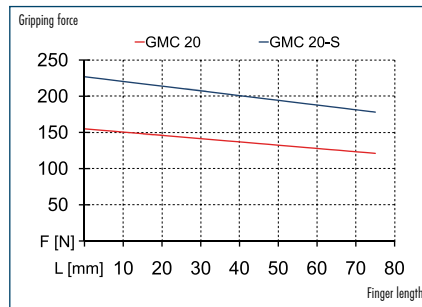

### Gripping force, O.D. gripping

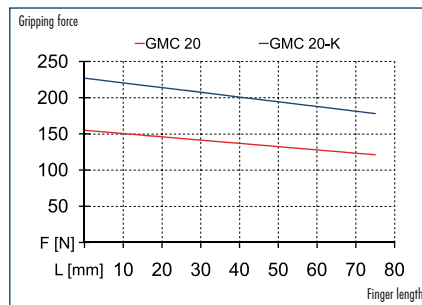

### Moment load

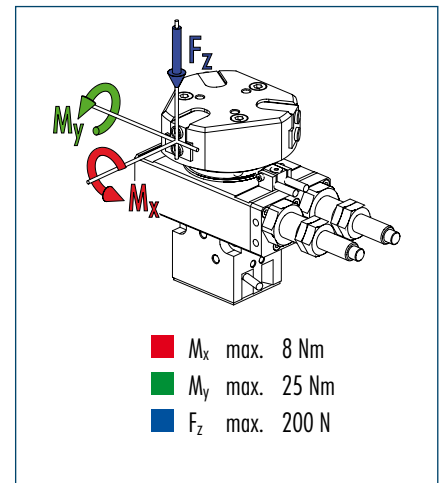

① Moments and forces apply per base jaw and may occur at the same time.  $M_y$  may occur additionally to the moment produced by the gripping force itself. For heavy structures or superstructures with high mass moment of inertia, limiting is necessary to ensure that rotary movement takes place without striking or bouncing.

## Technical data

Designation		RC 1520	RC 1520-K	RC 1520-S
	ID	0313280	0313282	0313281
Stroke per jaw	[mm]	5	5	5
Closing grip force	[N]	150	220	
Opening grip force	[N]	150		220
Min. grip force applied by spring	[N]		70	70
Torque	[Nm]	0.76	0.76	0.76
Angle of rotation	[°]	190	190	190
End position adjustability	[°]	Continuous	Continuous	Continuous
Recommended workpiece weight	[kg]	0.75	0.75	0.75
Fluid consumption for gripping per cycle	[cm <sup>3</sup> ]	2.86	2.86	2.86
Fluid consumption for swiveling per cycle	[cm <sup>3</sup> ]	9.6	9.6	9.6
Mass	[kg]	1.08	1.16	1.16
Nominal operating pressure	[bar]	6	6	6
Minimum pressure for gripping	[bar]	3	5	5
Maximum pressure for gripping	[bar]	8	8	8
Minimum pressure for swiveling	[bar]	3	3	3
Maximum pressure for swiveling	[bar]	8	8	8
Closing time for gripping	[s]	0.03	0.025	0.04
Opening time for gripping	[s]	0.03	0.04	0.025
Max. permissible finger length	[mm]	75	75	75
IP rating		40	40	40
Min. ambient temperature	[°C]	5	5	5
Max. ambient temperature	[°C]	60	60	60
Repeat accuracy for gripping	[mm]	± 0.02	± 0.02	± 0.02
Repeat accuracy for swiveling	[°]	± 0.05	± 0.05	± 0.05

### OPTIONS and their characteristics

Designation		RC 1520-D	RC 1520-Z	RC 1520-X
	ID	0313283	0313285	0313284
Mass	[kg]	1.14	1.22	1.22

### Main views

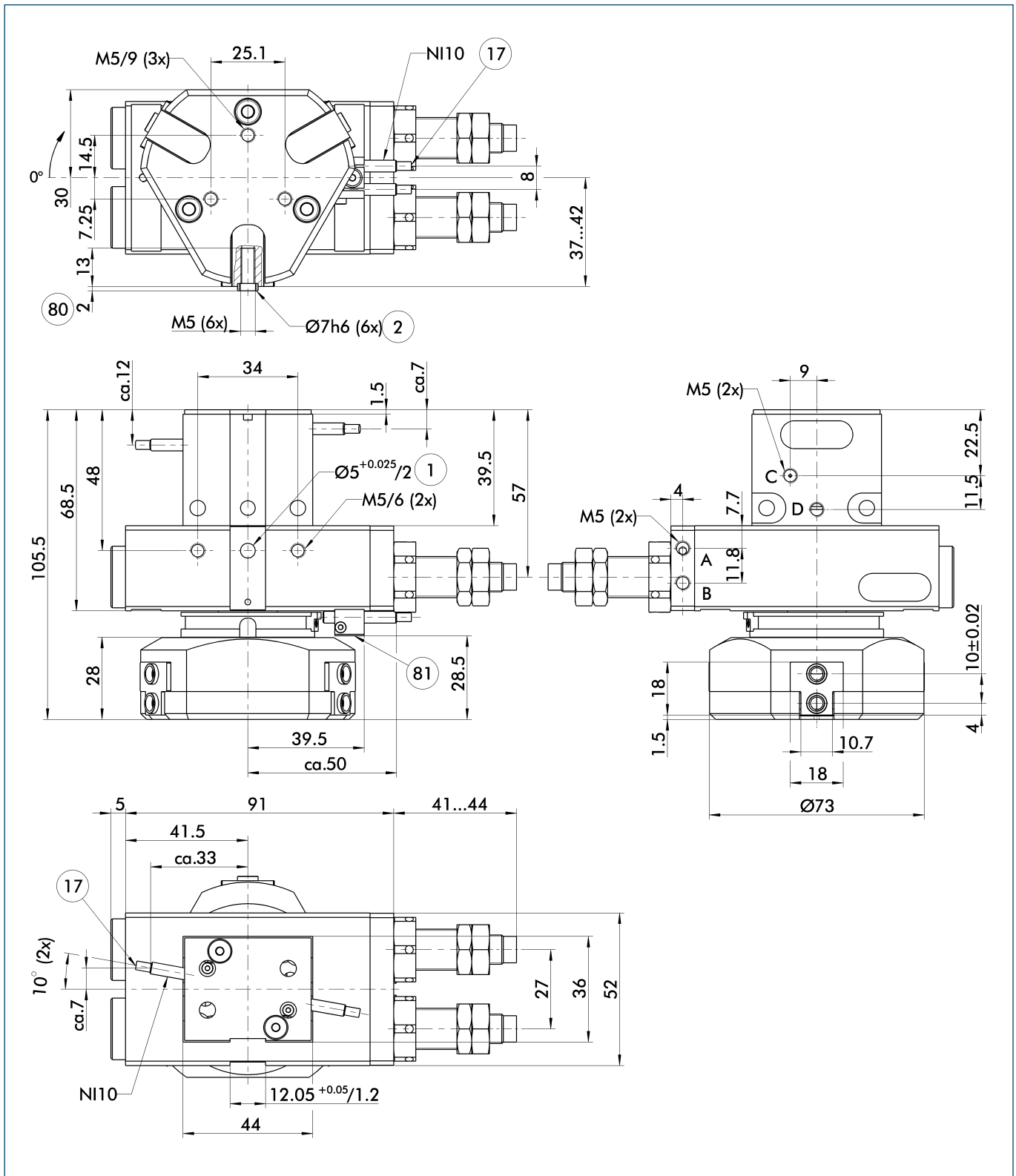

- A,a Main and direct connections, swivel unit, rotating to the right
- B,b Main and direct connections, swivel unit, rotating to the left
- C,c Main and direct connections, gripper open
- D,d Main and direct connections, gripper close
- ① Connections, gripping rotary module
- ② Finger connection
- ⑰ Cable outlet
- ⊘ Depth of the centering sleeve in the counter piece
- ⊘ Not included in the scope of delivery

### Gripping force safety device, K/S

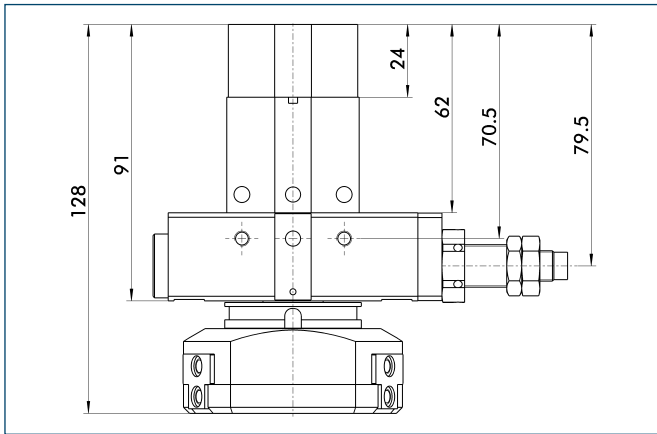

The mechanical gripping force safety device ensures that a minimum clamping force will be applied even if there is a drop in pressure. This acts as closing grip force for the K variant and as opening grip force for the S variant. The gripping force safety device can be installed without other components from the K variant into the S variant and vice versa. Besides this, the gripping force safety device can be used to increase gripping force or for single actuated gripping.

### Rotation adapter D

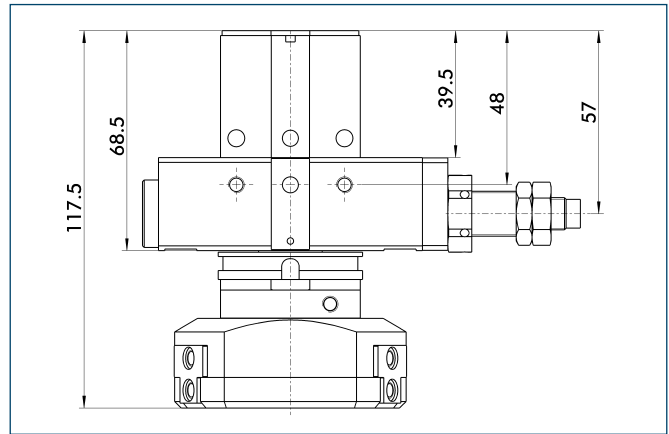

The two-part rotation adapter enables the gripping head to be continuously rotated in order to flexibly adjust the position of the gripper fingers on the workpiece. Only the clamping screw has to be released to do this. After the adjustment has been made, a hole can be drilled out to place a cylindrical pin or a fixing thread for clamping.

### Gripping force safety device + rotation adapter Z/X

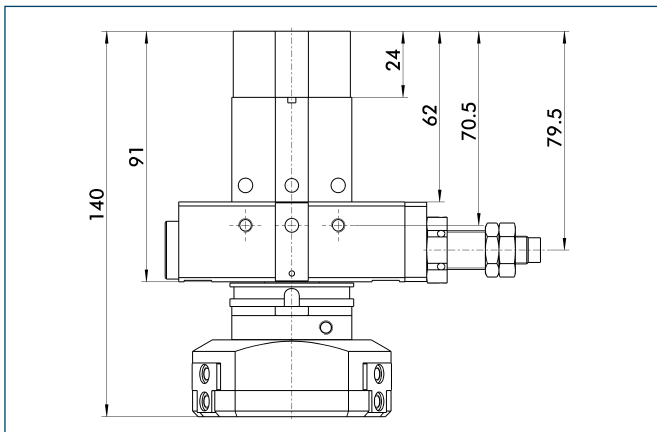

This variant combines the functions of the gripping force safety device with that of the rotation adapter. The gripping force safety device acts as closing grip force for the Z variant and as opening grip force for the X variant.

### Sensor systems

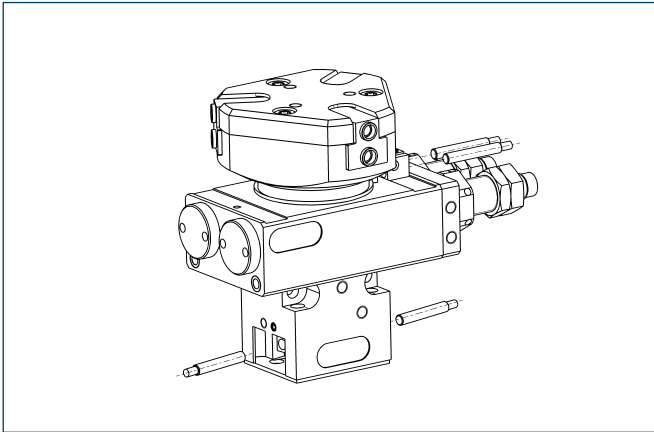

**End-position monitoring:**  
Inductive proximity switch, can be directly mounted

#### Rotating motion

Designation	ID	Scope of delivery	Recommended product
RMNS 12-X	0313041	1 x bracket, 2 x sensors, 2 x operating targets	
RMNS 12-G	0313042	1 x bracket, 2 x sensors, 2 x operating targets, 2 x straight cable extensions	•
RMNS 12-W	0313043	1 x bracket, 2 x sensors, 2 x operating targets, 2 x angled cable extensions	

#### Gripping movement

Designation	ID	Scope of delivery	Recommended product
GMNS 16-X	0313333	Bracket, sensor	
GMNS 16-G	0313334	Bracket, sensor, straight cable extension	•
GMNS 16-W	0313335	Bracket, sensor, angled cable extension	

ⓘ Two sensors are needed for each gripper

 You can find further information and components for the accessories mentioned here in the "Accessories" part of the catalog.