

Gripping rotary modules

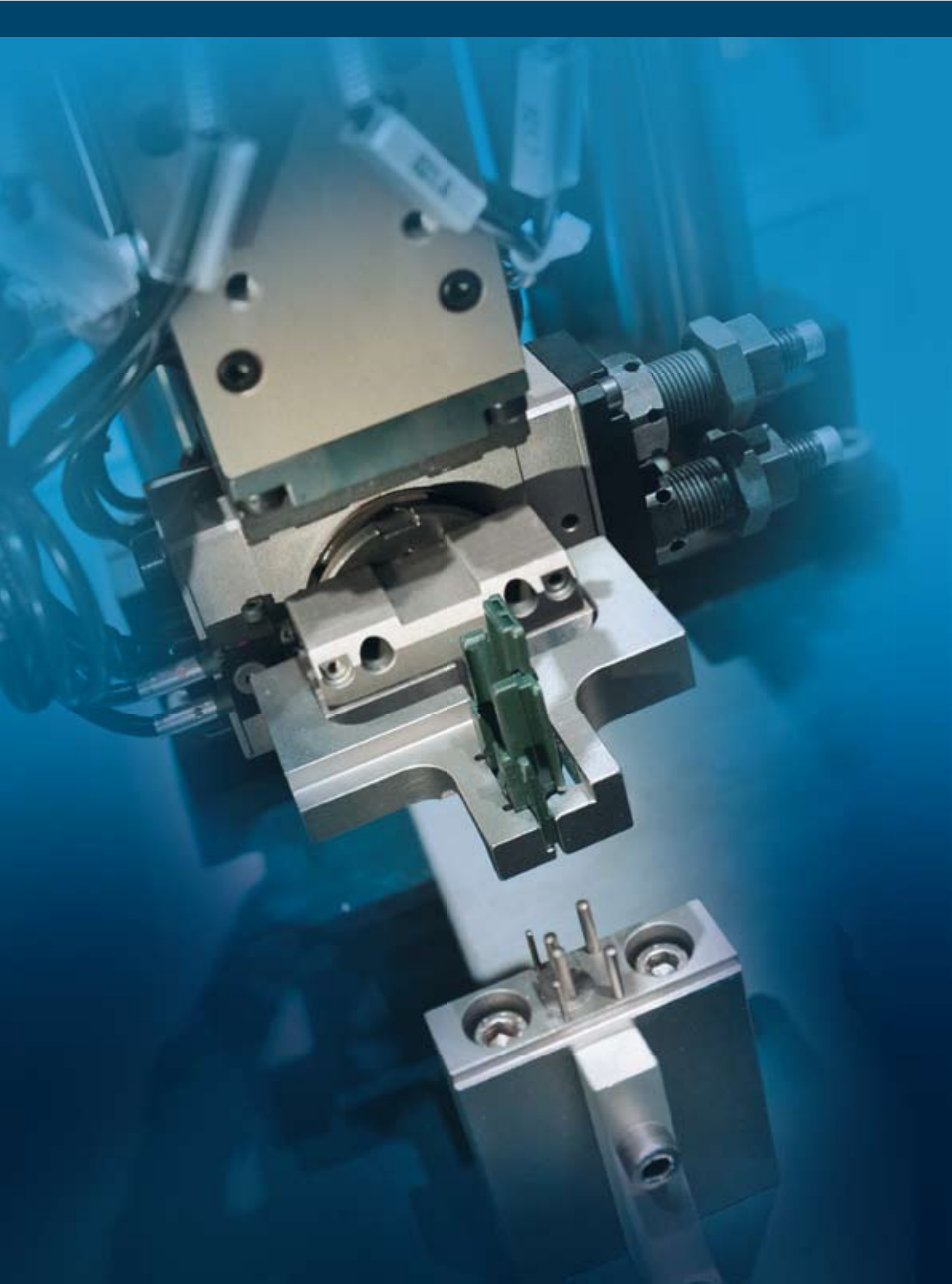

GRIPPING ROTARY MODULES

Series	Size	Page
Gripping rotary modules		
RP		314
RP	1212	318
RP	1216	322
RP	1520	326
RP	2120	330
RP	2128	334
RC		338
RC	1212	342
RC	1216	346
RC	1520	350
RC	2120	354
RC	2128	358
RW		362
RW	1212	366
RW	1216	370
RW	1520	374
RW	2120	378
RW	2128	382

SCHUNK offers you the most extensive program of gripping modules and gripping rotary modules.

From pneumatically or electrically driven grippers to small-component, universal, and long-stroke grippers and industry-specific gripping solutions.

Please consult our main catalog for further information about SCHUNK gripping modules.

Here is an extract from our range of products about gripping rotary modules.



Gripping rotary modules



Swivel actuator with integrated 2-finger parallel gripper



Swivel actuator with integrated 3-finger centric gripper



Sizes
1212 .. 2128



Mass
0.50 kg .. 2.02 kg

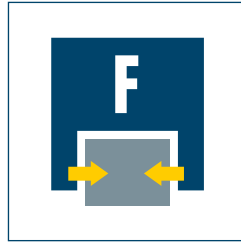

Gripping force
50 N .. 420 N



Stroke per finger
2.5 mm .. 8.0 mm



Torque
0.38 Nm .. 1.9 Nm

Application example

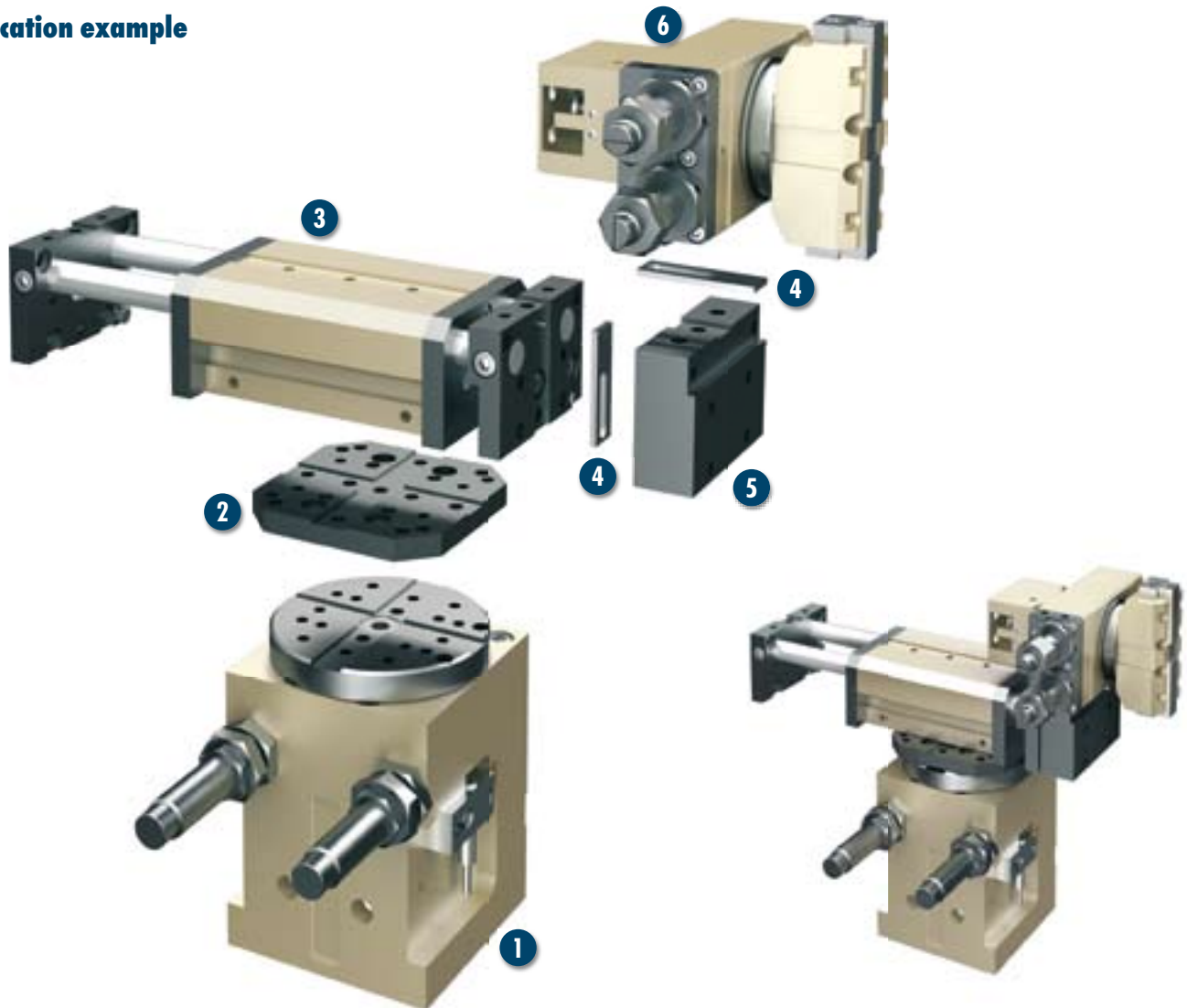

Pneumatic converting/turning-over unit for small components

- 1 Rotary module, RM 200-W180-2
- 2 Adapter plate, APL 320
- 3 Linear module, KLM 050-H050

- 4 Centering strip, LMZL 50
- 5 Adapter plate, APL 103
- 6 Gripping rotary module, RP 1520

Rotary module with parallel gripper

Rotary gripping combination, consisting of a rotary module and a 2-finger parallel gripper

Area of application

Gripping and rotating combined in one module for small to medium workpieces in low-contamination environments.
Also for places where space is limited

Advantages – your benefits

Constant clamping force

Over the entire range of stroke

Gripping rotary modules without rotating power lines

For maximum reliability

Choice of I.D. or O.D. gripping

For maximum flexibility in applications

Integration of a gripping force retaining device is optional

For firm grip even in the event of power failure

Continuous angle of rotation adjustment

Over the entire range of rotation

Double piston design in the swivel unit

For elimination of backlash at the end positions and high repeat accuracy

Integrated shock absorbers with adjustable absorption characteristic

For optimal dampening

“Continuously adjustable intermediate position” option

Can be done using an intermediate stop which can be integrated

End-position monitoring

Up to four monitoring sets possible

Standardized mounting bores

For numerous combinations with other GEMOTEC system elements



General information about the series

Working principle

Combination of rack/pinion with piston actuation

Housing material

Aluminum alloy, hard-anodized

Base jaw material

Steel

Actuation

Pneumatic, via filtered compressed air (10 µm): dry, lubricated, or non-lubricated
Pressurizing medium: requirements for compressed air quality class according to DIN ISO 8573-1: Quality class 4

Scope of delivery

Completely ready for operation
without bracket for proximity switch and without proximity switch

Warranty

24 months

Gripping force retaining device

Possible with variants with mechanical gripping force safety devices or pressure maintenance valves

Modular design

Gripping rotary modules are designed to be modular and consist of flat swivel units, RM 12 - 21, and GMP grippers

For production reasons, the colors may vary from those shown in the catalog.

Cross-section of function

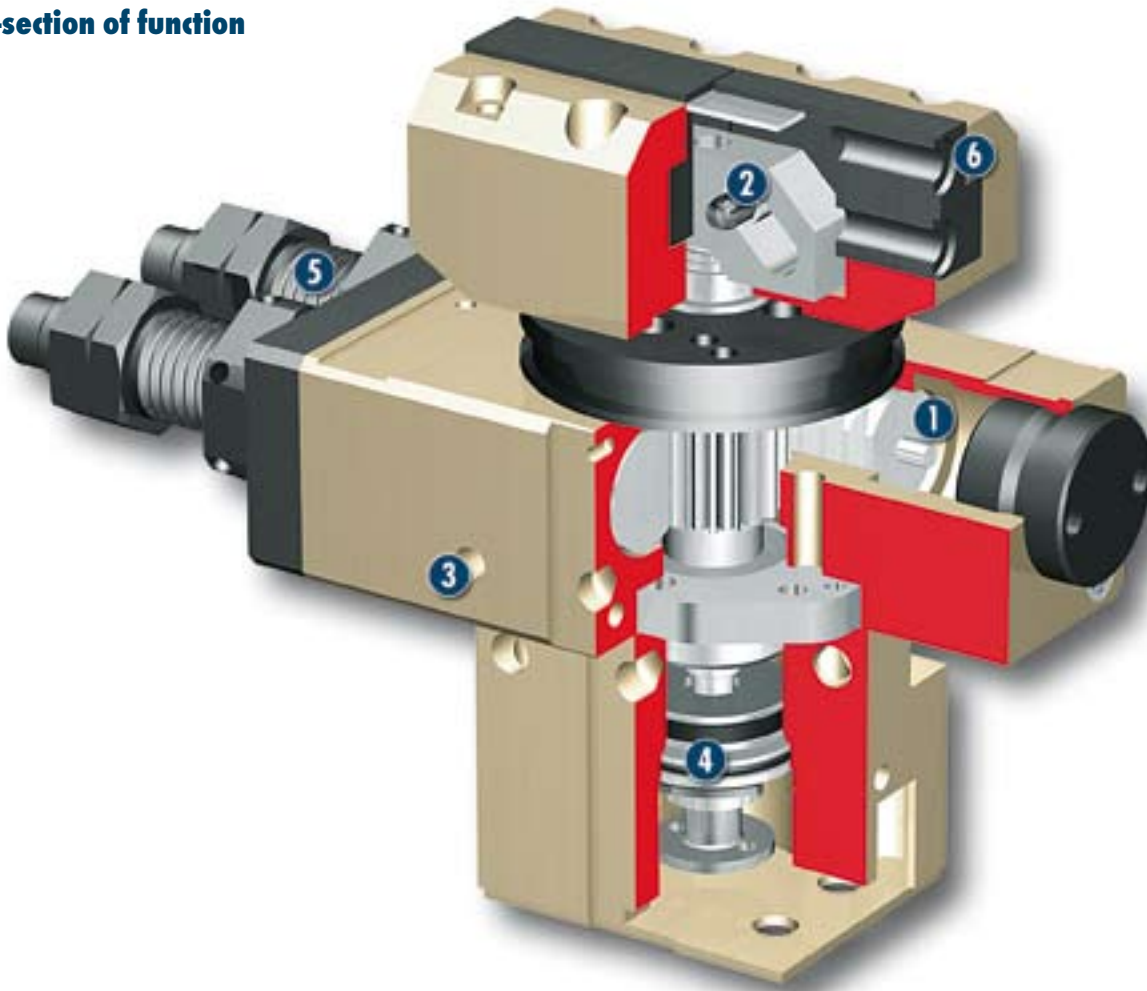

- 1 Drive, turning**
Pneumatic, rack and pinion design
- 2 Kinematics**
Inside, power transmission via line contact
- 3 Modular design hole pattern**
Completely integrated in the module system
- 4 Drive, gripping**
Double pressurized piston-actuated system
- 5 Rotating angle adjustment**
For a flexible end position, with hydraulic shock absorber
- 6 Base jaws**
For adaptation of the workpiece-specific gripper fingers

Description of function

The rotary movement is done by the two pneumatic piston racks when pressure is applied to their end faces, causing them to move in a straight line in their bore holes and turn the pinion by way of the teeth machined on the side of the racks. For the gripping movement, the piston is moved up or down using compressed air. The wedge links the piston movement in a synchronized opening and closing together with the guidance of the base jaws.

Options and special information

Rotation adapter version

The gripping head can be continuously adjusted and indexed in relation to the drive.

No power lines are rotated with the unit.

This module can be combined as standard with many elements from the modular system. You can find more information in the "Accessories" chapter.

Accessories

Accessories from SCHUNK – the ideal components for the best functionality, reliability, and controlled production for all automation modules.

Fittings



Centering strips



Adapter plates

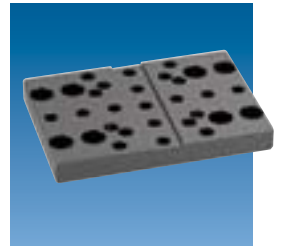

Inductive proximity switch, NI



Sensor cable



Pillar assembly systems



Pressure maintenance valve



ⓘ Please see the side views at the end of the respective size for information concerning specific sizes, accessories availability for that size, designation, and ID numbers. You can find more information about our accessories program in the 'Accessories' part of the catalog.

General information about the series

Gripping force

This is the arithmetic sum of the gripping forces applied to each claw jaw, measured at a distance of 10 mm from the upper edge of the gripper.

Pinion position

The position of the pinion is always shown in the left end position. The pinion rotates from here to the right in the clockwise direction. The arrow makes the direction of rotation clear.

Screw connection diagram at the pinion

Please note that when the rotating angle is to be set for less than 90°, the left stop will generally be completely turned in. The left end position therefore has a

screw connection diagram which has been rotated by 90° in the clockwise direction in relation to the drawing, which is shown at a 180° angle of rotation.

Finger length

The finger length is measured from the upper edge of the gripper housing in the direction of the main axis.

Layout or sizing

For layout or sizing of rotary modules, we recommend using our TOOLBOX sizing software, which can be obtained at www.schunk.com. Sizing the selected unit is absolutely necessary, since otherwise overloading can result.



Gripping force, I.D. gripping

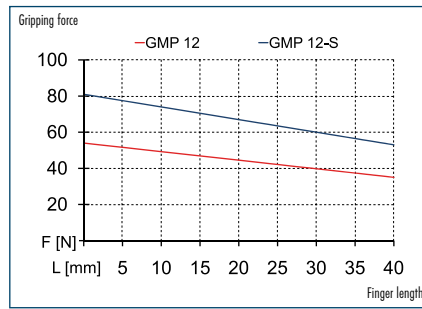

Gripping force, O.D. gripping

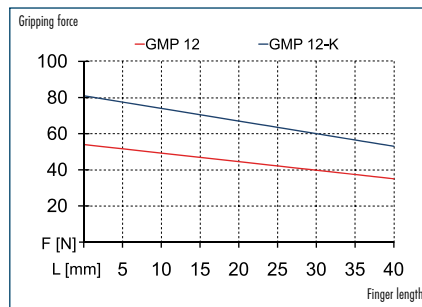

Moment load

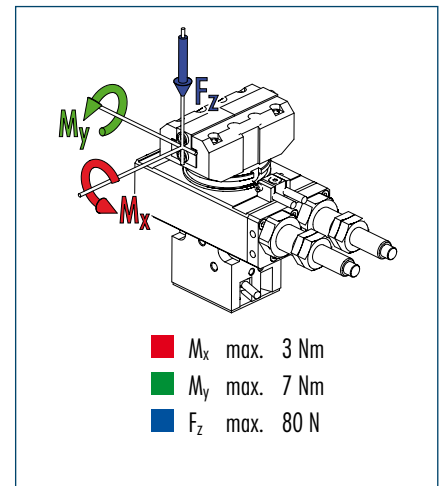

① Moments and forces apply per base jaw and may occur at the same time. M_y may occur additionally to the moment produced by the gripping force itself. For heavy structures or superstructures with high mass moment of inertia, limiting is necessary to ensure that rotary movement takes place without striking or bouncing.

Technical data

Designation		RP 1212	RP 1212-K	RP 1212-S
	ID	0313220	0313222	0313221
Stroke per jaw	[mm]	2.5	2.5	2.5
Closing grip force	[N]	50	75	
Opening grip force	[N]	50		75
Min. grip force applied by spring	[N]		25	25
Torque	[Nm]	0.38	0.38	0.38
Angle of rotation	[°]	190	190	190
End position adjustability	[°]	Continuous	Continuous	Continuous
Recommended workpiece weight	[kg]	0.25	0.25	0.25
Fluid consumption for gripping per cycle	[cm ³]	0.87	0.87	0.87
Fluid consumption for swiveling per cycle	[cm ³]	4.8	4.8	4.8
Mass	[kg]	0.5	0.52	0.52
Nominal operating pressure	[bar]	6	6	6
Minimum pressure for gripping	[bar]	3	5	5
Maximum pressure for gripping	[bar]	8	8	8
Minimum pressure for swiveling	[bar]	3	3	3
Maximum pressure for swiveling	[bar]	8	8	8
Closing time for gripping	[s]	0.02	0.015	0.025
Opening time for gripping	[s]	0.02	0.025	0.015
Max. permissible finger length	[mm]	40	40	40
IP rating		40	40	40
Min. ambient temperature	[°C]	5	5	5
Max. ambient temperature	[°C]	60	60	60
Repeat accuracy for gripping	[mm]	± 0.02	± 0.02	± 0.02
Repeat accuracy for swiveling	[°]	± 0.049	± 0.049	± 0.049

OPTIONS and their characteristics

Designation		RP 1212-D	RP 1212-Z	RP 1212-X
	ID	0313223	0313225	0313224
Mass	[kg]	0.52	0.54	0.54

Main views

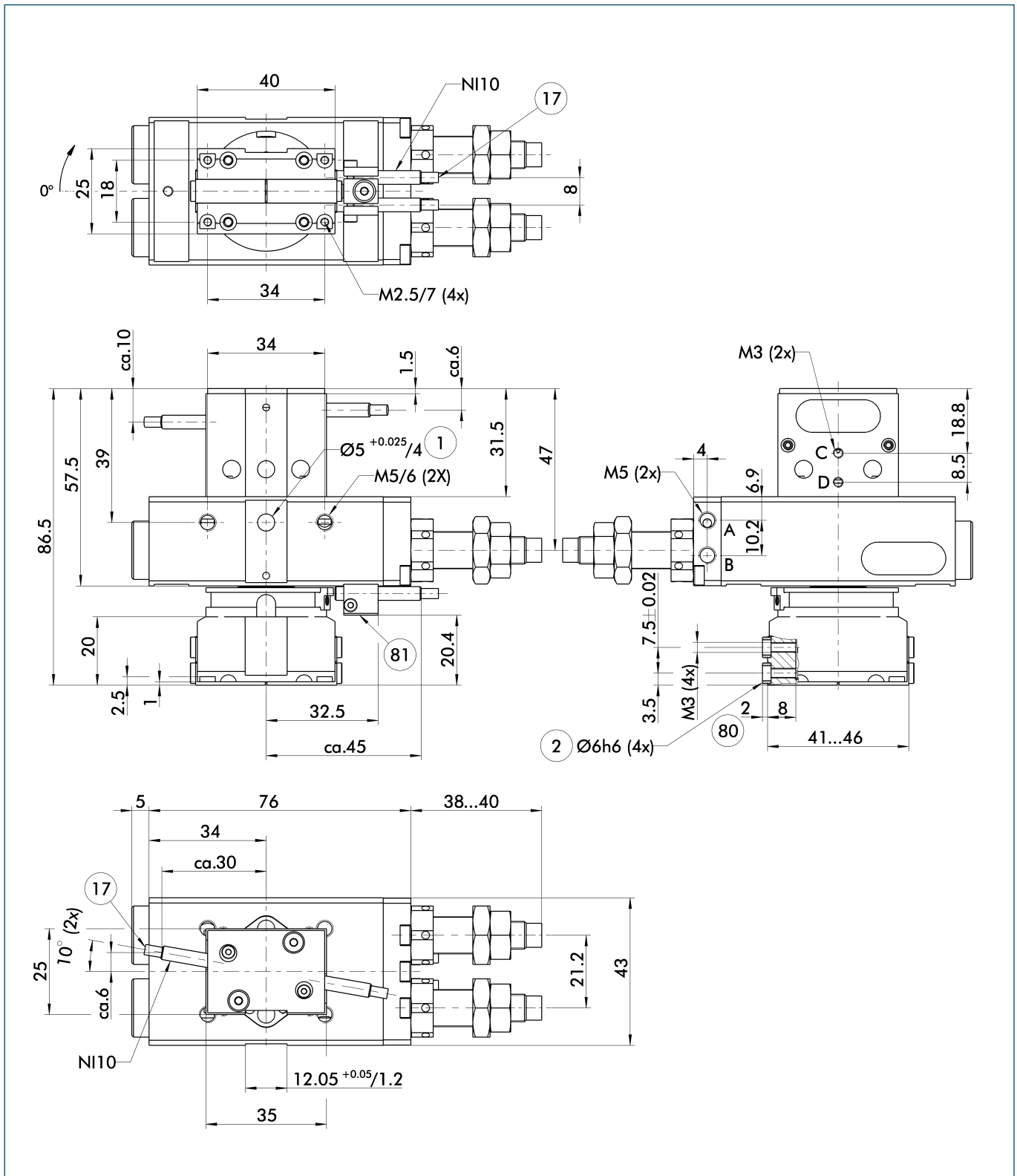

- A,a Main and direct connections, swivel unit, rotating to the right
- B,b Main and direct connections, swivel unit, rotating to the left
- C,c Main and direct connections, gripper open
- D,d Main and direct connections, gripper close
- ① Connections, gripping rotary module
- ② Finger connection
- ①⑦ Cable outlet
- ⑧⑩ Depth of the centering sleeve in the counter piece
- ⑧⑩ Not included in the scope of delivery

Gripping force safety device, K/S

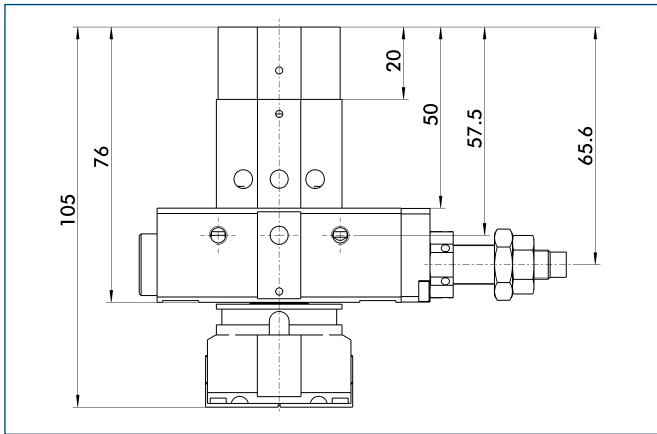

The mechanical gripping force safety device ensures that a minimum clamping force will be applied even if there is a drop in pressure. This acts as closing grip force for the K variant and as opening grip force for the S variant. The gripping force safety device can be installed without other components from the K variant into the S variant and vice versa. Besides this, the gripping force safety device can be used to increase gripping force or for single actuated gripping.

Rotation adapter D

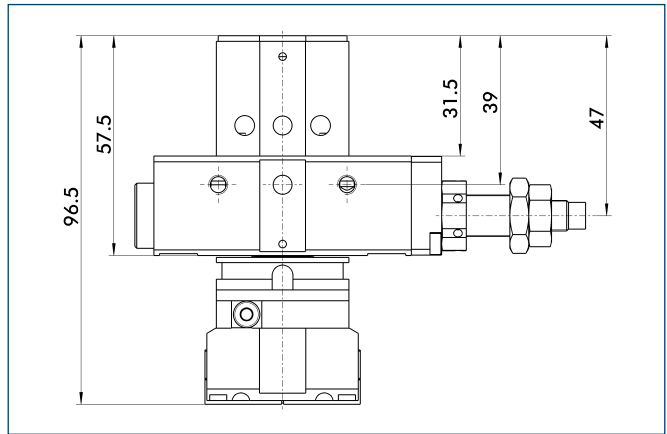

The two-part rotation adapter enables the gripping head to be continuously rotated in order to flexibly adjust the position of the gripper fingers on the workpiece. Only the clamping screw has to be released to do this. After the adjustment has been made, a hole can be drilled out to place a cylindrical pin or a fixing thread for clamping.

Gripping force safety device + rotation adapter Z/X

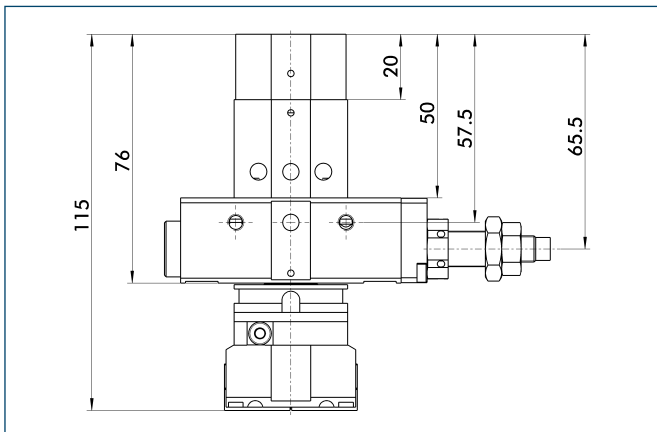

This variant combines the functions of the gripping force safety device with that of the rotation adapter. The gripping force safety device acts as closing grip force for the Z variant and as opening grip force for the X variant.

Sensor systems

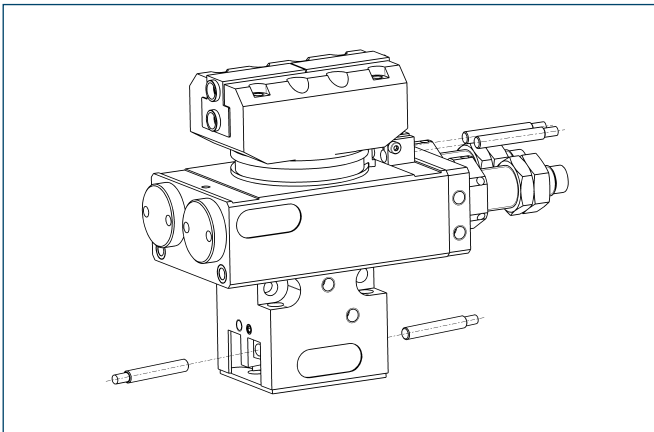

End-position monitoring:
Inductive proximity switch, can be directly mounted

Rotating motion

Designation	ID	Scope of delivery	Recommended product
RMNS 12-X	0313041	1 x bracket, 2 x sensors, 2 x operating targets	
RMNS 12-G	0313042	1 x bracket, 2 x sensors, 2 x operating targets, 2 x straight cable extensions	•
RMNS 12-W	0313043	1 x bracket, 2 x sensors, 2 x operating targets, 2 x angled cable extensions	

Gripping movement

Designation	ID	Scope of delivery	Recommended product
GMNS 12-X	0313330	Bracket, sensor	
GMNS 12-G	0313331	Bracket, sensor, straight cable extension	•
GMNS 12-W	0313332	Bracket, sensor, angled cable extension	

ⓘ Two sensors are needed for each gripper

 You can find further information and components for the accessories mentioned here in the "Accessories" part of the catalog.



Gripping force, I.D. gripping

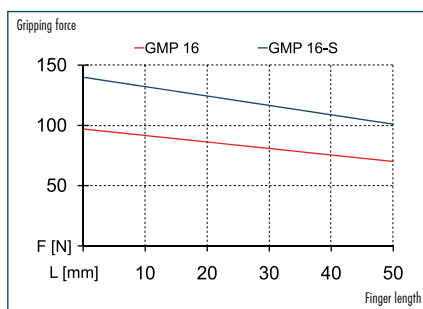

Gripping force, O.D. gripping

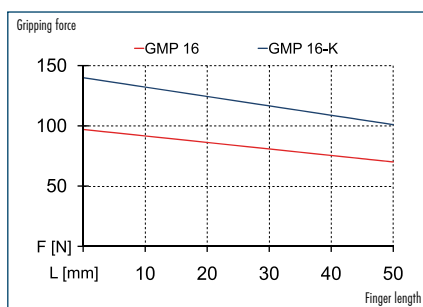

Moment load

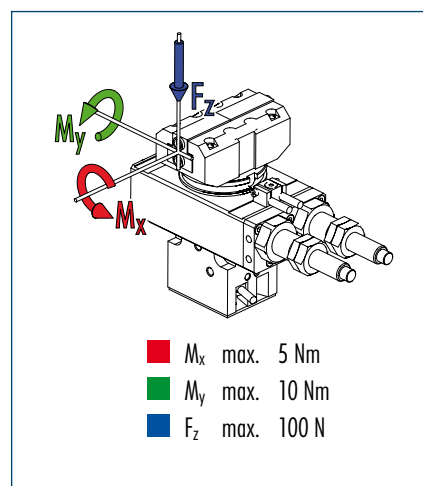

① Moments and forces apply per base jaw and may occur at the same time. M_y may occur additionally to the moment produced by the gripping force itself. For heavy structures or superstructures with high mass moment of inertia, limiting is necessary to ensure that rotary movement takes place without striking or bouncing.

Technical data

Designation		RP 1216	RP 1216-K	RP 1216-S
	ID	0313242	0313244	0313243
Stroke per jaw	[mm]	3	3	3
Closing grip force	[N]	90	130	
Opening grip force	[N]	90		130
Min. grip force applied by spring	[N]		40	40
Torque	[Nm]	0.38	0.38	0.38
Angle of rotation	[°]	190	190	190
End position adjustability	[°]	Continuous	Continuous	Continuous
Recommended workpiece weight	[kg]	0.45	0.45	0.45
Fluid consumption for gripping per cycle	[cm ³]	1.1	1.1	1.1
Fluid consumption for swiveling per cycle	[cm ³]	4.8	4.8	4.8
Mass	[kg]	0.56	0.62	0.62
Nominal operating pressure	[bar]	6	6	6
Minimum pressure for gripping	[bar]	3	5	5
Maximum pressure for gripping	[bar]	8	8	8
Minimum pressure for swiveling	[bar]	3	3	3
Maximum pressure for swiveling	[bar]	8	8	8
Closing time for gripping	[s]	0.02	0.015	0.025
Opening time for gripping	[s]	0.02	0.025	0.015
Max. permissible finger length	[mm]	50	50	50
IP rating		40	40	40
Min. ambient temperature	[°C]	5	5	5
Max. ambient temperature	[°C]	60	60	60
Repeat accuracy for gripping	[mm]	± 0.02	± 0.02	± 0.02
Repeat accuracy for swiveling	[°]	± 0.049	± 0.049	± 0.049

OPTIONS and their characteristics

Designation		RP 1216-D	RP 1216-Z	RP 1216-X
	ID	0313245	0313247	0313246
Mass	[kg]	0.6	0.64	0.64

Main views

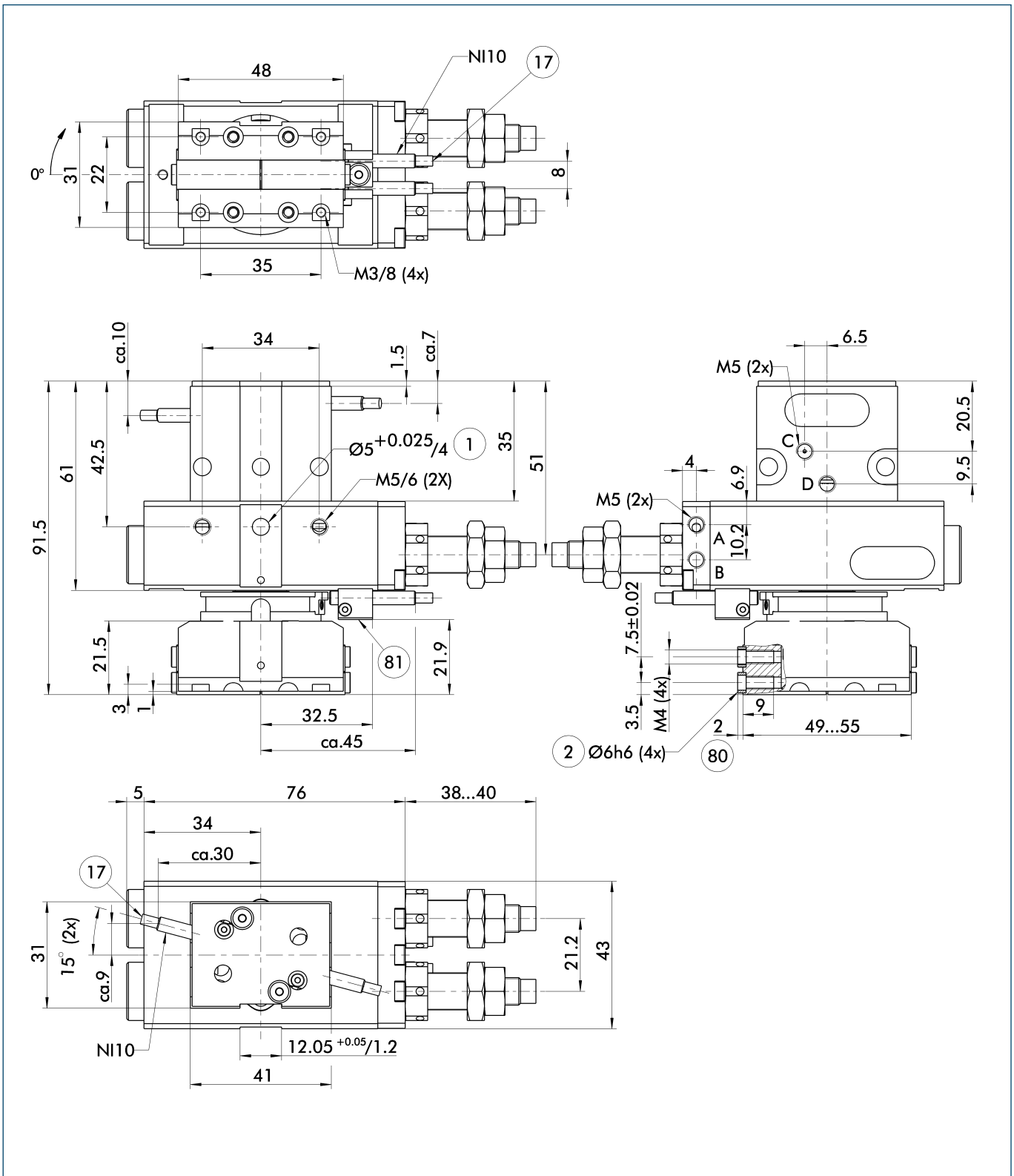

- A,a Main and direct connections, swivel unit, rotating to the right
- B,b Main and direct connections, swivel unit, rotating to the left
- C,c Main and direct connections, gripper open
- D,d Main and direct connections, gripper close
- ① Connections, gripping rotary module
- ② Finger connection
- ⑰ Cable outlet
- ⑧⑩ Depth of the centering sleeve in the counter piece
- ⑧① Not included in the scope of delivery

Gripping force safety device, K/S

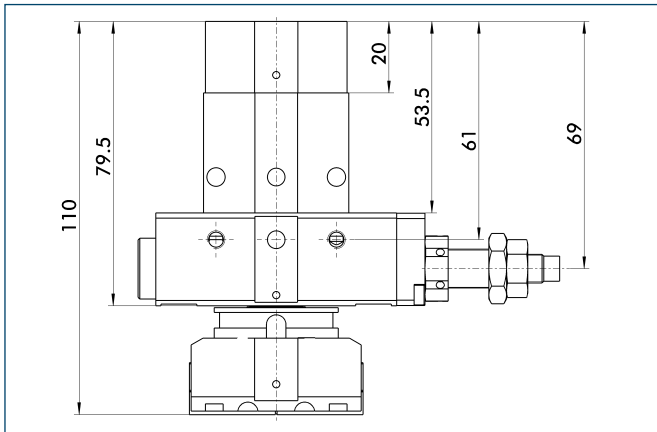

The mechanical gripping force safety device ensures that a minimum clamping force will be applied even if there is a drop in pressure. This acts as closing grip force for the K variant and as opening grip force for the S variant. The gripping force safety device can be installed without other components from the K variant into the S variant and vice versa. Besides this, the gripping force safety device can be used to increase gripping force or for single actuated gripping.

Rotation adapter D

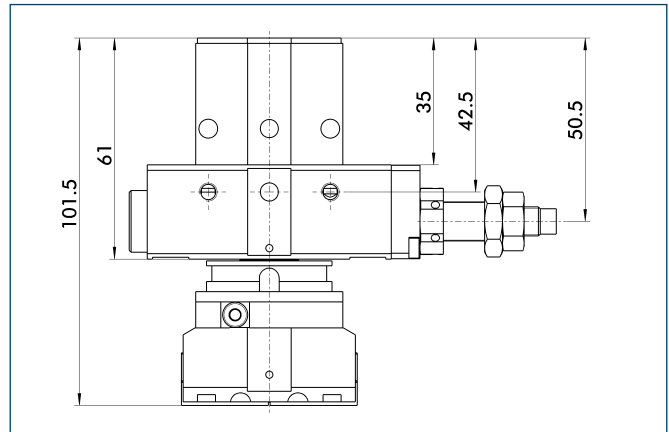

The two-part rotation adapter enables the gripping head to be continuously rotated in order to flexibly adjust the position of the gripper fingers on the workpiece. Only the clamping screw has to be released to do this. After the adjustment has been made, a hole can be drilled out to place a cylindrical pin or a fixing thread for clamping.

Gripping force safety device + rotation adapter Z/X

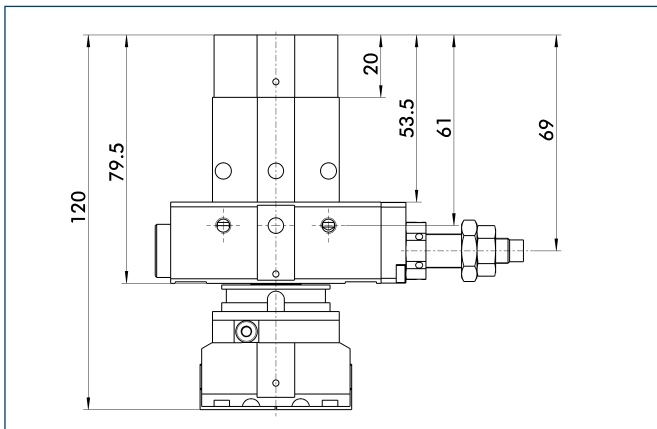

This variant combines the functions of the gripping force safety device with that of the rotation adapter. The gripping force safety device acts as closing grip force for the Z variant and as opening grip force for the X variant.

Sensor systems

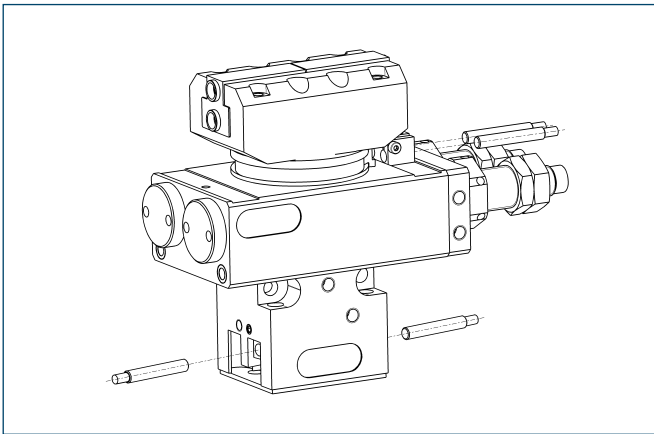

End-position monitoring:
Inductive proximity switch, can be directly mounted

Rotating motion

Designation	ID	Scope of delivery	Recommended product
RMNS 12-X	0313041	1 x bracket, 2 x sensors, 2 x operating targets	
RMNS 12-G	0313042	1 x bracket, 2 x sensors, 2 x operating targets, 2 x straight cable extensions	•
RMNS 12-W	0313043	1 x bracket, 2 x sensors, 2 x operating targets, 2 x angled cable extensions	

Gripping movement

Designation	ID	Scope of delivery	Recommended product
GMNS 16-X	0313333	Bracket, sensor	
GMNS 16-G	0313334	Bracket, sensor, straight cable extension	•
GMNS 16-W	0313335	Bracket, sensor, angled cable extension	

ⓘ Two sensors are needed for each gripper

 You can find further information and components for the accessories mentioned here in the "Accessories" part of the catalog.



Gripping force, I.D. gripping

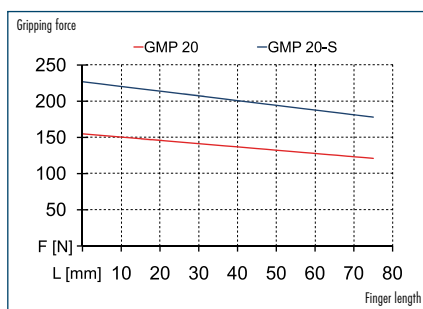

Gripping force, O.D. gripping

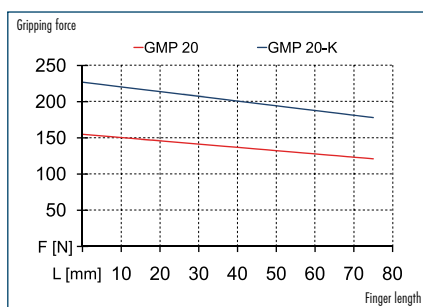

Moment load

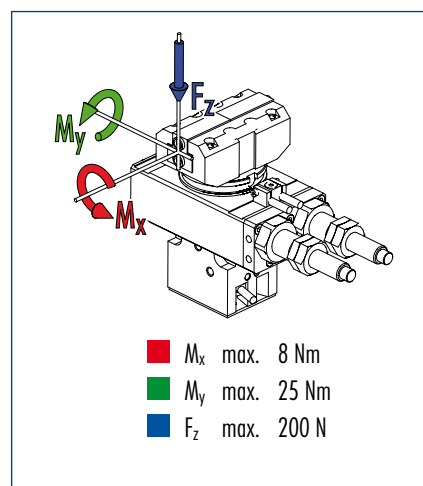

① Moments and forces apply per base jaw and may occur at the same time. M_y may occur additionally to the moment produced by the gripping force itself. For heavy structures or superstructures with high mass moment of inertia, limiting is necessary to ensure that rotary movement takes place without striking or bouncing.

Technical data

Designation		RP 1520	RP 1520-K	RP 1520-S
	ID	0313264	0313266	0313265
Stroke per jaw	[mm]	5	5	5
Closing grip force	[N]	150	220	
Opening grip force	[N]	150		220
Min. grip force applied by spring	[N]		70	70
Torque	[Nm]	0.76	0.76	0.76
Angle of rotation	[°]	190	190	190
End position adjustability	[°]	Continuous	Continuous	Continuous
Recommended workpiece weight	[kg]	0.75	0.75	0.75
Fluid consumption for gripping per cycle	[cm ³]	2.86	2.86	2.86
Fluid consumption for swiveling per cycle	[cm ³]	9.6	9.6	9.6
Mass	[kg]	0.92	1.0	1.0
Nominal operating pressure	[bar]	6	6	6
Minimum pressure for gripping	[bar]	3	5	5
Maximum pressure for gripping	[bar]	8	8	8
Minimum pressure for swiveling	[bar]	3	3	3
Maximum pressure for swiveling	[bar]	8	8	8
Closing time for gripping	[s]	0.03	0.025	0.04
Opening time for gripping	[s]	0.03	0.04	0.025
Max. permissible finger length	[mm]	75	75	75
IP rating		40	40	40
Min. ambient temperature	[°C]	5	5	5
Max. ambient temperature	[°C]	60	60	60
Repeat accuracy for gripping	[mm]	± 0.02	± 0.02	± 0.02
Repeat accuracy for swiveling	[°]	± 0.05	± 0.05	± 0.05

OPTIONS and their characteristics

Designation		RP 1520-D	RP 1520-Z	RP 1520-X
	ID	0313267	0313269	0313268
Mass	[kg]	0.98	1.06	1.06

Main views

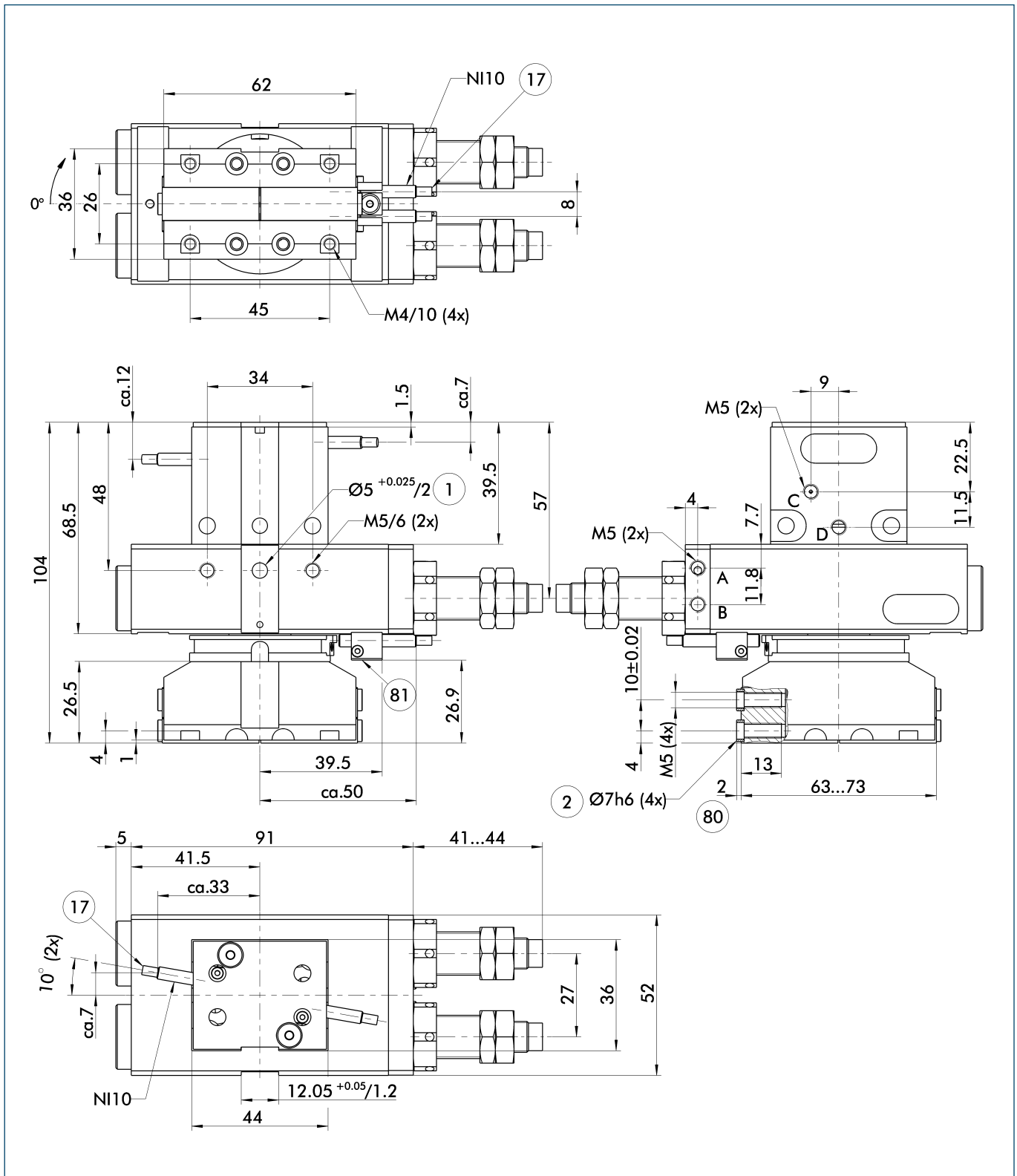

- A,a Main and direct connections, swivel unit, rotating to the right
- B,b Main and direct connections, swivel unit, rotating to the left
- C,c Main and direct connections, gripper open
- D,d Main and direct connections, gripper close
- ① Connections, gripping rotary module
- ② Finger connection
- ⑰ Cable outlet
- ⑧⑩ Depth of the centering sleeve in the counter piece
- ⑧⑪ Not included in the scope of delivery

Gripping force safety device, K/S

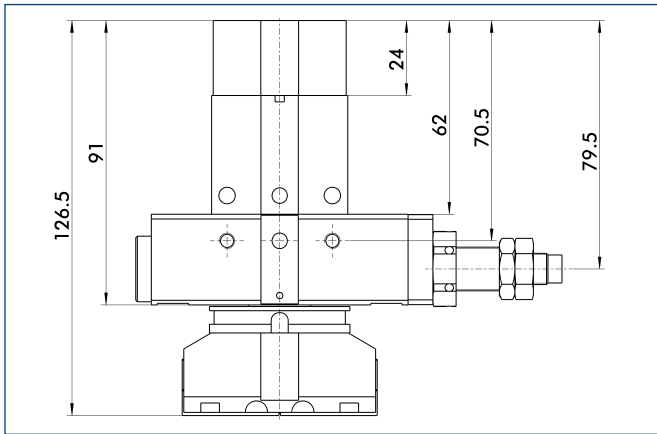

The mechanical gripping force safety device ensures that a minimum clamping force will be applied even if there is a drop in pressure. This acts as closing grip force for the K variant and as opening grip force for the S variant. The gripping force safety device can be installed without other components from the K variant into the S variant and vice versa. Besides this, the gripping force safety device can be used to increase

Rotation adapter D

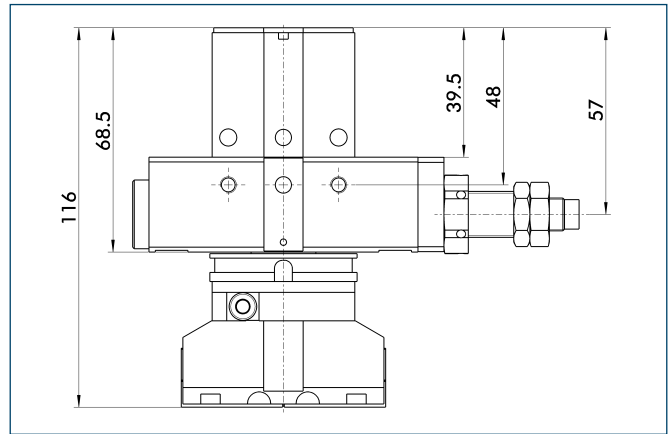

The two-part rotation adapter enables the gripping head to be continuously rotated in order to flexibly adjust the position of the gripper fingers on the workpiece. Only the clamping screw has to be released to do this. After the adjustment has been made, a hole can be drilled out to place a cylindrical pin or a fixing thread for clamping.

Gripping force safety device + rotation adapter Z/X

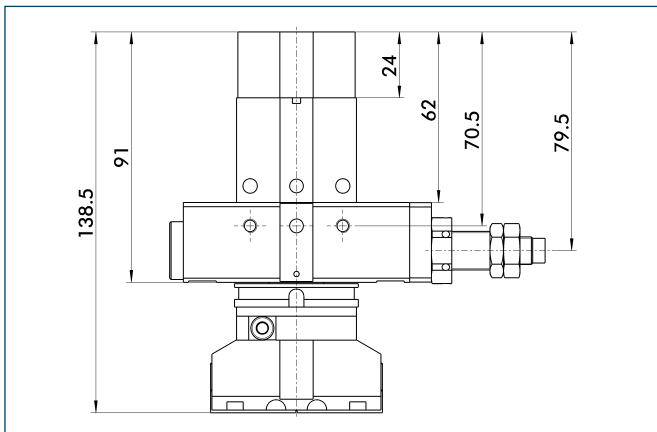

This variant combines the functions of the gripping force safety device with that of the rotation adapter. The gripping force safety device acts as closing grip force for the Z variant and as opening grip force for the X variant.

Sensor systems

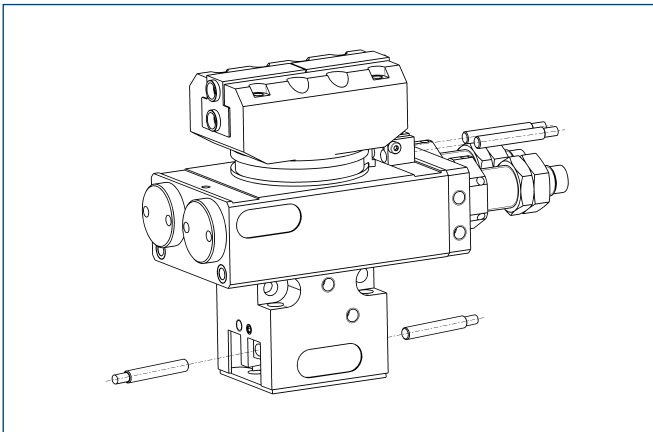

End-position monitoring:
Inductive proximity switch, can be directly mounted

Rotating motion

Designation	ID	Scope of delivery	Recommended product
RMNS 12-X	0313041	1 x bracket, 2 x sensors, 2 x operating targets	
RMNS 12-G	0313042	1 x bracket, 2 x sensors, 2 x operating targets, 2 x straight cable extensions	•
RMNS 12-W	0313043	1 x bracket, 2 x sensors, 2 x operating targets, 2 x angled cable extensions	

Gripping movement

Designation	ID	Scope of delivery	Recommended product
GMNS 16-X	0313333	Bracket, sensor	
GMNS 16-G	0313334	Bracket, sensor, straight cable extension	•
GMNS 16-W	0313335	Bracket, sensor, angled cable extension	

ⓘ Two sensors are needed for each gripper

 You can find further information and components for the accessories mentioned here in the “Accessories” part of the catalog.



Gripping force, I.D. gripping

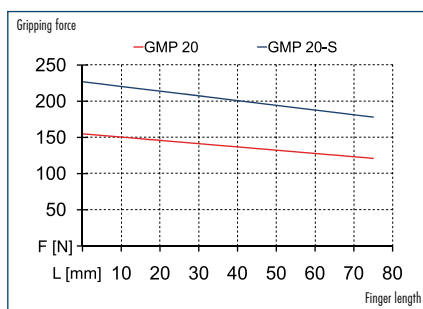

Gripping force, O.D. gripping

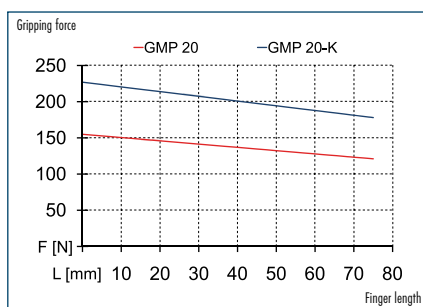

Moment load

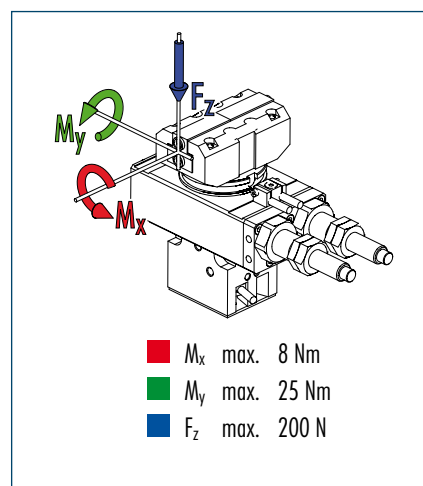

① Moments and forces apply per base jaw and may occur at the same time. M_y may occur additionally to the moment produced by the gripping force itself. For heavy structures or superstructures with high mass moment of inertia, limiting is necessary to ensure that rotary movement takes place without striking or bouncing.

Technical data

Designation		RP 2120	RP 2120-K	RP 2120-S
	ID	0313286	0313288	0313287
Stroke per jaw	[mm]	5	5	5
Closing grip force	[N]	150	220	
Opening grip force	[N]	150		220
Min. grip force applied by spring	[N]		70	70
Torque	[Nm]	1.9	1.9	1.9
Angle of rotation	[°]	190	190	190
End position adjustability	[°]	Continuous	Continuous	Continuous
Recommended workpiece weight	[kg]	0.75	0.75	0.75
Fluid consumption for gripping per cycle	[cm ³]	2.86	2.86	2.86
Fluid consumption for swiveling per cycle	[cm ³]	23.8	23.8	23.8
Mass	[kg]	1.5	1.58	1.58
Nominal operating pressure	[bar]	6	6	6
Minimum pressure for gripping	[bar]	3	5	5
Maximum pressure for gripping	[bar]	8	8	8
Minimum pressure for swiveling	[bar]	3	3	3
Maximum pressure for swiveling	[bar]	8	8	8
Closing time for gripping	[s]	0.03	0.025	0.04
Opening time for gripping	[s]	0.03	0.04	0.025
Max. permissible finger length	[mm]	75	75	75
IP rating		40	40	40
Min. ambient temperature	[°C]	5	5	5
Max. ambient temperature	[°C]	60	60	60
Repeat accuracy for gripping	[mm]	± 0.02	± 0.02	± 0.02
Repeat accuracy for swiveling	[°]	± 0.044	± 0.044	± 0.044

OPTIONS and their characteristics

Designation		RP 2120-D	RP 2120-Z	RP 2120-X
	ID	0313289	0313291	0313290
Mass	[kg]	1.56	1.64	1.64

Gripping force safety device, K/S

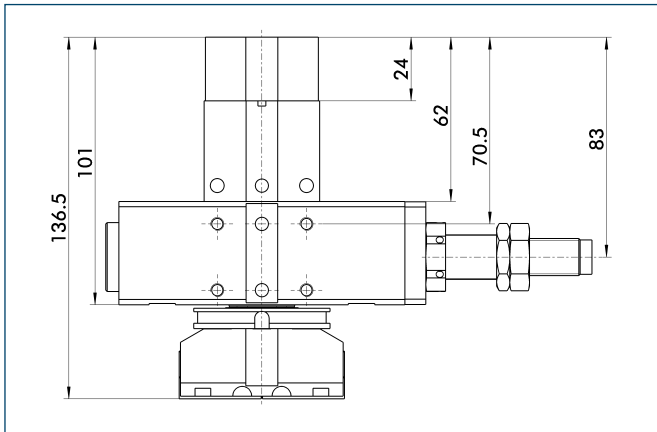

The mechanical gripping force safety device ensures that a minimum clamping force will be applied even if there is a drop in pressure. This acts as closing grip force for the K variant and as opening grip force for the S variant. The gripping force safety device can be installed without other components from the K variant into the S variant and vice versa. Besides this, the gripping force safety device can be used to increase gripping force or for single actuated gripping.

Rotation adapter D

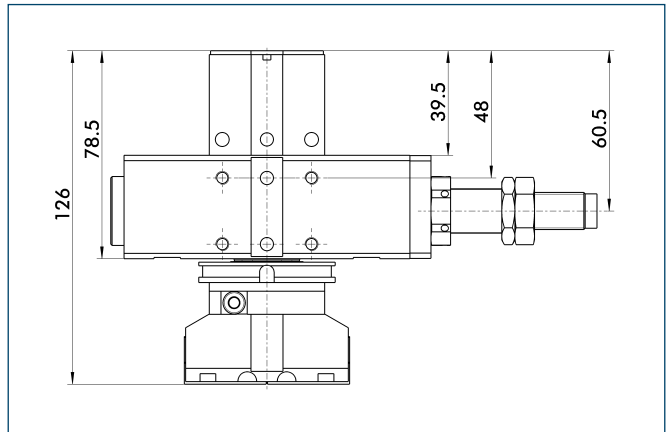

The two-part rotation adapter enables the gripping head to be continuously rotated in order to flexibly adjust the position of the gripper fingers on the workpiece. Only the clamping screw has to be released to do this. After the adjustment has been made, a hole can be drilled out to place a cylindrical pin or a fixing thread for clamping.

Gripping force safety device + rotation adapter Z/X

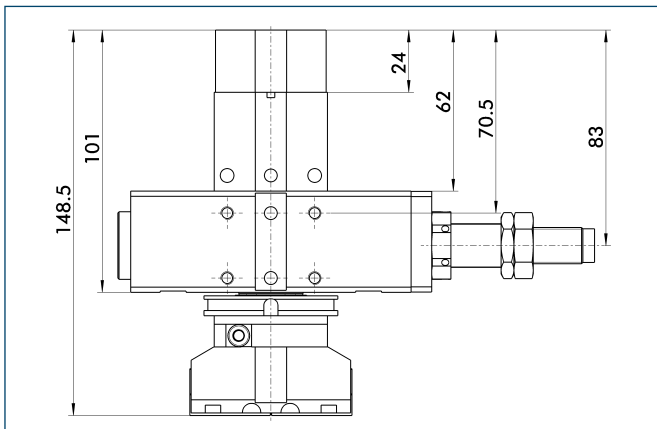

This variant combines the functions of the gripping force safety device with that of the rotation adapter. The gripping force safety device acts as closing grip force for the Z variant and as opening grip force for the X variant.

Sensor systems

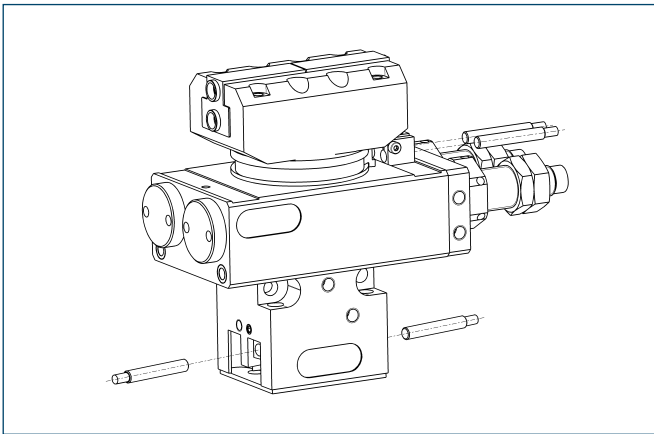

End-position monitoring:
Inductive proximity switch, can be directly mounted

Rotating motion

Designation	ID	Scope of delivery	Recommended product
RMNS 12-X	0313041	1 x bracket, 2 x sensors, 2 x operating targets	
RMNS 12-G	0313042	1 x bracket, 2 x sensors, 2 x operating targets, 2 x straight cable extensions	•
RMNS 12-W	0313043	1 x bracket, 2 x sensors, 2 x operating targets, 2 x angled cable extensions	

Gripping movement

Designation	ID	Scope of delivery	Recommended product
GMNS 16-X	0313333	Bracket, sensor	
GMNS 16-G	0313334	Bracket, sensor, straight cable extension	•
GMNS 16-W	0313335	Bracket, sensor, angled cable extension	

ⓘ Two sensors are needed for each gripper

 You can find further information and components for the accessories mentioned here in the “Accessories” part of the catalog.



Gripping force, I.D. gripping

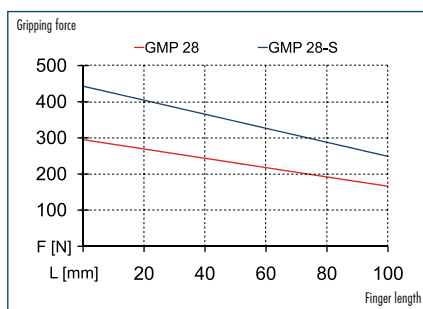

Gripping force, O.D. gripping

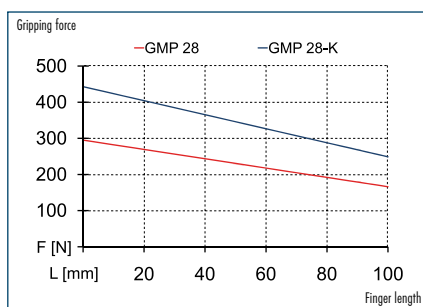

Moment load

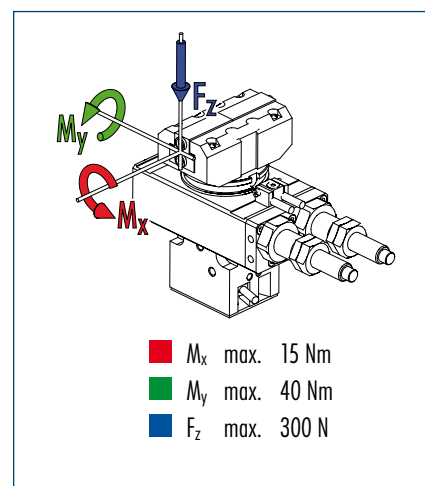

① Moments and forces apply per base jaw and may occur at the same time. M_y may occur additionally to the moment produced by the gripping force itself. For heavy structures or superstructures with high mass moment of inertia, limiting is necessary to ensure that rotary movement takes place without striking or bouncing.

Technical data

Designation		RP 2128	RP 2128-K	RP 2128-S
	ID	0313308	0313310	0313309
Stroke per jaw	[mm]	8	8	8
Closing grip force	[N]	280	420	
Opening grip force	[N]	280		420
Min. grip force applied by spring	[N]		140	140
Torque	[Nm]	1.9	1.9	1.9
Angle of rotation	[°]	190	190	190
End position adjustability	[°]	Continuous	Continuous	Continuous
Recommended workpiece weight	[kg]	1.4	1.4	1.4
Fluid consumption for gripping per cycle	[cm ³]	9.05	9.05	9.05
Fluid consumption for swiveling per cycle	[cm ³]	23.8	23.8	23.8
Mass	[kg]	1.78	1.94	1.94
Nominal operating pressure	[bar]	6	6	6
Minimum pressure for gripping	[bar]	3	5	5
Maximum pressure for gripping	[bar]	8	8	8
Minimum pressure for swiveling	[bar]	3	3	3
Maximum pressure for swiveling	[bar]	8	8	8
Closing time for gripping	[s]	0.05	0.04	0.06
Opening time for gripping	[s]	0.05	0.06	0.04
Max. permissible finger length	[mm]	100	100	100
IP rating		40	40	40
Min. ambient temperature	[°C]	5	5	5
Max. ambient temperature	[°C]	60	60	60
Repeat accuracy for gripping	[mm]	± 0.02	± 0.02	± 0.02
Repeat accuracy for swiveling	[°]	± 0.044	± 0.044	± 0.044

OPTIONS and their characteristics

Designation		RP 2128-D	RP 2128-Z	RP 2128-X
	ID	0313311	0313313	0313312
Mass	[kg]	1.84	2.02	2.02

Main views

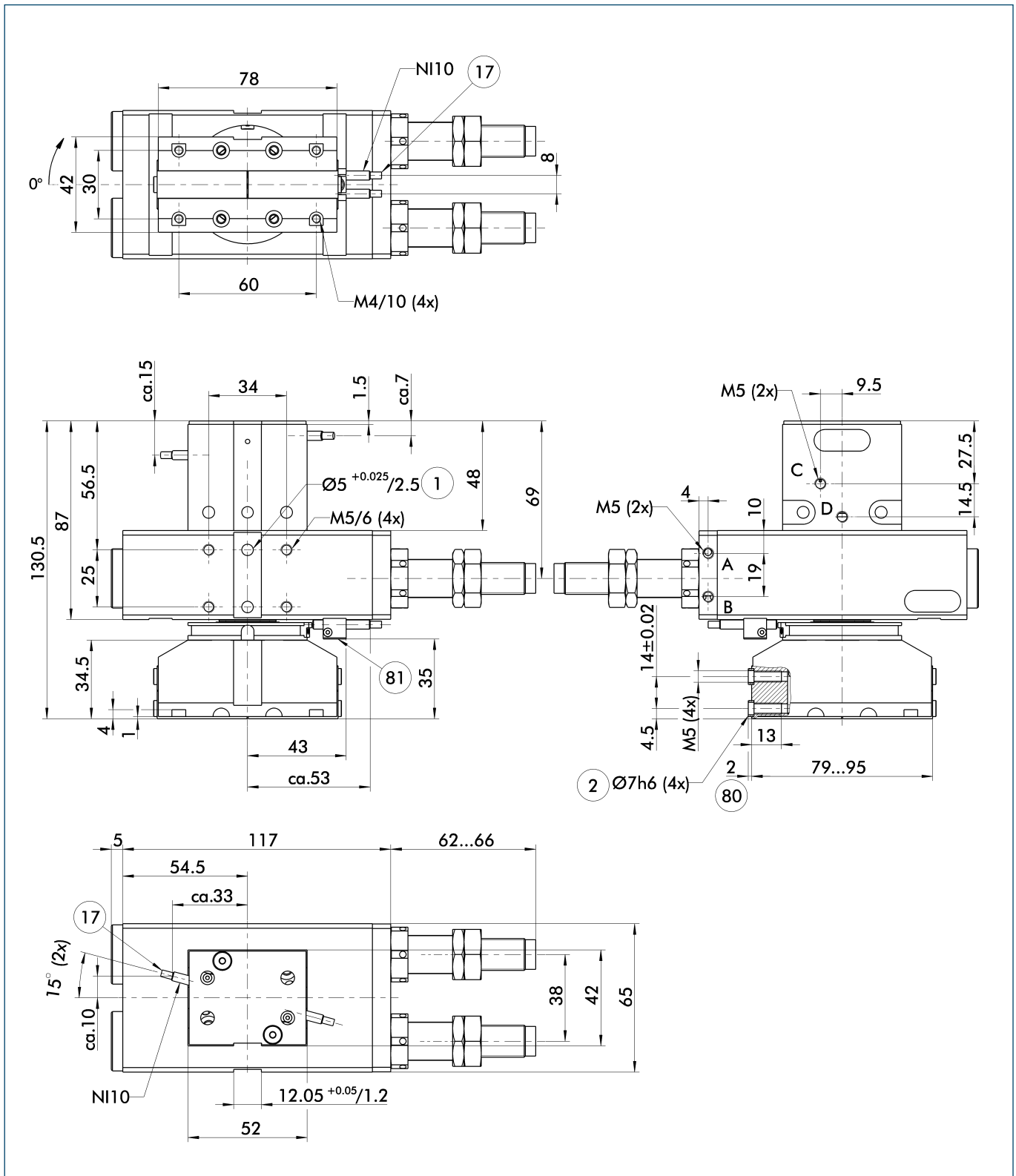

- A,a Main and direct connections, swivel unit, rotating to the right
- B,b Main and direct connections, swivel unit, rotating to the left
- C,c Main and direct connections, gripper open
- D,d Main and direct connections, gripper close
- ① Connections, gripping rotary module
- ② Finger connection
- ①⑦ Cable outlet
- ⑧⑩ Depth of the centering sleeve in the counter piece
- ⑧⑩ Not included in the scope of delivery

Gripping force safety device, K/S

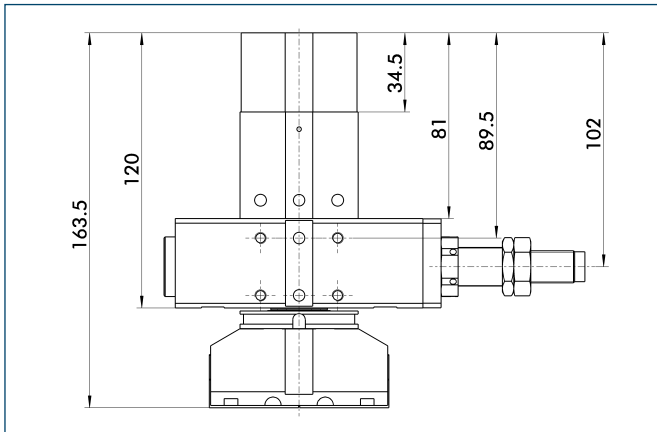

The mechanical gripping force safety device ensures that a minimum clamping force will be applied even if there is a drop in pressure. This acts as closing grip force for the K variant and as opening grip force for the S variant. The gripping force safety device can be installed without other components from the K variant into the S variant and vice versa. Besides this, the gripping force safety device can be used to increase gripping force or for single actuated gripping.

Rotation adapter D

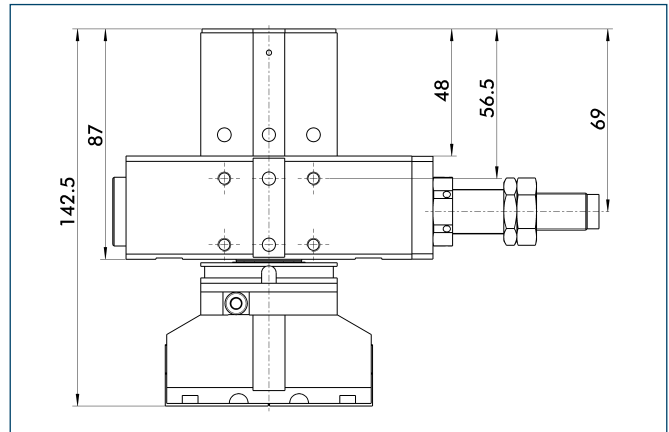

The two-part rotation adapter enables the gripping head to be continuously rotated in order to flexibly adjust the position of the gripper fingers on the workpiece. Only the clamping screw has to be released to do this. After the adjustment has been made, a hole can be drilled out to place a cylindrical pin or a fixing thread for clamping.

Gripping force safety device + rotation adapter Z/X

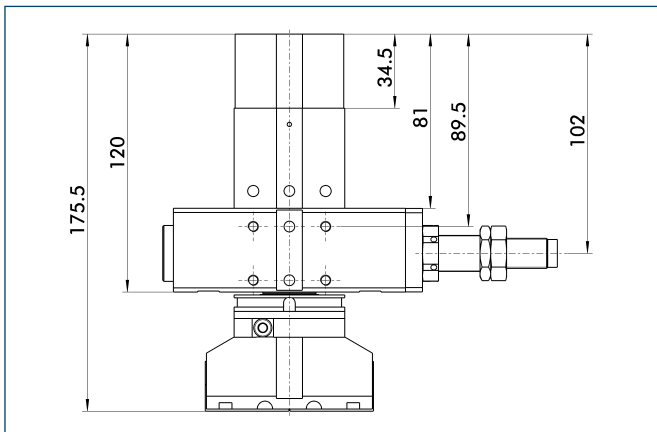

This variant combines the functions of the gripping force safety device with that of the rotation adapter. The gripping force safety device acts as closing grip force for the Z variant and as opening grip force for the X variant.

Sensor systems

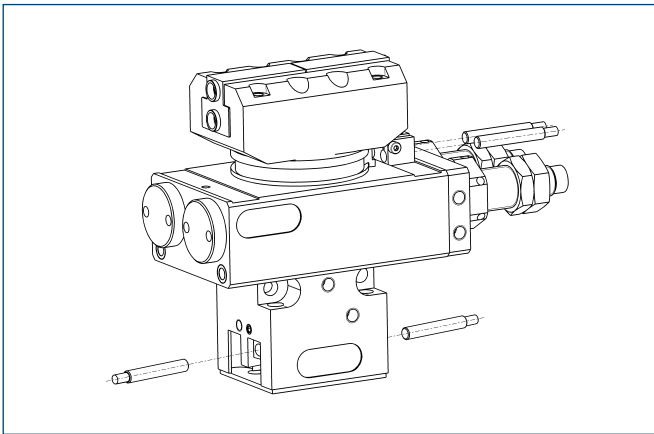

End-position monitoring:
Inductive proximity switch, can be directly mounted

Rotating motion

Designation	ID	Scope of delivery	Recommended product
RMNS 12-X	0313041	1 x bracket, 2 x sensors, 2 x operating targets	
RMNS 12-G	0313042	1 x bracket, 2 x sensors, 2 x operating targets, 2 x straight cable extensions	•
RMNS 12-W	0313043	1 x bracket, 2 x sensors, 2 x operating targets, 2 x angled cable extensions	

Gripping movement

Designation	ID	Scope of delivery	Recommended product
GMNS 28-X	0313336	Bracket, sensor	
GMNS 28-G	0313337	Bracket, sensor, straight cable extension	•
GMNS 28-W	0313338	Bracket, sensor, angled cable extension	

ⓘ Two sensors are needed for each gripper

 You can find further information and components for the accessories mentioned here in the “Accessories” part of the catalog.