

Reed Switches

Reed switches are mechanical switches that react to the presence of magnetic fields (magnets). They are frequently used as low-price alternatives to electronic magnetic switches (MMS).



Function description

Reed switches consist of tiny, metal contacts (reeds). Under the influence of a magnetic field, they bend and touch one another, closing the contact.

Your advantages and benefits

Economical

for cost-saving applications

Installed in the sensor slot

for space-saving, simple and fast assembly

Version with connector

for easy, rapid replacement of the extension cable

Ultra-flexible PUR cable

for a long life and resistance to many chemicals

Application example

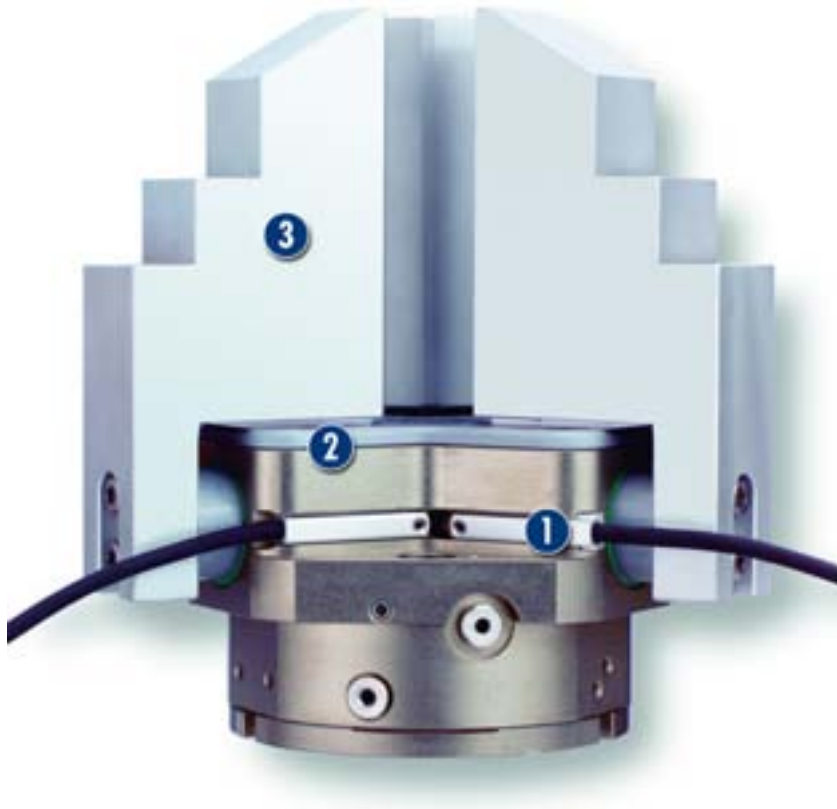

1 RMS Reed Switches for mounting in the C-slot of the gripper

2 Sealed 3-Finger Centric Gripper

3 Workpiece-specific Gripper Fingers

Area of application

For monitoring of gripping and rotary modules, linear modules and robot accessories. Reed switches from SCHUNK detect metals without contact or wear and are resistant to dust and humidity. Magnetic switches are fitted in slots and therefore do not form any additional interfering contours. Please note that not all SCHUNK products with sensor slot can be monitored using low-cost reed switches.

General information

Material

Sensor housing: PA in the RMS 22 and RZN, stainless steel in the RMS 80
Cable: PUR sheath

Fastening

Clamps in sensor slot (RMS 22/RZN) / brackets (RMS 80)

Protection class according to DIN 40050

IP 67 in connected condition for use in clean or dusty environments or in the event of contact with water. Contact with other media (cooling lubricants, acidic or caustic substances, etc.) frequently does not impair the function, but this cannot be guaranteed by SCHUNK.

Warranty

24 months

Notes

SCHUNK gripper, rotary and linear modules and robot accessory components that are to be monitored by slot-fitted reed switches can generally only be reliably monitored with the appropriate reed switches from SCHUNK. Sensors and products are matched on the basis of the relationships between the parameters type and field strength of the magnet, distance, wall thickness and wall material of the magnet and the sensor, and the orientation and sensitivity of the sensor itself. For this reason, sensors from other manufacturers employed in SCHUNK products rarely give satisfactory switching results.

Circuit diagram of closer

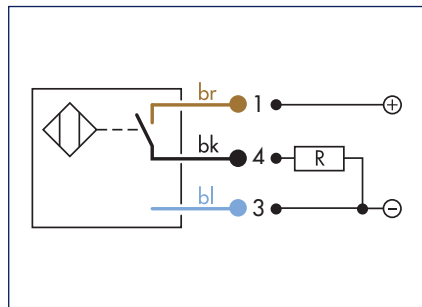
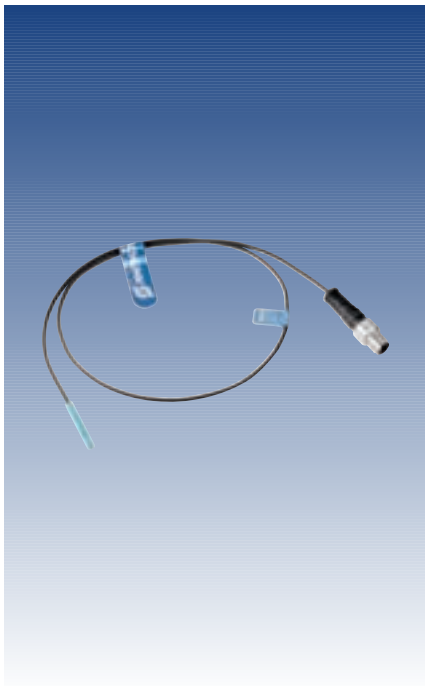

Technical data

Description	ID	RZN 1-05ZRS-KRD
		0312991
Switching function		Closer
Switching method		PNP, NPN
Cable length	[cm]	50.0
Cable connector/cable end		M8
Type of voltage		DC
Nominal voltage	[V]	24.0
Min. voltage	[V]	10.0
Max. voltage	[V]	30.0
Voltage drop	[V]	0.0
Max. power on contact	[A]	0.5
Min. ambient temperature	[°C]	-25.0
Max. ambient temperature	[°C]	70.0
Typical switching time	[s]	0.002
IP class (sensor)		67
IP class (connector, plugged in)		67
LED display on sensor		Yes
Cable diameter	[mm]	2.1
Min. bending radius (dynamic)	[mm]	25.0
Min. bending radius (static)	[mm]	12.0
No. of wires		3
Wire cross section	[mm ²]	

RZN sensor

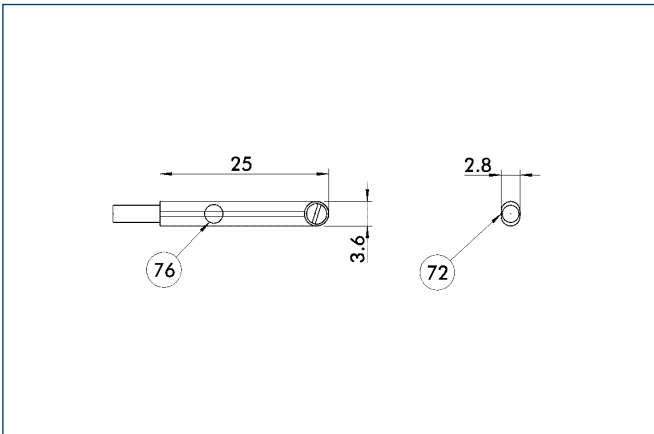

- ⑦② Active sensor surface
- ⑦⑥ LED

M8 connector

