

Stationäres 3-Backen-Spannfutter
ROTA NCH 140/R
hydraulisch

Stationary 3-Jaw-Clamping-Chuck
ROTA NCH 140/R
hydraulic



Bezeichnung Type	Ident.-Nr. Id.-No.	Hub/Backe Stroke/Jaw	Spannkraft* Clamping force*	Druck Pressure	Ölverbrauch pro Doppelhub Oil use per double stroke	Öffnungszeit bei 60 bar Opening time at 60 bar	Schließzeit bei 60 bar Closing time at 60 bar	Gewicht Weight	Wiederhol- genauigkeit** Repeatability**	Max. Backen- höhe Max. jaw height
ROTA NCH 140/3	0450112	4 mm	30000 N	60 bar	85 cm ³	0.29 s	0.28 s	9 kg	0.01 mm	40 mm

* Spannkraft ist die arithmetische Summe der an den Spannbacken auftretenden Einzelkräfte im Abstand „H“ bei 6 bar
** Streuung der Endlagen bei 100 aufeinanderfolgenden Hübem

* Clamping force is the arithmetic sum of the individual forces occurring at the jaws, distance "H" at 6 bar
** After 100 consecutive strokes to end positions

Maximal zulässige Kräfte und Momente an den Spannbacken, die zusätzlich zur Spannkraft wirken.

Maximum admissible forces and moments at the chuck jaws, which may occur additionally to the clamping force.

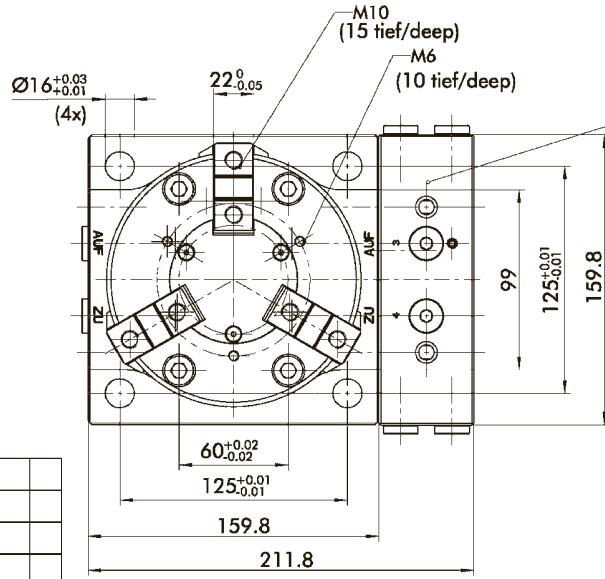
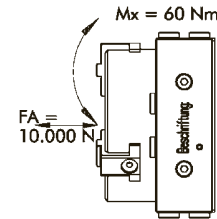
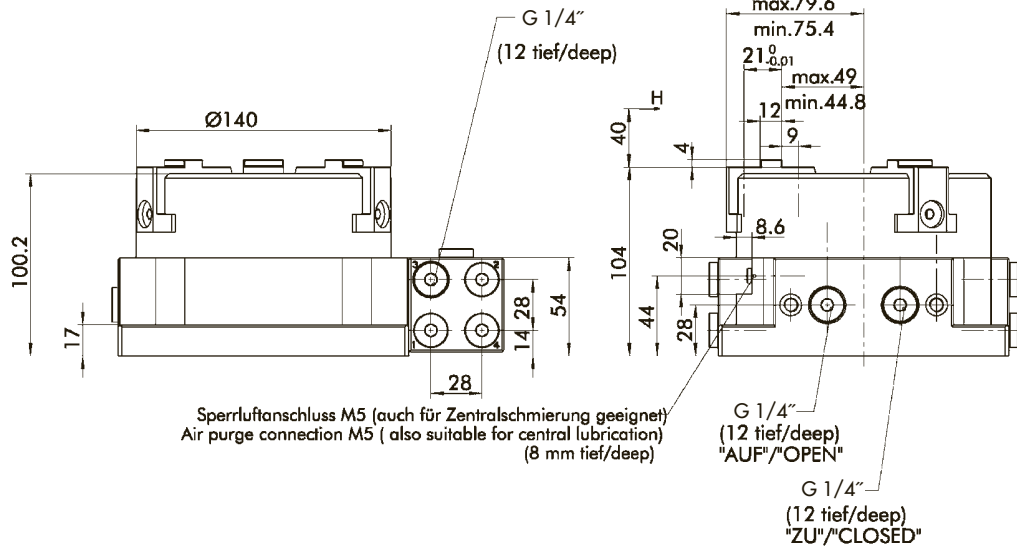
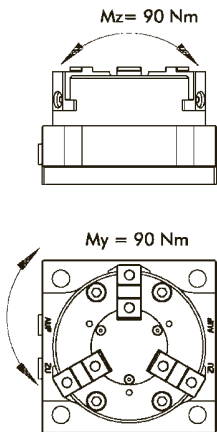

Anschlussleiste/
Connector
(Id.-No. 0450149)
Nicht im Lieferumfang
enthalten/
ordered separately

Anschlussleiste (Ident.-Nr. 0450149)
Connector (Id.-No. 0450149)

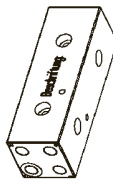

Spannkraftdiagramm /
Clamping force diagram

