

**Aufsatzbackenrohlinge
Type KTR 140**

passend für ROTA-NCH 140

**Top Jaw Blanks
Type KTR 140**

suitable for ROTA NCH 140

Bezeichnung Type	Ident.-Nr. Id.-No.	passend für suitable for
KTR 140/2	0450147	ROTA NCH 140/2
KTR 140/3	0450146	ROTA NCH 140/3



Aufsatzbackenrohling

Werkstoff: 16 MnCr5, härtbar
Ausführung: gebohrt und gesenkt für Schraube M10
Aufnahme: über Kreuzversatz (Nut)

Top Jaw Blanks

Material: 16 MnCr5, hardenable
Design: drilled, countersunk for M10 screw
Mounting: via slot and tenon (slot)

**Spannbereich /
Clamping ranges**

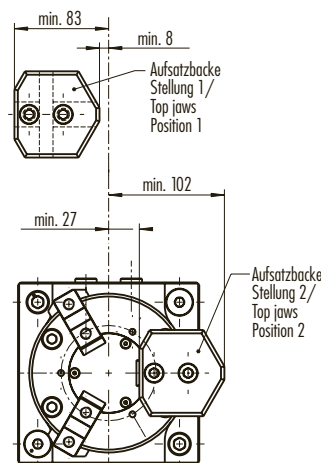
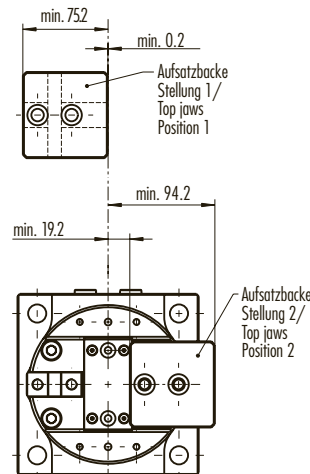

**Maße 140/2
Dimensions 140/2**

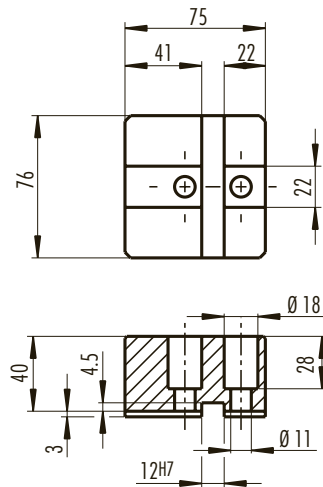

**Maße 140/3
Dimensions 140/3**

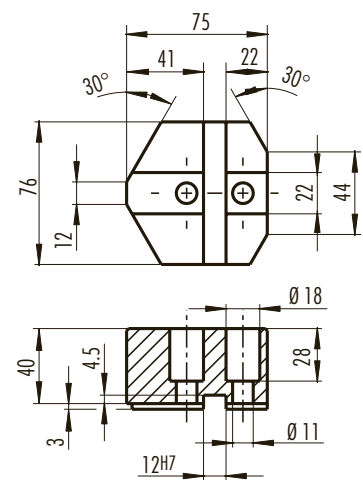

**Anordnungsmöglichkeiten der Aufsatzbackenrohlinge /
Arrangement of the top jaw blanks, mounting possibilities**

Draufsicht - Top view

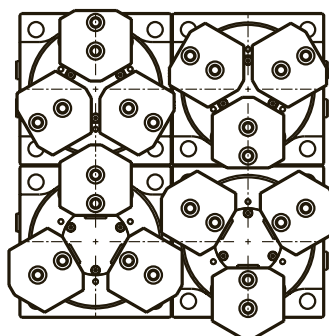

3D-Ansicht - 3D-View

