

SCHUNK 



SUPERIOR!

Long, slim and can be clamped in no time at all

T | E | N | D | O® SVL Tool Extension
One of a kind! With Hydraulic Expansion Technology



T | E | N | D | O[®] SVL

Hydraulic Expansion Technology expands

The innovative TENDO SVL Tool Extension with optimum interfering contours from SCHUNK sets new standards in regard to set-up time and costs. The extension can be clamped in every type of toolholder in no time at all. The TENDO SVL has been designed for and is suitable for the precise machining of difficult to access areas.

TENDO SVL is unrivaled:

- Clamp in seconds without peripheral equipment. For instance, additional costs for heat shrinking stations are eliminated
- Micron precise tool changes in seconds, even in the machine
- Unique and highly flexible tool extension in the field of hydraulic expansion technology
 - Can be used in nearly every precision toolholder irrespective of the spindle interface
 - Flexible clamping range due to the use of intermediate sleeves
- Absolutely maintenance-free and resistant to contamination thanks to its one-piece design

Benefit from the leading expert in toolholding and workholding:

TENDO Hydraulic Expansion Technology guarantees quality:

- Excellent vibration dampening guarantees optimum workpiece surfaces
- Optimum run-out accuracy, 0.006 mm at an L₁ dimension of 150 mm
- Internal coolant supply for optimized machining conditions
- Length adjustment can be actuated axially
- Fine balanced with balancing grade G 2.5 at 25000 rpm as standard and thus offers maximum smooth running
- All customary shank types can be clamped



Superior!

The precise set-up time killer

The TENDO SVL Tool Extension is first-rate whenever and wherever small interference contour at maximum precision and efficiency are required.

TENDO SVL even sets standards during machining. Reliable tool clamping, ensures a safe clamping during boring, reaming, chamfering and milling.

Your absolute advantage: A single TENDO extension can be fitted with a variety of standard tools, dispensing with the need for expensive special tools. Thanks to its precise concentricity, excellent vibration dampening and internal coolant supply, the innovative and highly flexible extension also guarantees outstanding workpiece machining results and long service life.



1 Optimized interference contours pay off!

Bores on deep parts in fixture construction.

2 Tried and tested in die construction!

TENDO SVL milling hard-to-reach contours.

3 Integration saves time:

Easy and fast tool changes

The clamping screw, which can be operated radially, is integrated in the extension and guarantees the easiest handling. It is simply screwed in to the stop using an Allen key, and the tool is clamped.

Tip from the professionals

When things get a bit tight in the machine room, TENDO SVL and TENDO ES – a brilliant combination.

The space-saving TENDO ES with no interference contour is the powerhouse amongst hydraulic expansion toolholders. The mounting shank is positioned directly in the spindle. The result: Optimum amount of available space in cramped machine rooms.

The combination of the TENDO SVL Tool Extension and the TENDO ES now makes it possible to efficiently machine workpieces with demanding geometries, whose proportions actually exceed the limits of the machine room. All that in a single set-up!

In short: Interference contours are bypassed with the TENDO SVL Tool Extension. The extremely short TENDO ES Hydraulic Expansion Toolholder frees up space between the spindle and workpiece.

We would be happy to advise you.



TENDO SVL Extensions can be used trouble-free in nearly all toolholding systems.

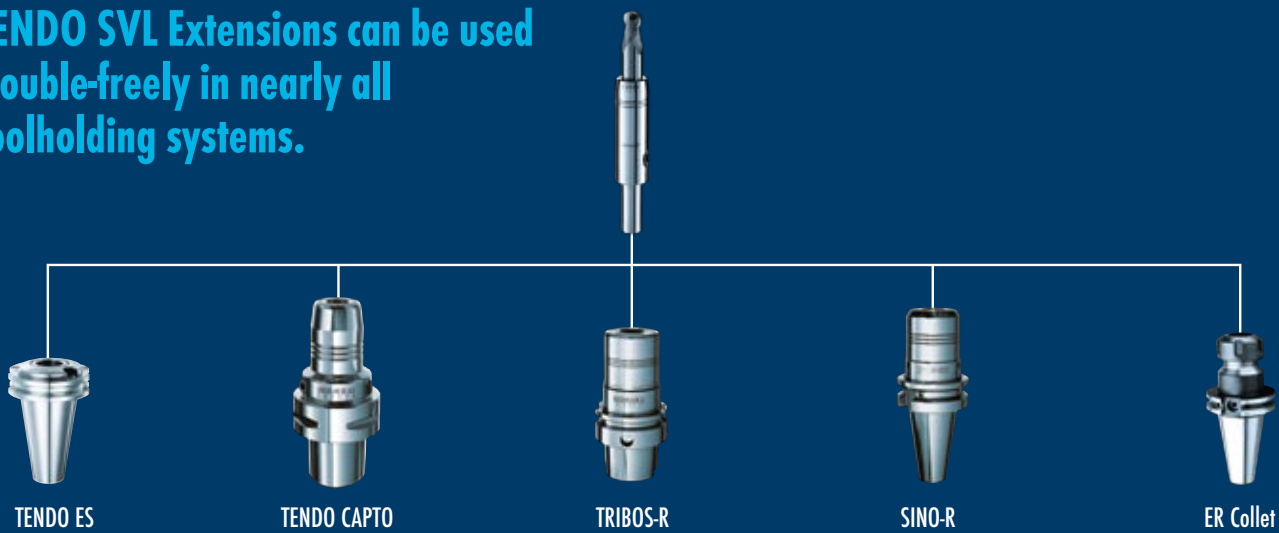

Technical data TENDO SVL

Type	ID	L ₁	L ₂	L ₃	L ₅	L ₆	L ₉	D ₁	D ₂	D ₃	D ₅
TENDO SVL 150 D12	206304	150	46	10	4	30,3	100	12	21	20	25
TENDO SVL 150 D20	206306	150	51	10	4	36,2	100	20	29	20	31,5
TENDO SVL 200 D20	206326	200	51	10	4	36,2	90	20	29	32	31,5

Intermediate sleeves

Available in all sizes
For diameter ranges of
12 and 20 mm

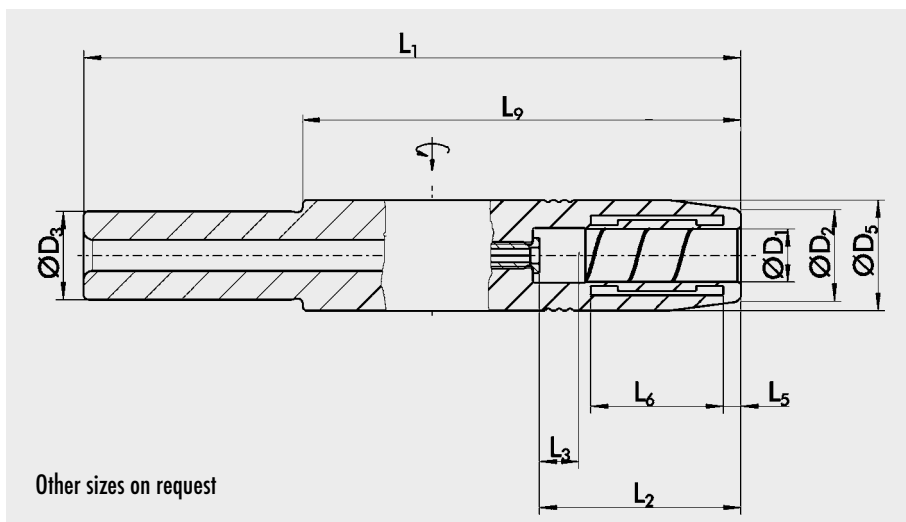

Other sizes on request



Copy fax reply, complete and fax to +49-7133-103-2239

Please contact me

for a consultation by phone

for a personal consultation from the SCHUNK area sales manager

Company	Name	Department
Street	ZIP	City
Phone	Fax	E-mail