

TRIBOS SPF-Mini ISO 10

für automatischen Werkzeugwechsel

TRIBOS SPF-Mini ISO 10

for automatic tool change

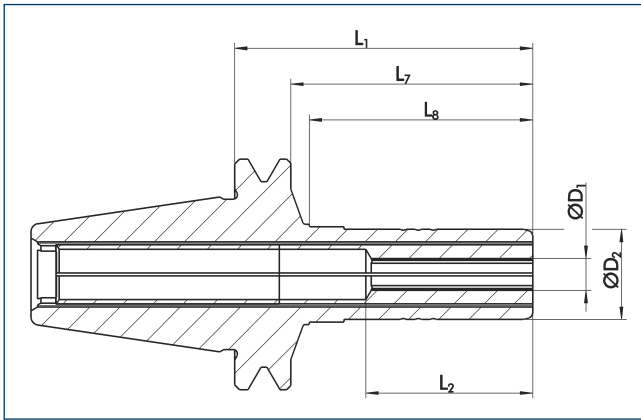

SK-ISO



Technische Daten

Technical data

D ₁ [mm]	ID		D ₂ [mm]	L ₁ [mm]	L ₂ [mm]	L ₇ [mm]	L ₈ [mm]	m [kg]	SRE ID
1.0	0225901	○	9.0	30.0	16.8	24.35	22.5	0.25	0201971
1.5	0225902	○	9.0	30.0	16.8	24.35	22.5	0.06	0201971
2.0	0225903	○	9.0	30.0	16.8	24.35	22.5	0.06	0201971
2.5	0225904	○	9.0	30.0	16.8	24.35	22.5	0.06	0201971
3.0	0225905	○	9.0	30.0	16.8	24.35	22.5	0.06	0201971

Verfügbarkeit: ● lieferbar ab Lager ▲ kurzfristig lieferbar ○ auf Anfrage

Availability: ● available ex stock ▲ short lead time ○ on request

i Optimal für die leichte Zerspanung – Radialkräfte beachten
Weitere Größen und Sonderausführungen auf Anfrage erhältlich

i Optimal for light machine cutting – consider radial forces
Additional sizes and special designs available on request



Spannvorrichtungen
siehe ab Seite 326
Clamping devices
see from page 326



Reduziereinsätze
siehe ab Seite 330
Reduction inserts
see from page 330



Längenmessgeräte
siehe ab Seite 336
Length measuring devices
see from page 336

TRIBOS SPF-Mini SK 30

für automatischen Werkzeugwechsel

TRIBOS SPF-Mini SK 30

for automatic tool change

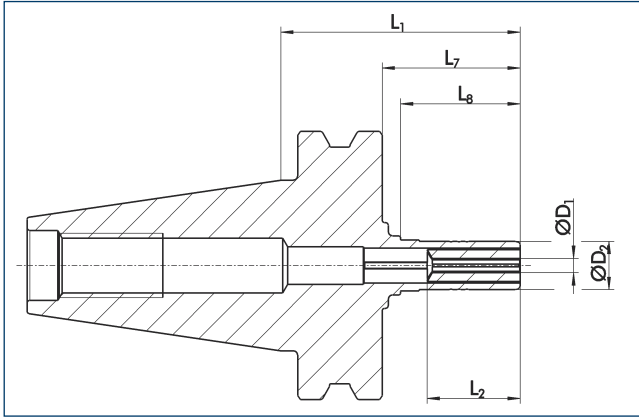

SK-ISO



<math>< 0.003 \text{ mm}</math>



42000 min⁻¹



✓



✓



✓



✓



Technische Daten

Technical data

D ₁ [mm]	ID		D ₂ [mm]	L ₁ [mm]	L ₂ [mm]	L ₇ [mm]	L ₈ [mm]	M _{min} [Nm]	m [kg]	SRE ID
1.0	0225961	○	9.0	45.0	17.5	26.0	22.5	3.0	0.25	0201971
1.5	0225962	○	9.0	45.0	17.5	26.0	22.5	4.0	0.25	0201971
2.0	0225963	○	9.0	45.0	17.5	26.0	22.5	6.0	0.25	0201971
2.5	0225964	○	9.0	45.0	17.5	26.0	22.5	10.0	0.25	0201971
3.0	0225965	○	9.0	45.0	17.5	26.0	22.5	15.0	0.25	0201971

Verfügbarkeit: ● lieferbar ab Lager ▲ kurzfristig lieferbar ○ auf Anfrage

Availability: ● available ex stock ▲ short lead time ○ on request

i Optimal für die leichte Zerspanung – Radialkräfte beachten
Weitere Größen und Sonderausführungen auf Anfrage erhältlich

i Optimal for light machine cutting – consider radial forces
Additional sizes and special designs available on request



Spannvorrichtungen

siehe ab Seite 326

Clamping devices

see from page 326



Reduziereinsätze

siehe ab Seite 330

Reduction inserts

see from page 330



Längenmessgeräte

siehe ab Seite 336

Length measuring devices

see from page 336