



### TENDO Hydro-Dehnspannfutter Aufnahme ähnlich SK 50

#### Kraftbetätigte Spannung

Rundlaufgenauigkeit: < 0,003 mm  
Einsatz von Zwischenbüchsen möglich

### TENDO Hydraulic Expansion Toolholder Mounting similar SK 50

#### Power actuated clamping

Run out accuracy: < 0.003 mm  
Use of intermediate sleeves possible

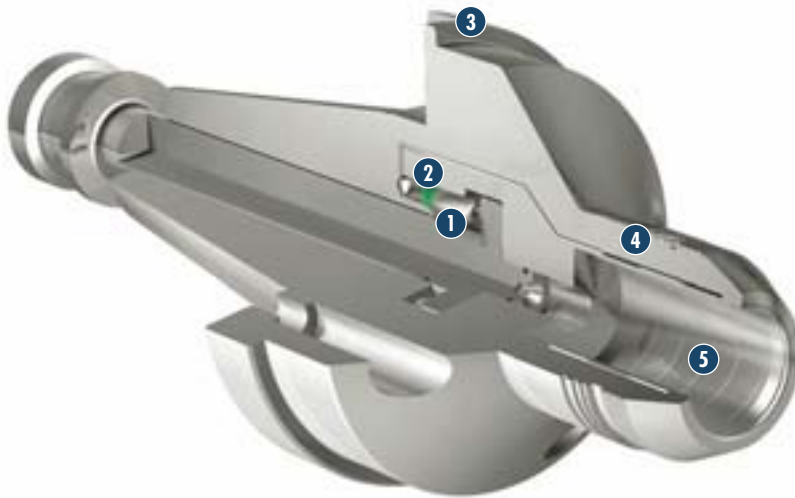

- 1 Spannkolben
  - 2 Dichtelement
  - 3 Anschraubflansch
  - 4 Dehnkammer
  - 5 Schmutzablauffrille
- 
- 1 Clamping piston
  - 2 Sealing element
  - 3 Screw-down flange
  - 4 The chamber system
  - 5 Groove for dirt removal

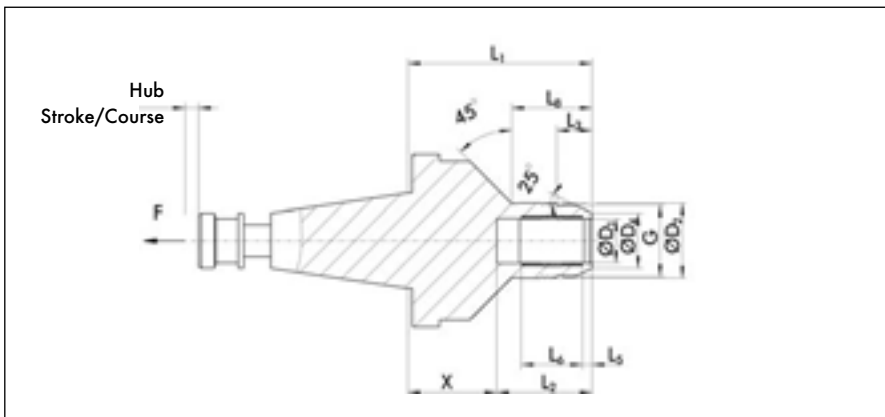

Zwischenbüchsen-sicherung mit Überwurfmutter  
Locking of intermediate sleeve with cap nut

Spann-Ø D <sub>1</sub> * Clamp. Ø D <sub>1</sub> * [mm]	ID		D <sub>2</sub> [mm]	D <sub>4</sub> [mm]	X [mm]	L <sub>1</sub> [mm]	L <sub>2</sub> [mm]	L <sub>3</sub> [mm]	L <sub>5</sub> [mm]	L <sub>6</sub> [mm]	L <sub>8</sub> [mm]	G	m [kg]
12	0206756	○	36.5	21.5	76	130	54	24.5	5.5	31.5	54	M34 x 1.5	7.0
20	0206757	○	42	28	66	130	64	24.5	5.5	31.5	54	M40 x 1.5	7.1
22	0206758	○	44	30	71	135	64	24.5	5.5	31.5	54	M42 x 1.5	7.2
32	0206759	○	54	40	70	140	70	24.5	6	42.5	66.5	M52 x 1.5	7.5

\* Für Werkzeugtoleranz h7 bei Ø 12 mm bis Ø 32 mm, andere Abmessungen auf Anfrage!

\* Tool tolerance h7 for Ø 12 mm to Ø 32 mm, other dimensions on request!

Verfügbarkeit: ● lieferbar ab Lager ▲ kurzfristig lieferbar ○ auf Anfrage

Availability: ● available ex stock ▲ short lead time ○ on request