



Hydro-Dehnspannfutter ähnlich SK 50

Kraftbetätigte Spannung

Rundlaufgenauigkeit: < 0,003 mm
Einsatz von Zwischenbüchsen möglich

Hydraulic Expansion Toolholder similar SK 50

Power actuated clamping

Run out accuracy: < 0.003 mm
Use of intermediate sleeves possible

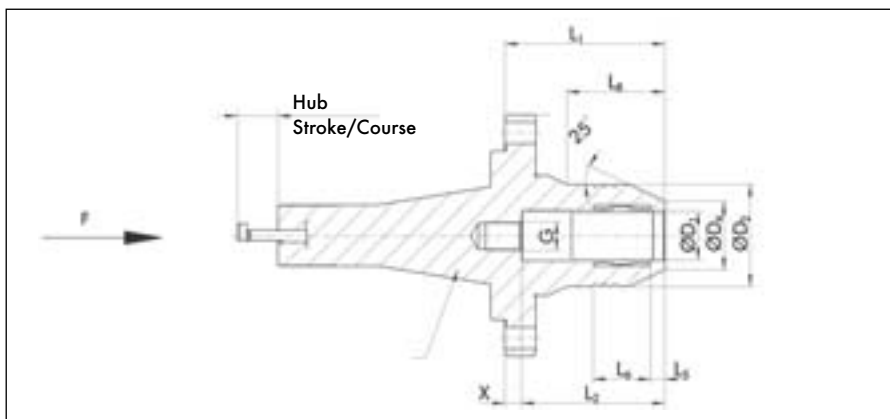
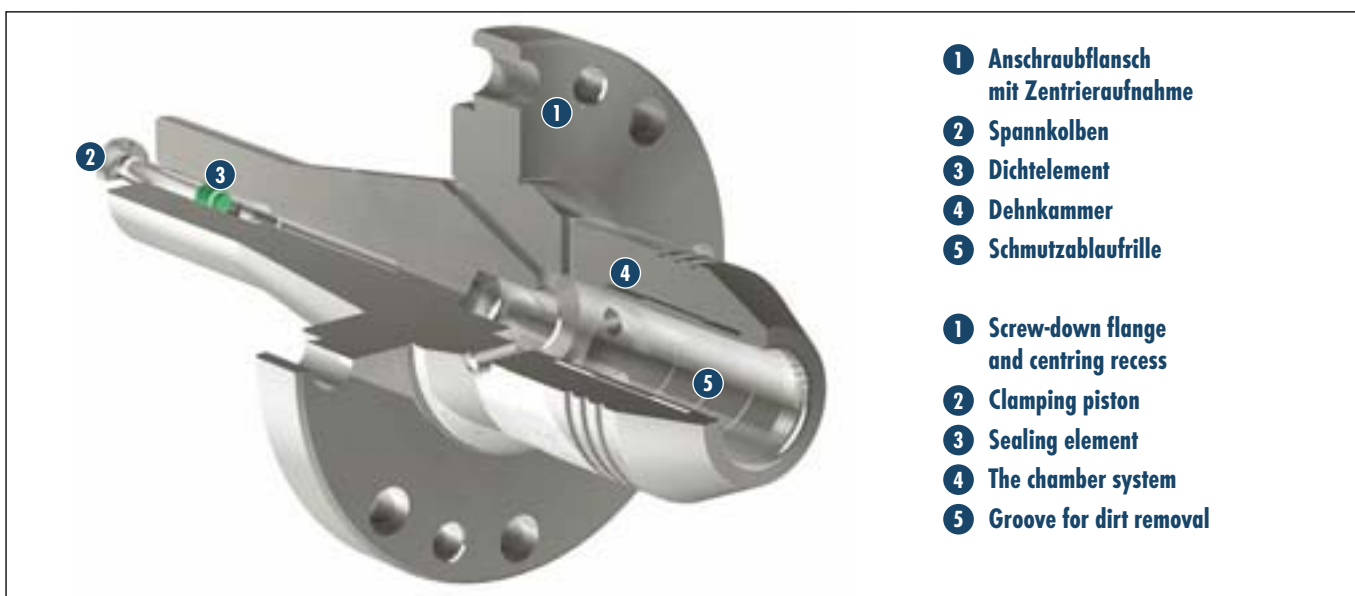

Spann-Ø D ₁ * Clamp. Ø D ₁ * [mm]	ID		D ₂ [mm]	D ₄ [mm]	X [mm]	L ₁ [mm]	L ₂ [mm]	L ₅ [mm]	L ₆ [mm]	L ₈ [mm]	G	m [kg]
12	0206645	○	36.5	21.5	9	59	50	5.5	31.5	33	M8 x 1	1.6
20	0206646	○	42	28	10	70	60	5.5	31.5	43	M12 x 1	1.8
22	0206647	○	44	30	7	77	70	5.5	35.5	46	M12 x 1	1.9
32	0206648	○	54	40	7	82	75	6	42.5	59	M12 x 1	2.1

* Für Werkzeugtoleranz h7 bei Ø 12 mm bis Ø 32 mm, andere Abmessungen auf Anfrage!

* Tool tolerance h7 for Ø 12 mm to Ø 32 mm, other dimensions on request!

Verfügbarkeit: ● lieferbar ab Lager ▲ kurzfristig lieferbar ○ auf Anfrage

Availability: ● available ex stock ▲ short lead time ○ on request